

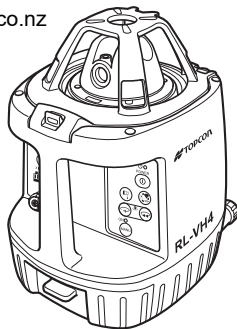

For more information contact Synergy Positioning Systems or  
visit the Synergy Positioning Systems website at [www.synergypositioning.co.nz](http://www.synergypositioning.co.nz)  
All branches: Phone 0800 867 266 Email: [info@synergypositioning.co.nz](mailto:info@synergypositioning.co.nz)



## INSTRUCTION MANUAL ROTATING LASER

---

# RL-VH4DR/G2

**EMC NOTICE**

In industrial locations or in proximity to industrial power installations, this instrument might be affected by electromagnetic noise. Under such conditions, please test the instrument performance before use.

***Declaration of Conformity***

R&TTE Directive 1995/5/EC

**WE:** TOPCON CORPORATION  
75-1 Hasunuma-cho Itabashi-ku Tokyo Japan

declare on our own responsibility, that the product;

**Kind of Product:** Rotating Laser, Remote controller

**Type designation:** RL-VH4DR/G2, RC-40

is in compliance with the following norm(s) or documents;

**EN 300 440-1, 2 EN 50371**

**EN 301 489-3**

**EN 60950-1**

**EU**

# Foreword

Thank you for purchasing the Topcon RL-VH4DR/G2 Rotating Laser.

It is one of the world's most advanced lasers.

To quickly and effectively use the RL-VH4DR/G2, please read these brief instructions carefully, and keep them in a convenient location for future reference.

## Handling Precautions

Before starting work or operation, be sure to check that the system is functioning properly.

### 1. Vibration and Impact Protection

When transporting the instrument, provide protection to minimize risk of severe vibration or impact. Severe vibration or impacts may affect beam accuracy.

### 2. Laser Scanning Interference

Particular reflective surfaces such as mirrors and some glass surfaces, can cause beam reflection that in very rare circumstances can interfere with the laser scanning function. If this should happen, simply change the location of the laser or cover the reflective surface.

### 3. Checking battery power.

Before operating, check remaining battery life.

### 4. Storing the instrument for long period

When storing the instrument for long period, remove the batteries.



### 5. Rotating Head

When sunlight, etc. enters the laser emitting window, laser beam output may temporarily decrease. In such a case, prevent sunlight, etc. from entering by using a parasol or other means.

## Safety Information

In order to encourage the safe use of products, to prevent damage to properties, and to prevent any danger to the operator and to others, important warnings are placed on the products and inserted in the instruction manuals.

We suggest that everyone understand the meaning of the following displays and icons before reading the “Safety Cautions” and text.

Display	Meaning
 <b>WARNING</b>	Ignoring or disregard of this display may lead to death or serious injury.
 <b>CAUTION</b>	Ignoring or disregard of this display may lead to personal injury or physical damage to the instrument.

- Injury refers to hurt, burn, electric shock, etc.
- Physical damage refers to damage to equipment and structure or furnishings.

## Safety Cautions



### WARNING

**There is a risk of fire, electric shock or physical harm if you attempt to disassemble or repair the instrument yourself.**

This is to be carried out by TOPCON or an authorized dealer, only!

**Laser beam can be dangerous, and can cause eye injury if used incorrectly.**

Never attempt to repair the instrument yourself.

**Cause eye injury or blindness.**

Do not stare into beam or view directly with optical instruments.

**Risk of fire or electric shock.**

Do not use a wet battery.

**May ignite explosively.**

Never use an instrument near flammable gas or liquid matter, and do not use in a coal mine.

**Battery can cause explosion or injury.**

Do not dispose in fire or heat.

**The short circuit of a battery can cause a fire.**

Do not short circuit battery when storing it.



## CAUTION

**Use of controls or adjustment or performance of procedures other than those specified herein may result in hazardous radiation exposure.**

**Let the laser beam reach the aimed object or the target without anybody else in the laser beam path. When operating in an open area, avoid radiating laser beam at eye level. It is quite possible for the beam to enter into one's eyes, and it is possible to lose visual sight temporarily, and lose one's caution and awareness of other dangers - avoid glaring beam.**

**Do not allow skin or clothing to come into contact with acid from the batteries, if this does occur then wash off with copious amounts of water and seek medical advice.**

**Risk of injury by dropping the instrument or case.**

Do not use a carrying case with damaged belts, grips or latches.

**It could be dangerous if the instrument falls over, please check that you fix the instrument to the wallmount or tripod.**

**Risk of injury by dropping a tripod and an instrument.**

Always check that the screws of tripod are tightened.

**Please note that the tips of tripod can be hazardous, be aware of this when setting up or carrying the tripod.**

## **User**

Wear the required protectors (safety shoes, helmet, etc.) when operating.

### **Exceptions from Responsibility**

- 1) The user of this product is expected to follow all operating instructions and make periodic checks of the product's performance.
- 2) The manufacturer, or its representatives, assumes no responsibility for results of a faulty or intentional usage or misuse including any direct, indirect, consequential damage, and loss of profits.
- 3) The manufacturer, or its representatives, assumes no responsibility for consequential damage, and loss of profits by any disaster, (an earthquake, a fire, an accident, storms, floods, an act of a third party and/or a usage other than under normal conditions.)
- 4) The manufacturer, or its representatives, assumes no responsibility for any damage, or loss of profits due to a change of data, loss of data, an interruption of business etc., caused by using the product or an unusable product.
- 5) The manufacturer, or its representatives, assumes no responsibility for any damage, or loss of profits caused by usage other than those usages explained in the user manual.
- 6) The manufacturer, or its representatives, assumes no responsibility for damage caused by wrong movement, or action due to connecting with other products.

## Laser Safety

This product projects a visible laser beam during operation. This product is manufactured and sold in accordance with “Performance Standards for Light-Emitting Products” (FDA/BRH 21 CFR 1040) or “Radiation Safety of Laser Products, Equipment Classification, Requirements and User’s Guide” (IEC Publication 60825-1) provided on the safety standards for laser beam.

As per the said standard, RL-VH4DR/G2 standard model is classified as “Class 3R (IIIa) Laser Products”. These are simple products to operate and do not require training from a laser safety officer. In case of any failure, do not disassemble the instrument. Contact TOPCON or your TOPCON dealer.

### Labels

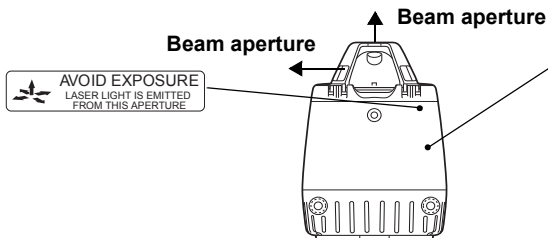

RL-VH4DR/G2 standard model





# Contents

Foreword .....	1
Handling Precautions .....	1
Safety Information .....	2
Safety Cautions .....	3
User .....	5
Exceptions from Responsibility .....	5
Laser Safety .....	6
Contents .....	7
Standard System Components .....	9
Nomenclature and Functions .....	10
Preparation for Use .....	12
Battery Installation .....	12
Instrument Set-up Procedure .....	12
Operation .....	14
Scanning Mode .....	14
Continuous scan .....	15
Plumb Beam Mode .....	16
Level Sensor Mode .....	17
Laser Pointing Mode (stop) .....	17
Changing rotation speed .....	17
How to Remove/Install Head Protector .....	18
Height Alert function .....	20
Setting Slopes .....	21
RC-40 Remote Controller .....	26

Nomenclature .....	26
Description of RC-40 functions .....	27
How to set remote controller communication channel .....	29
Maintaining Power Sources .....	30
Replacing dry batteries .....	30
Checking and Adjusting .....	31
Horizontal Calibration .....	32
Horizontal Rotation Cone Error.....	36
Vertical Calibration.....	37
Standard / Optional Accessories .....	41
Storage Precautions.....	47
How to Store .....	48
Specifications .....	49
Error Code.....	53

## Standard System Components

1	RL-VH4DR/G2 Instrument.....	1pc.
2	Remote Controller RC-40 .....	1pc.
3	Battery unit* <sup>1)</sup> .....	1set
4	AA size dry cell battery* <sup>2)</sup> .....	2pcs.
5	Carrying case .....	1pc.
6	Calibration decals .....	1set
7	Instruction manual .....	1vol.

- Please make sure that all of the above items are in the box when you unpack.
- Additional Magnetic Scanning Targets may be included in some markets.
- Optional Accessories (see page 41-page 46) may be included in some markets.

\*1) The following are battery configurations. Included battery configurations vary by package.

Rechargeable battery type: (with Built-in Run/Charge system) Rechargeable battery (BT-63Q)..... 1pc. Holder (DB-70C)..... 1pc. AC/DC converter (AD-13)..... 1pc.
--

Dry battery type: Holder (DB-70)..... 1pc. D size dry cell battery..... 4pcs.
---

\*2) Batteries included in the package are to confirm the initial operation.

Please replace the batteries provided with new batteries as soon as possible.

# Nomenclature and Functions

## RL-VH4DR/G2

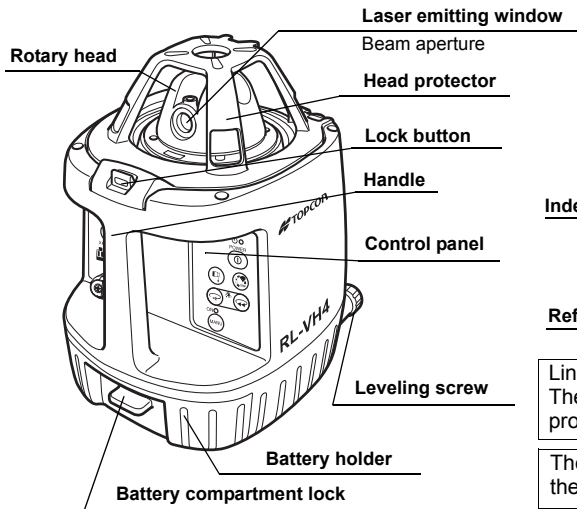

## Magnetic Scanning Target

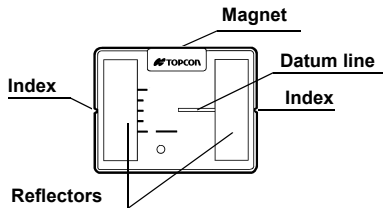

Lines may appear on the reflector strips. They are part of normal manufacturing process and do not effect performance.

The blue target is for RL-VH4G2 and the red target is for RL-VH4DR.

## Control Panel

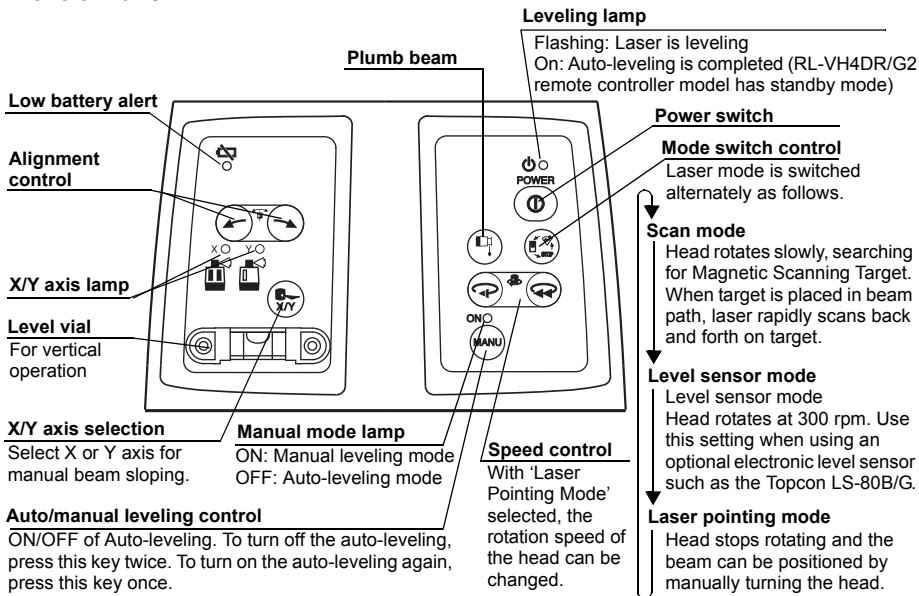

### (RL-VH4G2)

The laser output is not stable for several minutes when the power is on or the mode of laser is changed. After the beam is stabilized (display does not show WAIT), the mode can be changed.

# Preparation for Use

## Battery Installation

For battery placement or replacement instructions, see Maintaining Power Sources section, page 30.

## Instrument Set-up Procedure

### Horizontal Rotation

- 1 Set the instrument on any smooth surface that is within  $\pm 5^\circ$  of true level. The RL-VH4DR/G2 auto-level system will not function if the unit is placed more than  $5^\circ$  out of level. For best operation, it is recommended that it be mounted to a tripod or the Topcon Wall Mount Model 1D.

Slope can be set in both axes, X and Y. See “Setting Slopes” section, page 21.

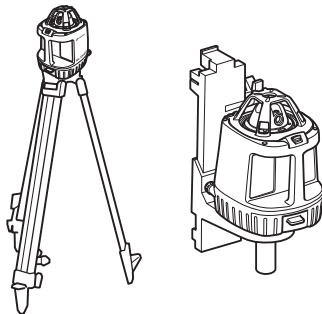
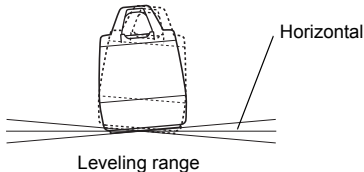

## Vertical Rotation

- 1 Place the instrument on its back as shown in the illustration.
- 2 Turn the leveling screw (s) underneath the instrument until the bubble in the level vial on the operational panel is centered.

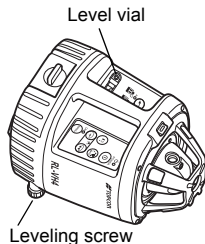

## Battery Warning Lamp

Flashing : The power is low

ON Solid : Dead batteries

Replace the batteries with new ones.

## Auto-leveling Lamp

Flashing : Auto-leveling is in process. When automatic leveling is almost complete, the flashing rate will be slow. The head will not rotate and the laser beam will not emit during the auto-leveling process.

ON Solid : Auto-leveling is complete.

The rotary head is active and emits the laser beam.

## Turning Auto-leveling Off

To turn OFF the auto-leveling function (manual mode), press the Auto/Manual control key twice in quick succession. The manual mode lamp will illuminate. The instrument can be positioned in any direction, the laser beam remains on and the head will rotate.

### IMPORTANT:

In manual mode, the laser beam will not shut off if disturbed! To return to Auto-leveling mode, press Auto/Manual control key once.

# Operation

## Scanning Mode

In scan mode, the laser rotates slowly, “searching” for the Magnetic Scanning Target. When the target is properly placed in the beam path, the laser beam will scan rapidly back and forth on the target and “track” the target as it is moved in its path.

- 1** To change to scanning mode when operating, press the mode switch control key (see page 11).
- 2** To initiate target scanning, place the Magnetic Scanning Target in the beam path with the reflective strips facing toward the laser.

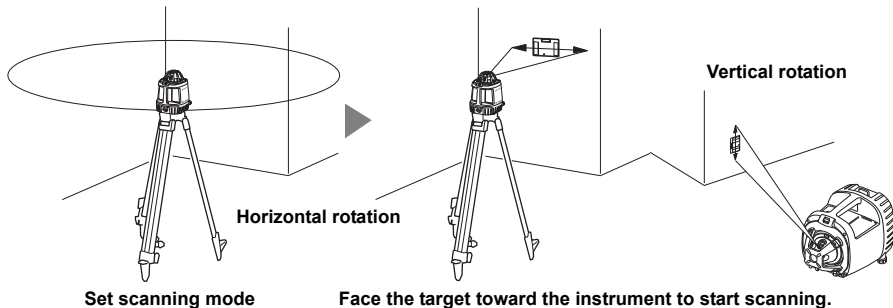

- 3** To end target scanning and resume searching beam, remove target from beam path.



## Continuous scan

(Scan line length can be “Drawn” and held for “Hands-free” operation)

Place target in beam path and hold for a moment. The scanning beam will hesitate, then start again. When the target is now removed the beam will continue to scan automatically.

To change the length of the scanning line, move the target left or right after the initial scan hesitation and the scanning line length will increase until the target is removed.

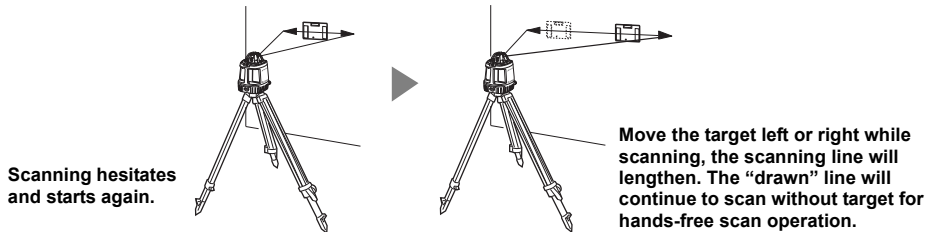

### To cancel the drawn scan mode:

In the drawn scan mode, release the target from the laser beam path for 2 seconds or longer and then place the target on the laser beam path once again.

## Plumb Beam Mode

You can set the instrument using with the plumb beam for centering.

To cancel the plumb beam mode, press any other key (except the plumb beam switch and the power switch).

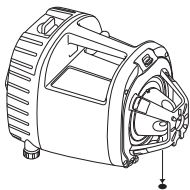

**Plumb beam for vertical operation**



This mode can be used with the Remote Controller RC-40.

## Level Sensor Mode

For long range or outdoor applications, the instrument can be used with an optional electronic level sensor. The Topcon LS-80G model is recommended. Press the mode switch control key to select level sensor mode. The beam rotates at 300 rpm in this setting.



- This mode can also be set with the Remote Controller RC-40.
- Use a level sensor best suited for the model.

RL-VH4DR : LS-80A / 80B / 90

RL-VH4G2 : LS-80G

## Laser Pointing Mode (stop)

This mode stops rotation and allows the laser beam to be pointed by manually rotating the head. Press the mode switch control key to select Laser pointing mode. Beam rotation stops in this mode.



The laser beam cannot be moved with the Remote Controller RC-40.

## Changing rotation speed

**(only available in Laser pointing mode)**

After selecting Laser pointing mode, press either Speed control key to change rotation speed. The right key increases the rotation speed. The left key reduces the rotation speed.



This mode can be used with the Remote Controller RC-40.

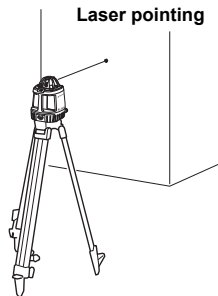

# How to Remove/Install Head Protector

When the head protector post blocks the laser beam and interferes with operation, remove the head protector from the instrument.

## How to Remove

- 1** Press the lock button to release the lock.
- 2** Set the angle of the head protector to approximately 45°.

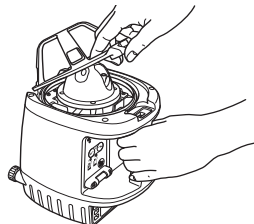
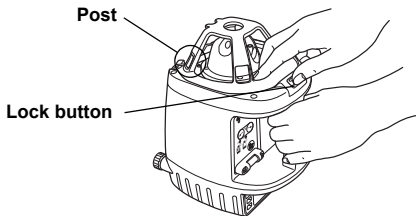

- 3** Pull the head protector in the direction of the arrow.

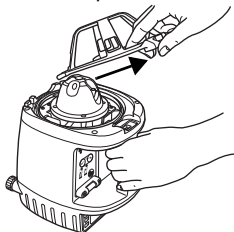

### NOTE

When the head protector is installed, do not hold by upper section of the head protector when transporting. Doing so may cause head protector to come off, with instrument falling off and may be damaged.

## How to Install

- 1** Insert the head protector pin into the groove of the instrument until you feel it click.

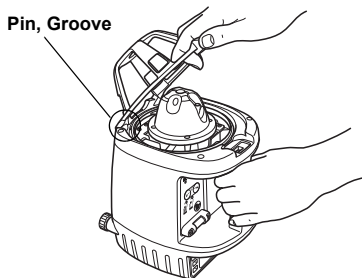

- 2** Bring down the head protector until you hear a clicking sound.

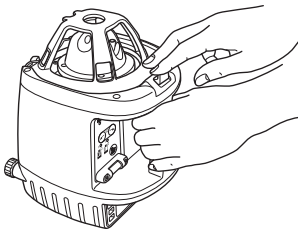

- 3** Check that the head protector is securely locked.

## Height Alert function

When auto-leveling and height alert function are active, this function prevents the instrument from operating if it is disturbed (after the laser beam emits for one minute). This helps insure accurate control. If the height or inclination of the instrument changes, the height of instrument should be verified and re-established if necessary.

**1** To activate the Height Alert function, depress and hold the left Alignment control key (see page 11) on the control panel while turning on the instrument by pressing the Power control key. The three LEDs (Leveling, Manual, Low battery alert) will flash at the same time for three seconds.

**2** When this function is active and the unit is disturbed, three visible LEDs will rapidly flash.

**3** To re-activate auto-leveling and check the beam height, turn the unit off, then on again by pressing the Power control key twice. After auto-leveling is complete, check the beam height to confirm it has not changed.

**4** The Height Alert function is now inactive. To re-activate, turn unit off and repeat step 1.

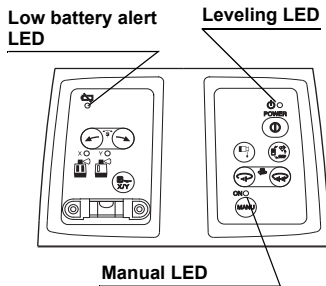

## Setting Slopes

The laser beam can be manually sloped in either the X or Y axis (single slope) or both axes (compound slope).

With the inclination of the instrument as the standard, laser beam can be sloped within the range of  $\pm 5^\circ$  up or down.



- The standard for the inclination is the inclination of the instrument, not that of the rotating head immediately after the auto-leveling.
- This mode can be used with the Remote Controller RC-40.

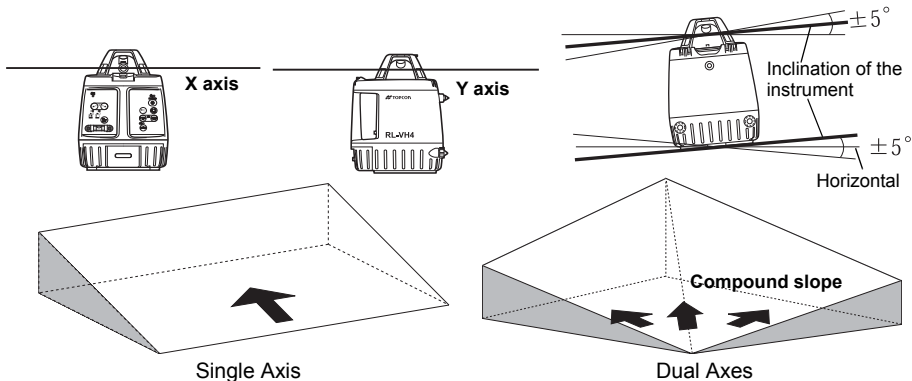

## How to set slope (Single Axis)

- 1** Turn the instrument on by pressing the Power control key. Auto-leveling will start.
- 2** Press the X/Y axis selection key once (see page 11). The X axis lamp will flash. To change to Y axis, press the X/Y key once again. Pressing the X/Y key toggles between X and Y axis selection.
- 3** Select the axis for which you would like to set the slope.
- 4** Press the mode switch control and set your desired rotation mode (scan mode / level sensor mode / laser pointing mode).
- 5** Press the alignment control key once. Laser beam will begin sloping to the direction of the key pressed in constant speed. Laser beam will begin sloping opposite to the direction that the key is pressed when the beam had sloped to its limit. Thereafter, the auto-leveling function will operate and return to the state described in procedure 3.
- 6** Press the Alignment Control key once more. Laser beam gradient will stop.
- 7** Adjust the gradient with the Alignment Control key. The speed of laser beam gradient will change according to the duration of time the Alignment Control key is being pressed. (The speed will change from low to high speed.) The Manual mode lamp will illuminate. The flashing lamp for the selected axis will change to solid after several seconds indicating that the slope has been entered in the direction of the selected axis.

Sample; Laser pointing mode

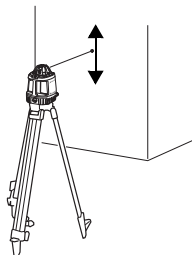

Move the beam up or down by pressing the right or left alignment keys



## How to set slope (Dual Axes)

After setting slope for one of the axis, select direction for the second axis by pressing the X/Y axis selection key, and set the slope following above-mentioned procedures 4 to 7.



After selecting the second axis and pressing the alignment control key once, if the key cannot be pressed for the second time, auto-leveling will be operated for the second axis only. In such a case, the first axis will be fixed at the set slope.



When the RC-40 is used in an environment where similar wireless transmission signals (such as wireless LAN) are emitted, the slope of the laser beam may temporarily stop when the alignment control key is long-pressed in the above procedure 7. If this interferes with the operation, change the transmission channels for the RL-VH4DR/G2 and the RC-40 (see page 29) and try again.

## Cancelling slope settings

Press the Auto/manual leveling control key. The instrument returns to auto-leveling mode.

## Line Control (manual vertical beam alignment)

- 1** Turn the leveling screw and position the bubble of the level vial on the control panel in the center.
- 2** Press the Power control key to turn unit on. When auto-leveling is complete, the laser beam will be emitted.
- 3** Press the plumb beam key to select the plumb beam mode.
- 4** Move the instrument to align Point A with the center of the laser. Press a key other than the plumb beam mode switch to release the plumb beam mode.
- 5** Press the mode switch control to set your desired rotation mode (scan mode / level sensor mode / laser pointing mode).
- 6** Press the alignment control key once. Laser beam will begin moving to the direction of the key pressed in constant speed. When coming to the limit of the movable range, it will move back to a position slightly before reaching the limit.
- 7** Press the Alignment Control key once more. Laser beam gradient will stop.
- 8** Press either one of the Alignment Control keys to move the beam right or left until it is precisely aligned to point B. The speed of laser beam movement will change according to the duration of time the Alignment Control key is being pressed. (The speed will change from low to high speed.)

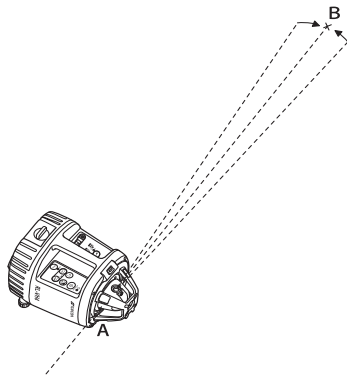



- This mode can be used with the Remote Controller RC-40.
- While an alignment control key is pressed the auto-leveling beam shut-off will not operate.
- To release the plumb beam mode for the RC-40, press either the mode switch control or speed control once.



When the RC-40 is used in an environment where similar wireless transmission signals (such as wireless LAN) are emitted, the slope of the laser beam may temporarily stop when the alignment control key is long-pressed in the above procedure 8. If this interferes with the operation, change the transmission channels for the RL-VH4DR/G2 and the RC-40 (see page 29) and try again.

# RC-40 Remote Controller

## Nomenclature

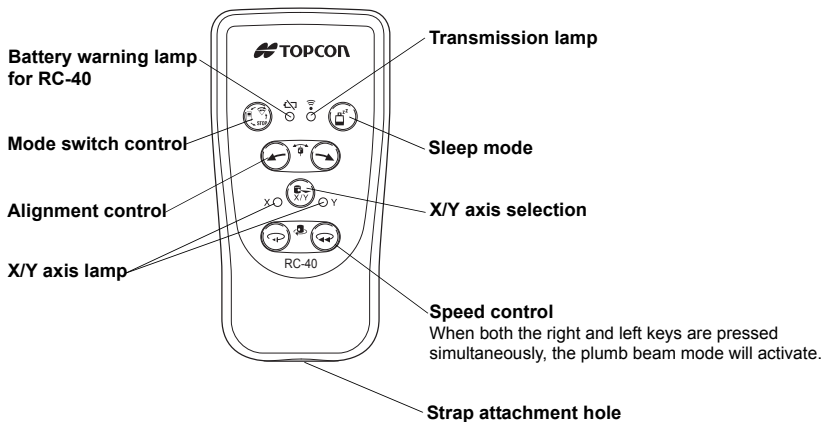

## Remote Controller

- The Remote Controller RC-40 cannot be used to operate the Rotating Laser RL-VH3 series or RL-VH4G.
- The Remote Controller RC-30 cannot be used to operate the Rotating Laser RL-VH4DR or RL-VH4G2.

## Description of RC-40 functions

<p><b>Sleep mode</b></p>	<p>To set up (or cancel) the rotating laser to the sleep mode, press the sleep mode key for three seconds or longer. (In Sleep mode, the leveling lamp of the rotating laser will flash.) Laser turns off if standby mode continues for two hours. (This mode cannot be used when the main power of the rotating laser is OFF.)</p>
<p><b>Transmission lamp</b></p>	<p>This lamp will flash green when the signal is being transmitted. The lamp will flash red when an internal error has occurred during transmission.</p>
<p><b>Battery warning lamp for RC-40</b></p>	<p>Battery warning for RC-40. Replace the batteries with new ones.</p>
<p><b>Speed control</b></p>	<p>The rotation speed of the rotary head can be changed. Pressing the left key will slow and pressing the right key will accelerate the rotation speed. When both the right and left keys are pressed simultaneously, the plumb beam mode will activate.</p>
<p><b>Alignment control</b></p> <p><b>Vertical : Setting line control</b></p> <p><b>Horizontal : Setting slope</b></p>	<p>Performs line control during vertical rotation. (Valid when the x or y axis is being selected with the x/y axis selection key.)</p> <p>Sets slope to the slope setting direction during horizontal rotation. (Valid when the x or y axis is being selected with the x/y axis selection key.)</p>
<p><b>X/Y axis lamp</b></p>	<p>Indicates axis selected during beam sloping operation.</p>

<b>Mode switch control</b>	<p>Laser mode is switched alternately as follows.  Scan mode / Level sensor mode / Laser pointing mode.  If this key is pressed in other modes except Scan, Laser sensor and Laser pointing modes, the mode will change to scan mode.</p>
<b>X/Y axis selection</b>  <b>Vertical : Setting line control</b>  <b>Horizontal : Setting slope</b>	<p>Sets line control mode by pressing the key for more than three seconds. Then X axis lamp will light.</p> <p>Sets slope mode by pressing the key for more than three seconds. Then X axis lamp will light. Lightly pressing this key for short time will switchover the X and Y axis.</p> <p>Press the alignment key when in the above rotation (vertical, horizontal), only then will the rotating laser switch to the line control mode or the slope mode.</p> <p>To cancel the line control mode or the slope mode, press this key for more than three seconds.</p> <p>When this key is pressed under the interference condition (several RC-40s or RL-VH4DR/G2 are using the same channel), the X/Y axis red lamp will flash.</p> <p>The X/Y axis red lamp will also blink simultaneously when set up on a different channel or when RL-VH4DR/G2 power is not on.</p>



When you find it difficult to operate the remote controller, use it away from the ground.  
(Radio transmission performance is lower near the ground.)



With the RC-40, both the X and Y axes lamps will flash red simultaneously when more than one RC-40 or RL-VH4DR/G2 are used, and also when similar wireless signals (wireless LAN, etc.) are being transmitted.

## How to set remote controller communication channel

The same channel (1 to 9) must be set on the RL-VH4DR/G2 and the RC-40 remote controller.

### RL-VH4DR/G2

- 1 Remove the battery cover by turning the battery compartment lock to "OPEN".
- 2 Turn the channel switch to set a channel by using a small straight screwdriver (see illustration for switch location).
- 3 Replace the battery cover and turn the knob to "Lock".

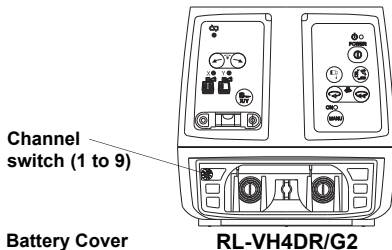

### RC-40

- 1 Open the battery cover and remove the batteries.
- 2 Turn the channel switch to the same channel position set on the RL-VH4DR/G2. (Initial setting at shipping : Channel 1)
- 3 Insert batteries and close the battery cover.

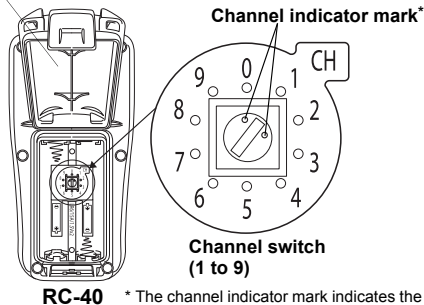

\* The channel indicator mark indicates the direction of the selected channel. In the above figure, channel 1 is selected.

# Maintaining Power Sources

## Replacing dry batteries

- 1** Remove the battery cover by turning the battery compartment lock to “OPEN”.
- 2** Remove the old batteries and replace with new 4×D size dry cell batteries (alkaline) making sure each is placed in the proper direction as indicated.
- 3** Replace the battery cover and turn the knob to “Lock”.

<b>NOTE</b>	<ul style="list-style-type: none"><li>• Replace all 4 batteries with new ones.</li><li>• Do not mix old batteries and new ones.</li></ul>
-------------	---

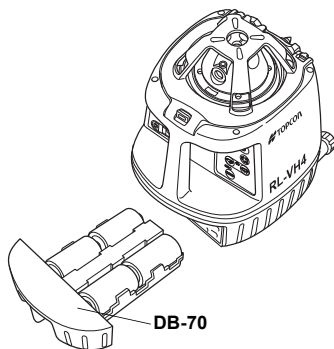



# Checking and Adjusting

There are three areas of performance the user should check periodically.

Horizontal Calibration

Horizontal Rotation Cone

Vertical Calibration

The Horizontal Calibration and Vertical Calibration can be easily checked and, in most cases, adjustments can be made by the user. Horizontal Rotation Cone can be checked by the user, but if an error is found, adjustments must be made by a Topcon service facility.

## Attaching the calibration decals

Before calibration, attach the calibration decals to the instrument as shown below. The calibration decal shows the calibration function of certain control keys on the control panel.

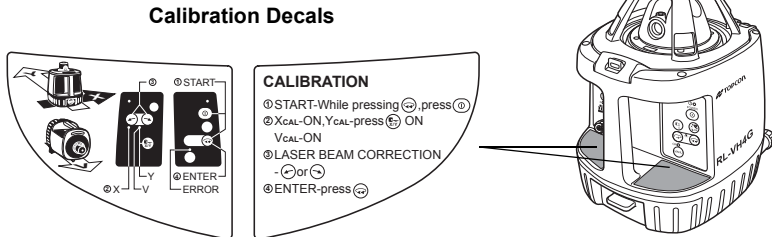

## Horizontal Calibration

### (1) Checking Calibration

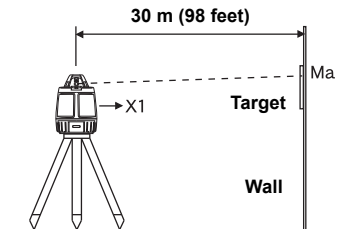

Instrument as seen from above

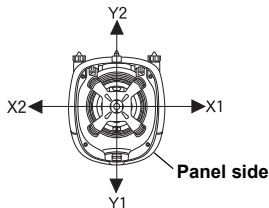

- 1** Set up a tripod 30 m (98 ft) from a wall. Mount the instrument on the tripod, facing the X1 side toward the wall.
- 2** Turn the unit on and allow auto-leveling to complete.
- 3** Place a piece of paper on the wall. Detect the laser position on the wall with target and mark it. Turn the instrument off.
- 4** Loosen the tripod screw, rotate the instrument 180 degrees.

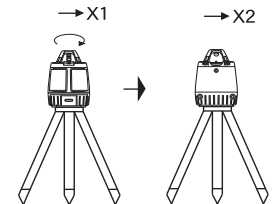

#### NOTE

When rotating the instrument, make sure the heights of the instruments are aligned.



When the laser beam is difficult to see, it can be checked in the Level sensor mode or the Laser pointing mode.

- 5** Turn the unit on again and allow auto-leveling to complete.
- 6** Make a new mark (Mb) where the laser beam strikes the paper.
- 7** Measure the distance between the first mark (Ma) and the second mark (Mb). No calibration is necessary if distance is within 6 mm (1/4 of an inch).
- 8** Repeat procedure for the Y axis.

If less than 6 mm (.23 inches)  
No calibration Necessary

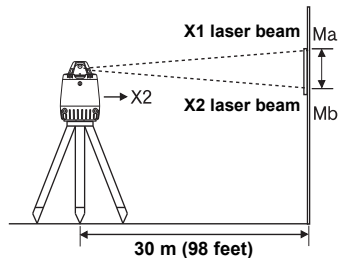

## (2) Adjusting Calibration

If the distance between either set of marks is more than 6 mm (1/4 of an inch) but less than 25 mm (1 inch), turn the unit off by pressing the [START] key once and use the following procedure to calibrate the laser. Confirm that unit has shut off before beginning the procedure. (In steps 2 and 3, use of optional RC-40 remote controller can be helpful. See page 36.)

- 1 While pressing the [ENTER] key, press the [START] key. This activates the X axis calibration mode. Confirm that the Leveling lamp, Manual mode lamp and [X] axis lamp are lit.

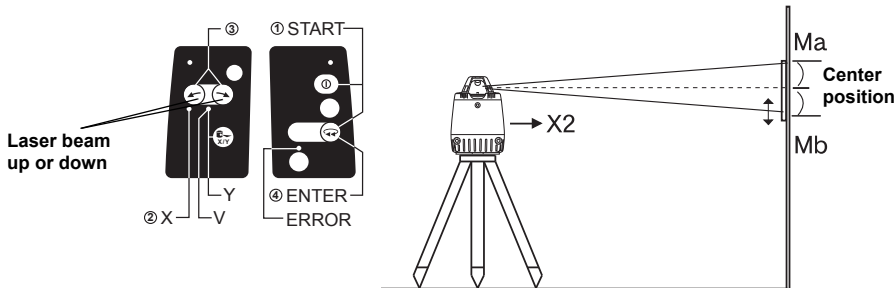

- 2 By pressing the right or left Alignment Control key, move the X2 (Mb) laser beam up or down until its centered between marks Ma and Mb.

### NOTE

- This operation can be performed with the Remote Controller RC-40.
- When using the RC-40, select the X axis with the X/Y axis selection key and move the laser beam up or down with the alignment key.

**3** When the beam is precisely centered, press the [ENTER] key.



This operation can be performed with the Remote Controller RC-40. When using the RC-40, press the [ENTER] key on the RC-40 unit. (The [ENTER] key for the RC-40: The same mark as the [ENTER] key for the instrument.)

The [X] axis lamp will flash.

When the flashing stops, the X axis calibration adjustment is made and power is turned off.

**4** For Y axis calibration, turn the unit as instructed in step 1 then press the X/Y Axis Selection key.



This operation can be performed with the Remote Controller RC-40. When using the RC-40, select the Y axis using the X/Y axis selection key and move the laser beam up and down with the Alignment control key.

Confirm that the [Y] axis lamp is lit, then repeat steps 2 to 4 for the Y axis.

Repeat the checking procedure to confirm proper calibration has been made.

**NOTE**

If the calibration is greater than the adjustment allows, the error lamp will start flashing. (See "Error Code" on page 53)  
If this occurs, contact your Topcon dealer.



When the laser beam is difficult to see, it can be adjusted in the Laser sensor mode or the Laser pointing mode.

## Horizontal Rotation Cone Error

Perform the following check after completing “Horizontal Calibration” on the previous page.

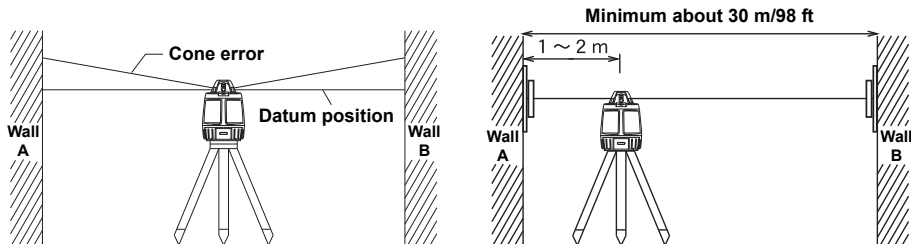

- 1** Set up the laser centered between two walls approximately 30 m (98 ft) apart. Orient the instrument so one axis, either X or Y, is facing the walls.
- 2** Locate and mark the position of the rotating laser beam on both walls using the target.
- 3** Turn off the instrument and move the instrument closer to wall A (1 m to 2 m / 3 ft to 6 ft). Do not change the axis orientation of the instrument. Turn the instrument on.
- 4** Again locate and mark the position of the rotating laser beam on both walls.
- 5** Measure the distance between the first and second marks on each wall.
- 6** If the difference between each set of marks is less than 3 mm (1/8 of an inch), no error exists.

<b>NOTE</b>	If the error is greater than 3 mm (1/8 of an inch), contact your Topcon dealer.
-------------	---

## Vertical Calibration

Perform the following check after completing “Horizontal Calibration” on the previous page.

### (1) Checking

- 1 Set up the instrument half way between two walls a minimum of 30 m (98 ft) apart. (The instrument can be facing either direction X or Y. No tripod is used.)
- 2 Turn the power switch on.
- 3 Place a piece of paper on each wall (A and B). Mark the horizontal laser positions (Ma and Mb) on each wall using target.
- 4 Turn the power switch off. Position the instrument for vertical operation (see instruction on page 13) with the rotary head directly facing wall A (see illustration). Make sure the unit is level by checking the level vial. Use the leveling screw to adjust if necessary.
- 5 Turn the power switch on. (Laser beam should be in scanning mode.)
- 6 Mark where the split beam emitted from the top of the rotary head strikes wall A (Ha). Measure the distance (dHa) between marks Ma and Ha.

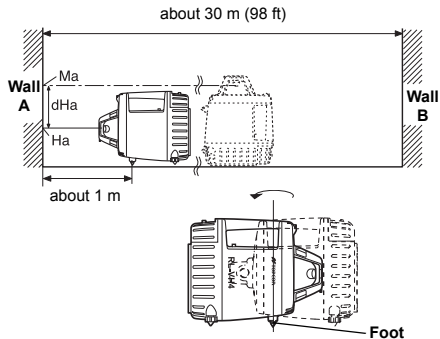
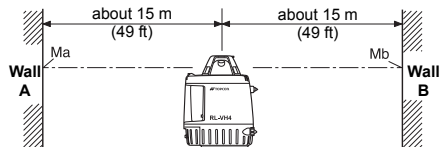

**7** Without moving the position of the front foot, pivot the instrument so the rotary head is now facing wall B.

**8** Mark where the split beam emitted from the top of the rotary head strikes wall B (Hb). Measure the distance (dHb) between marks Mb and Hb.

**9** Compare the two measurements dHa and dHb. If the difference between the two measurements is less than 3 mm (1/8 of an inch), no adjustment is necessary. Otherwise, adjust as follows.

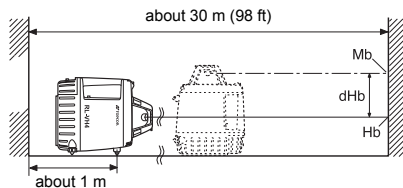



## (2) Adjusting Calibration

Turn the unit off by pressing the [START] key once. Confirm that unit has shut off before beginning the following procedure. (In step 2 and 3, optional RC-40 remote controller is helpful.)

- 1 Without moving the unit, press the [ENTER] and [START] keys simultaneously.
- 2 Press either the right or left key on the Alignment Control key to move the laser beam up or down on wall B until the measurement for the distance  $dHb$  is the same as the measurement  $dHa$  on wall A.



This operation can be performed with the Remote Controller RC-40. When using the RC-40, select the Y axis using the X/Y axis selection key and move the laser beam up and down with the Alignment control key.

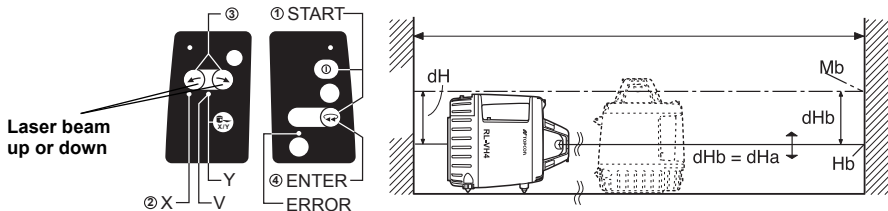

- 3** When the beam is positioned so the two measurements are the same, press the [ENTER] key. The [V] axis lamp will flash.  
When the flashing stops, the vertical calibration adjustment is made and power is turned off.



This operation can be performed with the remote controller RC-40.  
When using the RC-40, press the [ENTER] key on the RC-40 unit.  
(The [ENTER] key for the RC-40: The same mark as the [ENTER] key for the instrument.)

**NOTE**

If the calibration is greater than the adjustment allows, the error lamp will start flashing. If this occurs, contact your Topcon dealer.

Repeat the checking procedure to confirm proper calibration has been made.

# Standard / Optional Accessories

## LS-80A / 80B / 80G / 90 Level Sensor

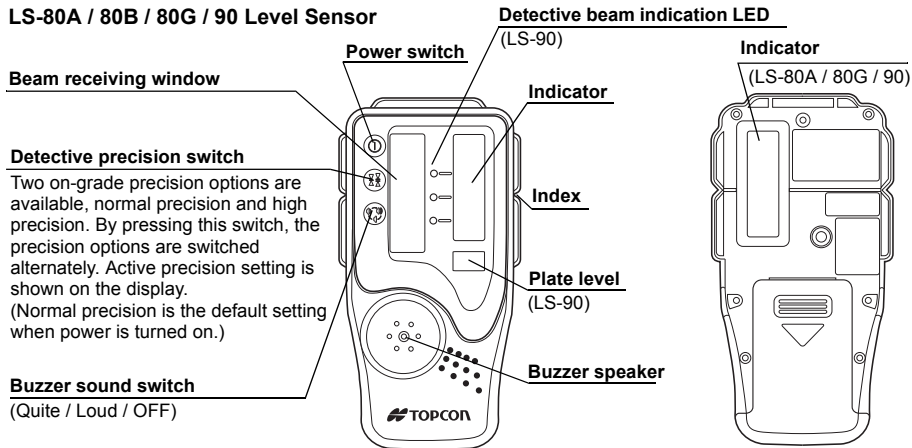

### Auto-cut off function

The power will be turned off automatically if no laser beam is detected within approximately 30 minutes.  
(To turn the level sensor on again, press the power switch.)

When using the RL-VH4DR/G2, there is no height alert warning of rotating laser or the rotating laser battery warning.

Applicable model RL-VH4DR : LS-80A / 80B / 90  
RL-VH4G2 : LS-80G

## Display

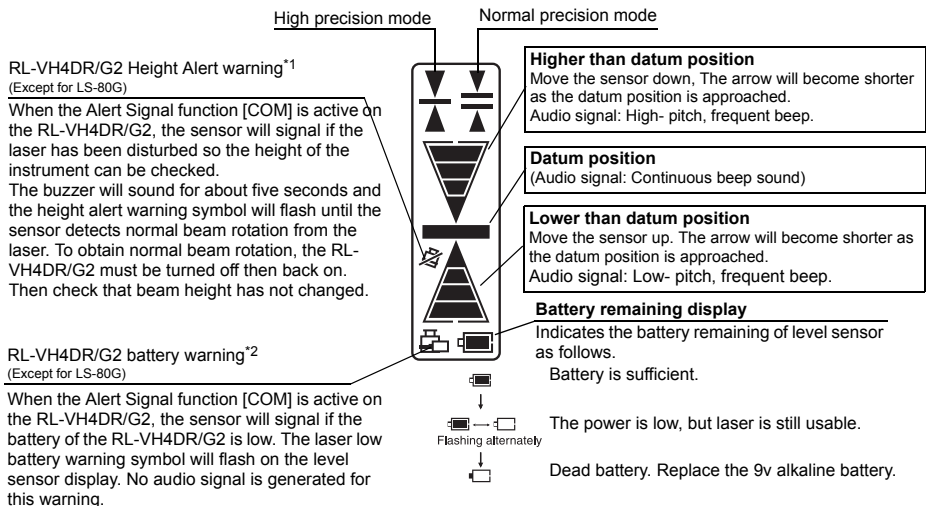

The warning signal \*1 and \*2 will function only if RL-VH4DR/G2 Alert Signal function [COM] is active.

Alarm detection at the level sensor can be canceled by turning off the level sensor switch while pressing the buzzer sound switch. When the switch is turned back on again, alarm detection functions as usual.

## Detective range (LS-80A / 80B / 80G)

Display	Precision	
	80A/80G	80B
	 High $\pm 1\text{mm}$ (2mm width)	
	 Normal $\pm 2\text{mm}$ (4mm width)	
	$\pm 5\text{mm}$ (10mm width)	—
	$\pm 10\text{mm}$ (20mm width)	—
	$\pm 15\text{mm}$ (30mm width)	—
	more than $\pm 15\text{mm}$ (more than 30mm width)	more than $\pm 5\text{mm}$ (more than 10mm width)
	Level sensor is moved upward or downward from laser beam. (*LS-80B : Blinking)	

## (LS-90)

Display	Precision (LED display)
	 $\pm 0.5\text{mm}$ (1mm width)
	 $\pm 2\text{mm}$ (4mm width)
	LED : Lights in the center
	$\pm 5\text{mm}$ (10mm width) LED : Flashes alternately
	$\pm 10\text{mm}$ (20mm width) LED : Flashes rapidly
	$\pm 15\text{mm}$ (30mm width) LED : Flashes
	more than $\pm 15\text{mm}$ (more than 30mm width) LED : Flashes slowly
	When the laser beam is off to the top or to the bottom LED : Flashes rapidly

## Replacing Battery

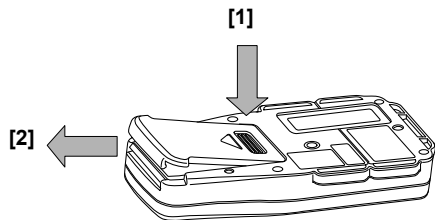

- 1** Keep pushing the battery cover in 1 direction, and then try to slide the cover in 2 direction. The cover does not move but it will be open.
- 2** Take out the battery and place a new one into the battery box.
- 3** Press the lid down and click to close.

## Level sensor holder model 6

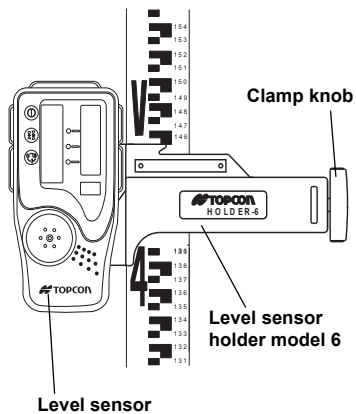

## Wall Mount 1D

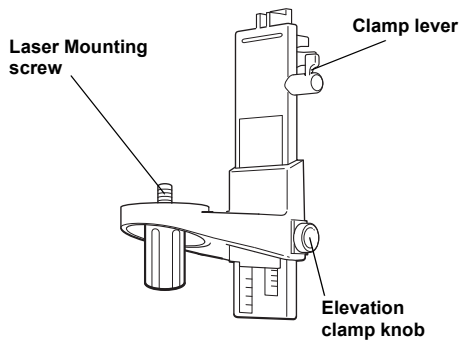

**Battery holder DB-70C**  
**Rechargeable battery pack BT-63Q**  
**AC/DC converter AD-13**  
**For Charging**

- 1** Plug the AC/DC converter (AD-13) into the DB-70C battery holder.
- 2** Insert the converter power cord in an outlet.
- 3** Complete charging by unplugging the converter connector from the DB-70C battery holder after approximately 9 hours.
- 4** Unplug the converter power cord from the outlet.

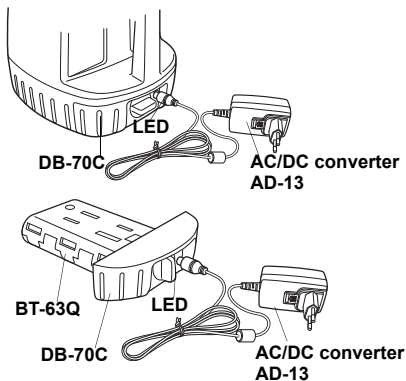

**The LED of DB-70C will indicate charging status;**

- Red ON: Charging.
- Green ON: Charging completed.
- Green flashing: DB-70C is not connected to BT-63Q.
- Red flashing: BT-63Q protection feature is working automatically.  
RL-VH4DR/G2 can be used in this state.

**Automatic protection feature; In case of overcharge or high or low temperature state exceeding charging range, charging will be stopped or changed to protect battery.**



DB-70C can be used with dry batteries instead of BT-63Q.





- 1) The Ni-MH BT-63Q rechargeable battery can be charged while using the laser.
- 2) The DB-70 dry cell battery holder cannot be used to charge the BT-63Q Ni-MH battery pack. Use the DB-70C charging battery holder instead.

## Storage Precautions

Always clean the instrument after use.

Use a clean cloth, moistened with a neutral detergent or water. Never use an abrasive cleaner, ether, thinner benzene, or other solvents.

Always make sure instrument is completely dry before storing. Dry any moisture with a soft, clean cloth.

# How to Store

LS-80A / 80B / 80G / 90

RL-VH4DR/G2

D size dry cell battery

RC-40

AD-13

Level sensor  
holder model 6

Wall Mount 1D

AA size dry cell battery

Magnetic Target

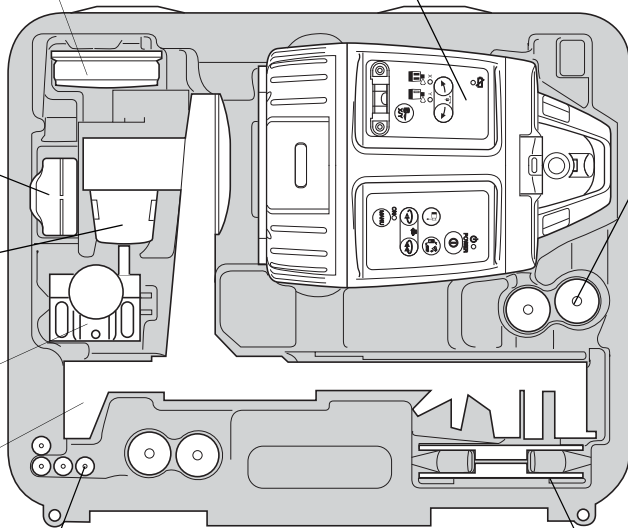

# Specifications

## RL-VH4DR/G2

### Accuracy

Horizontal :  $\pm 20''$

Vertical :  $\pm 20''$

### Auto-leveling range

:  $\pm 5^\circ$

### Measuring range (Diameter)

: RL-VH4DR : Using with LS-80A / 80B / 90 : 2 m (6.6 ft) to 300 m (984 ft)

(Rotation speeds 300 r.p.m)

RL-VH4G2 : Using with LS-80G : 2 m (6.6 ft) to 300 m (984 ft)

### Rotation speeds

: Changeable (0 to 300 r.p.m)

### Scanning range (Diameter)

: 2 m (6.6 ft) to 60 m (197 ft)

### Scanning width

: Maximum  $180^\circ$

### Light source

: RL-VH4DR Diode red laser (635nm)

RL-VH4G2 Diode-pumped Solid-state green laser (532nm)

### Power supply

: 4xD size dry cell batteries (DC6V)

Ni-MH battery pack BT-63Q (It can be charged while using it.)

### Continuous operating time

at  $+20^\circ\text{C}$  ( $+68^\circ\text{F}$ )

: RL-VH4DR 4xD size dry cell batteries (alkaline)90h

Ni-MH battery pack BT-63Q 65h

RL-VH4G2 4xD size dry cell batteries (alkaline)30h

Ni-MH battery pack BT-63Q 24h

### Tripod screw

: Flat and dome head type, W 5"/8 x 11 threads

### Operating temperature

:  $-20^\circ\text{C}$  to  $+50^\circ\text{C}$  ( $-4^\circ\text{F}$  to  $+122^\circ\text{F}$ )

### Protection against

: IP54 (Category 2)

### water and dust

### Dimensions

: 182 (L)  $\times$  167 (W)  $\times$  241.5 (H) mm [7.2 (L)  $\times$  6.6 (W)  $\times$  9.5 (H) in]

### Weight

: RL-VH4DR 2.2 kg [4.9 lbs] (without dry batteries)

RL-VH4G2 2.6 kg [5.7 lbs] (without dry batteries)

## Remote controller RC-40

### Operating range (Radius)

: 100m or more (Condition: set the RL-VH4DR/G2 on a tripod. Use the RC-40 at 1.2 meters above ground.)

: 30m or more (Condition: set the RL-VH4DR/G2 on ground with vertical operation. Use the RC-40 at 30cm above ground.)

### Power supply

: 2×AA size dry cell batteries (alkaline)

### Operating time

: Approx. 5 months (depends on the nature of use)

### Protection against

: IP66 (Based on the standard IEC 60529)

### Dimensions

: 116 (L) × 59 (W) × 31.4 (H) mm [4.6 (L) × 2.3 (W) × 1.2 (H) in]

### Weight

: 150 g [0.33 lbs] (including dry batteries)

**LS-80A / 80G (Back side display area)****Detective range** : 50 mm (2.0 in)**Detective precision**High precision :  $\pm 1$  mm ( $\pm 0.04$  in)Normal precision :  $\pm 2$  mm ( $\pm 0.08$  in)**Detective beam indication**: Liquid crystal (Both sides) and  
buzzer**Power source** : 2×AA size dry cell batteries**Power voltage** : 3VDC**Continuous operating time**

Alkaline manganese dry battery

: Approx. 120 hours

**The time for auto-cut off**

: Approx. 30 min.

**Waterproof property / Dust resistance**

: JIS protection grade IP66

**Operating temperature**:  $-20$  °C to  $+50$  °C ( $-4$  °F to  $+122$  °F)**Dimensions** : 146 (l) × 76 (w) × 26 (h) mm

(5.7 (l) × 2.9 (w) × 1.0 (h) in)

**Weight** : 0.19 kg (0.41 lbs)

(Including dry batteries)

**LS-80B****Detective range** : 50 mm (2.0 in)**Detective precision**High precision :  $\pm 1$  mm ( $\pm 0.04$  in)Normal precision :  $\pm 2$  mm ( $\pm 0.08$  in)**Detective beam indication**

: Liquid crystal and buzzer

**Power source** : 2×AA size dry cell batteries**Power voltage** : 3VDC**Continuous operating time**

Alkaline manganese dry battery

: Approx. 120 hours

**The time for auto-cut off**

: Approx. 30 min.

**Waterproof property / Dust resistance**

: JIS protection grade IP66

**Operating temperature**:  $-20$  °C to  $+50$  °C ( $-4$  °F to  $+122$  °F)**Dimensions** : 146 (l) × 76 (w) × 26 (h) mm

(5.7 (l) × 2.9 (w) × 1.0 (h) in)

**Weight** : 0.19 kg (0.41 lbs)

(Including dry batteries)

**LS-90 (Back side display area / LED / Plate level)****Detective range** : 50 mm (2.0 in)**Detective precision**High precision :  $\pm 0.5$  mm ( $\pm 0.02$  in)Normal precision :  $\pm 2$  mm ( $\pm 0.08$  in)**Detective beam indication**

: Liquid crystal (Both sides) / Buzzer / LED

**Power source** : 2×AA size dry cell batteries**Power voltage** : 3VDC**Continuous operating time**

Alkaline manganese dry battery

: Approx. 100 hours

**The time for auto-cut off**

: Approx. 30 min.

**Waterproof property / Dust resistance**

: JIS protection grade IP66

**Operating temperature**:  $-20$  °C to  $+50$  °C ( $-4$  °F to  $+122$  °F)**Dimensions** : 146 (l) × 76 (w) × 26 (h) mm

(5.7 (l) × 2.9 (w) × 1.0 (h) in)

**Weight** : 0.19 kg (0.41 lbs)

(Including dry batteries)

## Error Code

Use the table below to determine operation errors indicated by blinking lamps on the control panel. If corrective action listed does not correct error, please contact your local Topcon dealer.

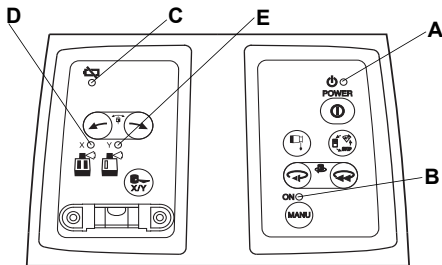

Lamp Indication	Error Code	Cause	Corrective Action
Lamp A, B and C blink in turn	Auto-leveling range error	Instrument tilt 5 degrees or more	Correct tilt of the instrument until it less than 5 degrees.
Lamp C lights	Battery power out error	Batteries depleted.	Replace all 4 batteries with new ones at the same time.
Lamp A, B and C blink simultaneously	Height alert error	Sharp change in the installation state	Turn power off, rough level the instrument, then turn power on again. Check height of laser beam as it may have changed.
Lamp B blinks	Calibration error	Exceeding the range of calibration	Repeat calibration procedure. If error repeats contact your local Topcon dealer.

<b>Lamp Indication</b>	<b>Error Code</b>	<b>Cause</b>	<b>Corrective Action</b>
Lamp D and E blink simultaneously	Internal error	Internal error	Turn power off, then on again. If error repeats contact your local Topcon dealer.



Use the table below to determine operation errors indicated by blinking lamps on the RC-40 control panel.

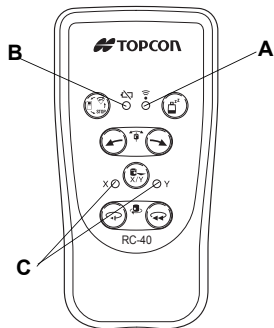

Lamp Indication	Error Code	Cause	Corrective Action
Lamp A red blinks	Internal error	Internal error	Remove and reinsert batteries once again. If error repeats contact your local Topcon dealer.
Lamp B blinks	Battery power out error	Batteries depleted	Replace all 2 batteries with new ones at the same time.
Lamp C blinks simultaneously	Communication error	Error in channel setting Power not turned on Channel interference	Change the channel. Turn on the power for RL-VH4DR/G2. If the error persists, check the transmission environment and reduce wireless LAN and other similar wireless transmissions as much as possible.

©2008 TOPCON CORPORATION  
ALL RIGHTS RESERVED



---

## **TOPCON POSITIONING SYSTEMS, INC.**

7400 National Drive, Livermore, CA 94551, U.S.A.  
Phone: 925-245-8300 Fax: 925-245-8599 [www.Topconpositioning.com](http://www.Topconpositioning.com)

### **TOPCON CALIFORNIA**

3380 Industrial Blvd, Suite 105, West Sacramento, CA 95691, U.S.A.  
Phone: 916-374-8575 Fax: 916-374-8329

## **TOPCON EUROPE POSITIONING B.V.**

Essebaan 11, 2908 LJ Capelle a/d IJssel, The Netherlands.  
Phone: 010-458-5077 Fax: 010-284-4941 [www.topconeurope.com](http://www.topconeurope.com)

### **IRELAND OFFICE**

Unit 69 Western Parkway Business Center  
Lower Ballymount Road, Dublin 12, Ireland  
Phone: 01460-0021 Fax: 01460-0129

## **TOPCON DEUTSCHLAND G.m.b.H.**

Giesslerallee 31, 47877 Willich, GERMANY  
Phone: 02154-885-100 Fax: 02154-885-111 [info@topcon.de](mailto:info@topcon.de)  
[www.topcon.de](http://www.topcon.de)

## **TOPCON S.A.R.L.**

89, Rue de Paris, 92585 Clichy, Cedex, France.  
Phone: 33-1-41069490 Fax: 33-1-47390251 [topcon@topcon.fr](mailto:topcon@topcon.fr)

## **TOPCON SCANDINAVIA A. B.**

Neogatan 2 S-43151 Mölndal, SWEDEN  
Phone: 031-7109200 Fax: 031-7109249

## **TOPCON (GREAT BRITAIN)LTD.**

Topcon House Kennet Side, Bone Lane, Newbury, Berkshire RG14 5PX U.K.  
Phone: 44-1635-551120 Fax: 44-1635-551170  
[survey.sales@topcon.co.uk](mailto:survey.sales@topcon.co.uk) [laser.sales@topcon.co.uk](mailto:laser.sales@topcon.co.uk)

## **TOPCON SOUTH ASIA PTE. LTD.**

Blk 192 Pandan Loop, #07-01 Pantech Industrial Complex, Singapore 128381  
Phone: 65-6778-3456 Fax: 65-6773-6550 [www.topcon.com.sg](http://www.topcon.com.sg)

## **TOPCON INSTRUMENTS (THAILAND) CO., LTD.**

77/162 Sinn Sathorn Tower, 37th Fl.,  
Krungdhonburi Rd., Klongtong Sai, Klongsarn, Bangkok 10600 Thailand.  
Phone: 66-2-4401152~7 Fax: 66-2-4401158

## **TOPCON INSTRUMENTS (MALAYSIA) SDN. BHD.**

No.D1, (Ground, Lower Ground & 1st Floor), Jalan Excella 2, Off Jalan Ampang  
Putra, Taman Ampang Hilir, 55100 Kuala Lumpur, Malaysia  
Phone: 60-3-42709866 Fax: 60-3-42709766

## **TOPCON CORPORATION BEIJING OFFICE**

Block No.9, Kangding Street  
Beijing Economic-Technological Development Area, Beijing, 100176, China  
Phone: 86-10-6780-2799 Fax: 86-10-6780-2790

## **TOPCON CORPORATION DUBAI OFFICE**

P. O Box293705, Office C-25(row C-2), Dubai Airport Free Zone, Dubai, UAE  
Phone: 971-4-2995900 Fax: 971-4-2995901 [marketing@Topcon.ae](mailto:marketing@Topcon.ae)

---

# **TOPCON CORPORATION**

75-1 Hasunuma-cho, Itabashi-ku, Tokyo 174-8580, Japan  
[www.topcon.co.jp](http://www.topcon.co.jp)