

3DMC[®]



Reference Guide



3D-MC Reference Guide

Part Number 7010-0911

Rev. E

**©Copyright Topcon Positioning Systems
October, 2013**

All contents in this manual are copyrighted by Topcon. All rights reserved. The information contained herein may not be used, accessed, copied, stored, displayed, sold, modified, published, or distributed, or otherwise reproduced without express written consent from Topcon.

Table of Contents

Appendix A	
What's New with 3D-MC	2-vii
Introduction	1-1
Keyboard Functions	1-2
Alphanumeric Keyboard	1-3
Numeric Keyboard	1-4
File Menu Options	2-1
Copying Project Files	2-1
Creating a Project File	2-3
Importing Project Files	2-4
Exporting Project Files	2-7
Control Point Files	2-11
Importing Control Point Files	2-11
Layers	2-17
Importing Layers	2-17
Surface Files	2-20
Creating Crown Road Surface Files	2-27
Creating Triangulated Surfaces From a Topo Survey File	2-30
Creating an As-Built Surface	2-36
Selecting an Active Surface File	2-41
Selecting an Active Alignment File	2-42
Selecting an Active As-built File	2-43
Control Menu Options	3-1
Setting As-built Control Options	3-1
Setting Blade Control	3-3
Automatic Best-Fit Blade Control	3-3
Setting Steer Indication Options	3-8
Blade Wear Adjustment	3-10
Calibrate Sensors	3-12

Valve Offset Calibration	3-14
Boost Settings	3-16
Tools Menu Options	4-1
Changing Radio Channels	4-1
Checking the Blade's Position	4-4
Navigating Points	4-6
Navigating to Points Using the Navigate to Point Context Menu	4-8
Performing Topographic Surveys	4-9
Using Supervisor Mode	4-12
Changing the Password	4-15
Locking Menus, Buttons and Screen Items	4-16
Isolate Surface	4-19
View Menu Options	5-1
Changing Main Window Display Views	5-2
Changing Left Window Display Views	5-4
Changing the Grade Indicator Scale	5-5
Changing the Right Window Display	5-8
Changing the Lower Window Display	5-9
Display Options	5-11
Working Surface Display Options	5-12
Alignment Display Options	5-14
As-built Surface Display Options	5-16
Points Display Options	5-18
Background Color Display Options	5-19
Units Display Options	5-20
Viewing and Updating 3D-MC	5-21
3D-MC Options	5-21
Main Screen Display Options	5-23
Elevation Control Key	5-24
Elevation Control Key	5-25
Slope Control Key	5-25
Viewing GPS Information	5-26
Adjusting Valve Gain	5-31
Adjusting Cut/Fill Offsets	5-32
Changing the Cut/Fill Offsets Using the Set-Points Pop-Up Menu	5-33
Steering/Grading to Polyline	5-35

Steering to Polyline:	5-35
Grading to Polyline	5-37
GPS+	6-1
GPS+ Components	6-1
Grader	6-1
Grader Schematic	6-3
Dozer	6-4
Dozer Schematic	6-5
Elevation Control Key	6-5
GPS+ Setup and Usage	6-6
Creating a Machine Configuration File	6-6
LD-40 Light Bar Support	6-13
Twin Antenna Setup	6-15
mmGPS+	7-1
mmGPS Components	7-2
Grader	7-2
Grader Schematic	7-3
Dozer	7-4
Dozer Schematic	7-5
mmGPS 3D Paver Components	7-6
Paver Schematic	7-7
Elevation Control Key	7-8
Slope Control Key	7-8
Creating a mmGPS Machine Configuration File	7-9
Setting PZL-1 Transmitter Options	7-18
Setting PZS MC Receiver Options	7-20
3D-MC²	8-1
3D-MC ² Components	8-1
Dozer Schematic	8-2
3D-MC ² Setup and Usage	8-4
Creating a Machine Configuration File	8-4
LPS	9-1
LPS Components	9-1
Grader	9-1
Grader Schematic	9-3
Dozer	9-4
Dozer Schematic	9-5
Elevation Control Key	9-6

Slope Control Key	9-6
Creating a Machine Configuration File	9-7
Viewing TS Information	9-13
LPS Position Tab	9-14
LPS Search Tab	9-15
2D	10-1
2D Components	10-1
Grader	10-1
Grader Schematic	10-3
Dozer	10-4
Dozer Schematic	10-5
Slope Control Key	10-5
2D Setup and Usage	10-6
Surveying Grade	10-7
Excavator	11-1
Excavator – X-63/X-63i/X-33	11-1
X-63 Components	11-2
X-63i Components	11-3
X-33 Components	11-4
Elevation Control Key	11-5
Adjust Elevation	11-5
X-63/X-63i/X-33 Machine Setup	11-7
Machine Radio Antenna Setup	11-7
MC-R3 Controller Box Setup (X-63)	11-8
MC-i3 GNSS Receiver Setup (X-63i/X-33)	11-10
Creating an X-63/X-63i/X-33 Machine Configuration File 11-11	
Excavator – X-62/X-32	11-24
X-62 Components	11-25
X-62 Schematic	11-26
X-32 Components	11-27
X-32 Schematic	11-28
Elevation Control Key (2D)	11-29
Adjust Elevation Screen (2D)	11-29
Slope Profiles	11-40
Known Slope	11-40
Measured Slope	11-42

Complex Slope	11-43
Referencing	11-45
Zero to Bucket	11-45
Zero to Laser	11-46
Reverse Slope Direction	11-47
Troubleshooting	A-1
Base Station	A-2
GX-60 Control Box	A-6
MC-R3 Controller/Receiver	A-14
MC ² Sensor	A-18
GPS Localization	A-18
Blade Response	A-23
MC-R3/MC-i3 Configurations	A-25

What's New with 3D-MC

The following list briefly describes new features and functions for 3D-MC, Version 10.0, usable only with the GX-60 and the MC-R3.

- Enhanced screen colors and fonts (see “Display Options” on page 5-11 for details)
- MC² for motor graders supported (see “Slope Control Key” on page 7-8 for details)
- Twin Antenna for MC² Dozer (see “Twin Antenna Setup” on page 6-15 for details)
- New machine support for: (see “Creating a Machine Configuration File” on page 9-7 for details)
 - Concrete Pavers
 - Trimmers
 - Curb & Gutter machines
 - Compactors
 - Elevating Scrapers
 - Dual Tow Scrapers
- Isolate surfaces and extend grade (see “Isolate Surface” on page 4-19 for details)

- Adjust Blade Wear (see “Blade Wear Adjustment” on page 3-10 for details)
- Support for other Base Station manufacturers (see “Advanced GPS Options (Advanced tab)” on page 5-30 for details)
- DGPS Support (see “Importing Layers” on page 2-17 for details)
- Upgraded features for As-Built upgrade surfaces (see “As-built Surface Display Options” on page 5-16 for details)
- New display options for active surfaces (see “Creating an As-Built Surface” on page 2-36 for details)
- New Control options for Cut/Fill to Surface (“Normal to Surface” on page 11-44 for details)
- TS-1 support added for supervisor truck (see “Viewing TS Information” on page 9-13 for details)
- DWG file import
- Other Features:
 - Automatic setup of NTRIP Virtual Port
 - New Network RTK types supported (select between VRS and (Leica) MAC types)

-
- New Light Bar (LD-40) Configurations (see “LD-40 Light Bar Support” on page 6-13 for details)
 - mmGPS Delete Transmitter Button added (see “Setting PZL-1 Transmitter Options” on page 7-18 for details)
 - Point Creation/Editing added
 - Increase in Valve Gains range
 - Set-Point Increments on Smart Knobs matches on-screen Raise/Lower buttons (see “Changing the Cut/Fill Offsets Using the Set-Points Pop-Up Menu” on page 5-33 for details)
 - Blade Trim Adjustments added for Smart Knobs

Notes:

Introduction

3D-MC is the software interface between the operator and the machine's components. The menus and keys allow files to be created, updated, superimposed, copied, or deleted. Information and files the operator can access will be store and continuously updated to either the internal memory or to a USB card.

This manual discusses the following 3D-MC systems:

- GPS+ (motor grader and dozer)
- mmGPS (motor grader, dozer, and paver)
- 3D-MC² (dozer)
- LPS (motor grader and dozer)
- 2D control (motor grader and dozer)
- Excavator (X-63/X-63i/X-62)

Keyboard Functions

When entering text or numbers, one of the following two pop-up keyboards display:

- Alphanumeric keyboard – enter both letters and numbers.
- Numeric keyboard – enter numbers only.



Alphanumeric Keyboard

1. To access the alphanumeric keyboard from any field, click in the field.



A configuration dialog box with a yellow header titled "Configuration name/type". It contains several fields: "Configuration name:" with the text "Dozer2"; "Machine type:" with a dropdown menu showing "Bulldozer"; "Sensor type:" with a dropdown menu showing "GPS Antenna"; "Mounting location:" with a dropdown menu showing "Middle of blade"; and "Units of measure:" with a dropdown menu showing "Feet". At the bottom right are "Next" and "Cancel" buttons.

2. Press in the field to enter the letters or numbers on the keyboard.



Numeric Keyboard

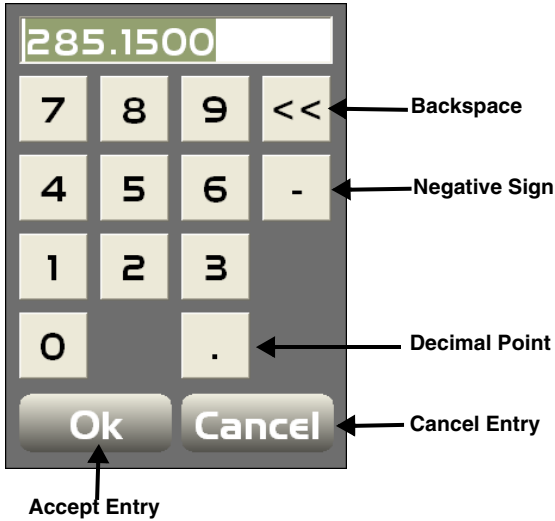

1. To access the numeric keyboard from any field, click in the field.



2. Press the numbers on the keyboard to type in a value, or use the arrow keys to increase the value incrementally

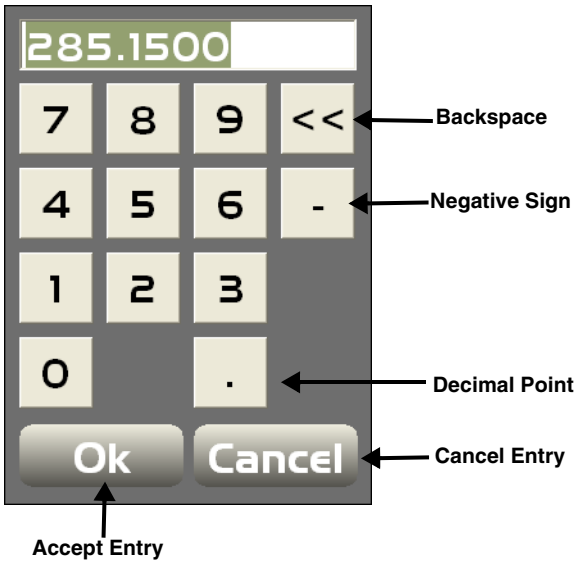

NOTE: When you press Ok on the keyboard, entered information becomes valid and the keyboard disappears.

File Menu Options

Before beginning work, you must have job files that contain various information needed to accurately grade the jobsite, which include project files, point files, design surface files, and machine configuration files.

Copying Project Files

To copy files from a USB key:

1. Press the green power button to turn on the display and insert the USB key into the GX-60 USB port.

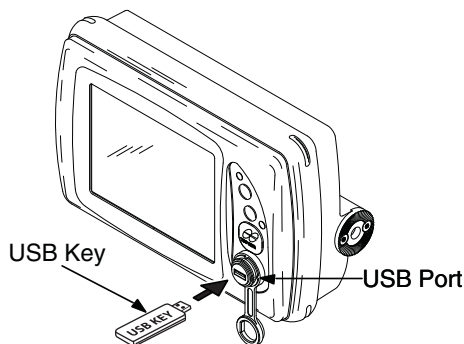

2. Press **Topcon Logo** ▶ **File** ▶ **Projects**.



3. Press **Copy** and select the location of the file to copy from.

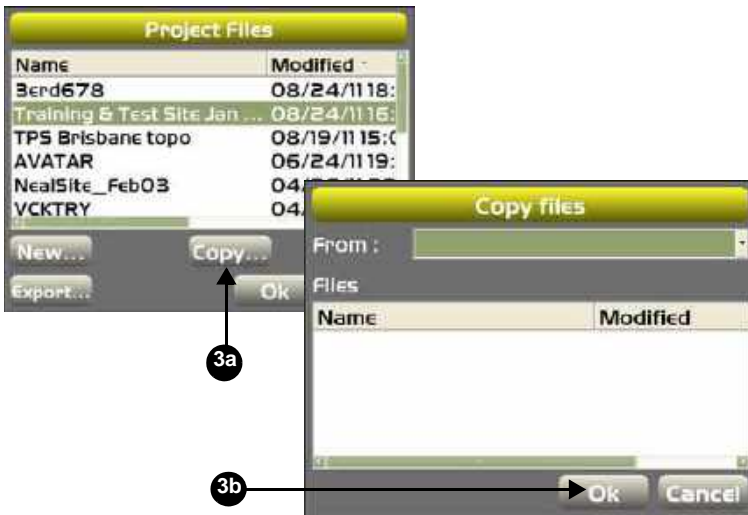

4. Select the file to copy and press **Ok**.

5. Select the files and press **Ok** again to apply the data to the current job.

NOTE: The process for creating a project file for all applications are basically the same.

Creating a Project File

1. You can create multiple project files.
2. Press **Topcon Logo** ▶ **File** ▶ **Projects**.



3. Press **New**.



4. Enter the Name of the project from the alphanumeric keyboard and press **Ok**.



Importing Project Files

The project engineer must provide a design surface file for the jobsite. The correct file must be copied into the GX-60 control box and selected as the project for the jobsite.

To import a project file into the MC-R3:

1. Insert the USB memory device containing the job files into the USB slot.

2. Press **Topcon Logo** ▶ **File** ▶ **Projects** on the Main Screen.

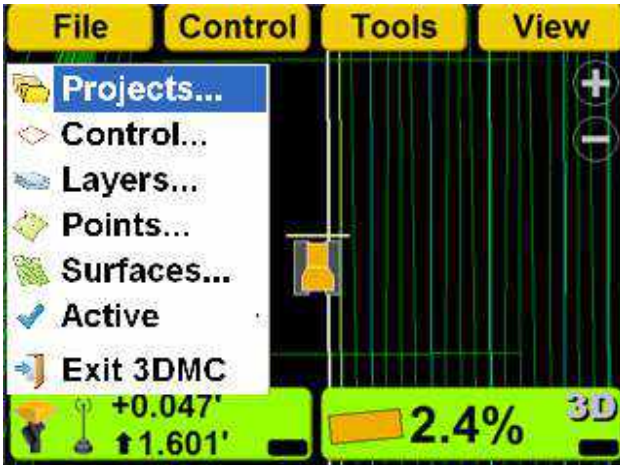

3. On the *Project files* dialog box, press **Copy**.



On the *Copy files* dialog box select “*from data card to internal disk*” from the Copy drop-down list.

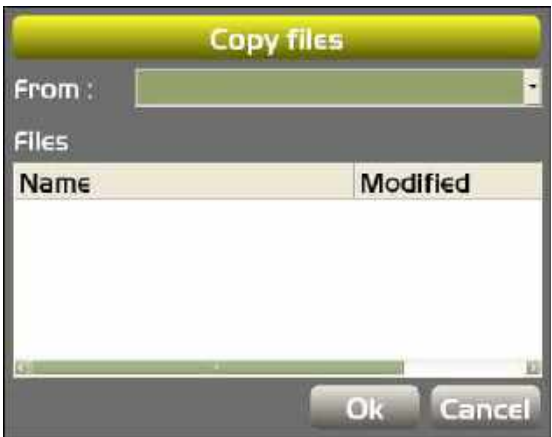

Exporting Project Files

Export project files to a data card (recommended), or to the internal disk, for use with Pocket-3D or other applications.

1. Press **Topcon Logo** ▶ **File** ▶ **Projects**.



2. Press **Export**.



3. Select the location (*Where*) of the export.



4. Press **All** to select or deselect files to export, or choose an individual file and press **Select** to

change the selection to **Yes** (export) or **No** (do not export).



Select/Deselect
Individual Files

Select/Deselect All

- 3D-MC allows the user to rename the exported file. Choose a file, and press **Rename**.



- 6. Enter the new name of the file and press **Ok**.



- 7. Press **Ok** to export the files and return to the *Export Project Files* screen.



Control Point Files

Control points are required in 3D-MC and is usually imported into 3D-MC with a project file. Control point files can also be imported into 3D-MC individually from an external device or from the internal disk.

Importing Control Point Files

To import a control point file:

1. If importing from a USB key, insert the key into the GX-60.

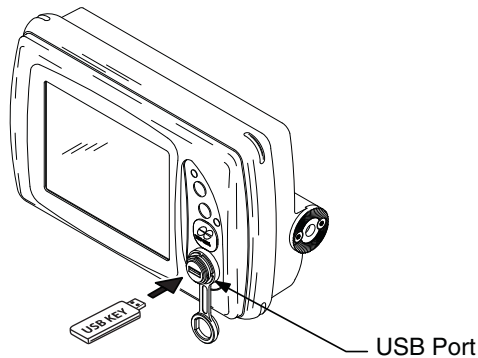

2. Press Topcon Logo ▶ File ▶ Control.



3. Press **Import**.



4. Select the file type (*What*) and location (*Where*) from the drop-down list, and then select the file name to import and press **Ok**.

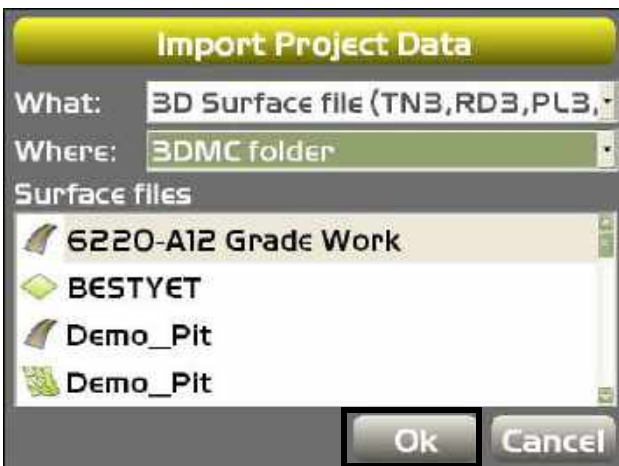

5. Press **Ok** to apply the data to the current job.

- To add a new control point, press **Add** and enter a name for the control point file.

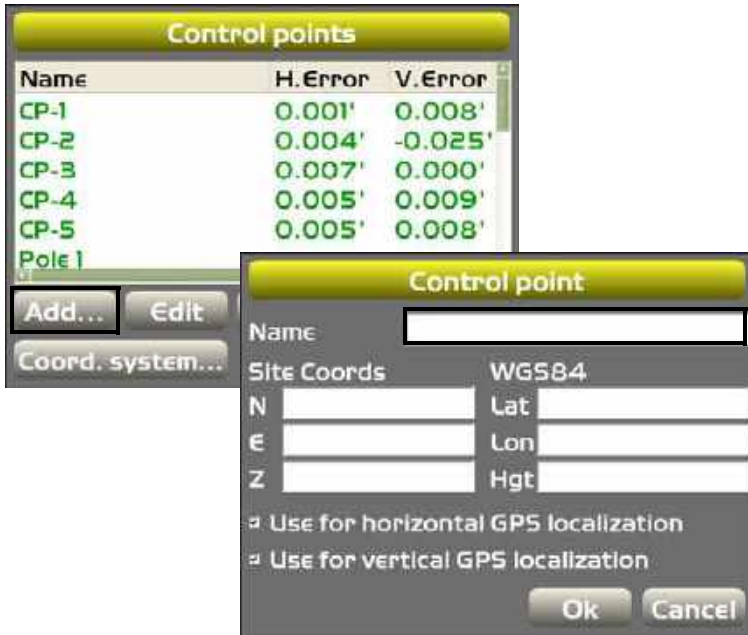

- Enter the following information for the control point on the *Control point* dialog box.
 - Site coords – enter the coordinates for northing (N), easting (E) and elevation (Z)

- WGS84 – if you have precise GPS coordinates, enter the coordinates for latitude (Lat), longitude (Lon) and height (Hgt)
- Localization check boxes – only enable these if currently performing a GPS localization
- **Ok** – press to return to the *Control points* dialog box.

Control point

Name

Site Coords: WGS84

N Lat

E Lon

Z Hgt

Use for horizontal GPS localization

Use for vertical GPS localization

8. To edit a control point press **Edit** on the *Control points* dialog box.

Enter new site coordinates or GPS coordinates and press **Ok** to return to the previous screen.



Layers

A layer in 3D-MC contains point data and/or linework data.

Importing Layers

Layers are usually imported into 3D-MC with a project file. Layers can also be imported into 3D-MC individually from an external device or from the internal disk.

1. Press **Topcon Logo** ▶ **File** ▶ **Layers**.



2. Press **Import**.



3. Select the file type (*What*) and the location of the file (*Where*) to import from the drop-down menu. Then select the file to import, and press **Ok**.

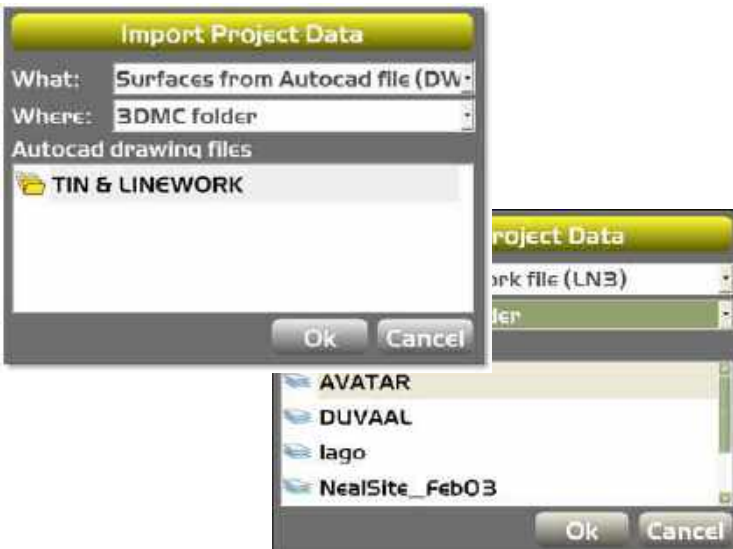

You can directly import TIN surfaces and linework from AutoCad DWG files.

4. Select individual point or linework files to change their color, symbol, and whether or not to show the layer. Press **Ok** to return to the Main Screen.



Surface Files

Surface File Types



Flat Plane Surface/Sloping Plane Surface:

A planar (flat) surface with a 0% crossslope and mainfall. This surface is primarily used for building pads.

A sloping surface with cross slopes and mainfall based on a reference elevation.



Crown Surface File:

A crown surface file allows the user to define a centerline and to add a simple cross section including width and cross slope.



TIN Surface From Topo Survey File:

A TIN surface represents a surface as a network of non-overlapping triangles. Within each triangle the surface is represented by a plane. The triangles are made from a set of points called mass points.



As-built Surface file:

A color map of the graded surface.

Importing Surface Files

1. Press **Topcon Logo** ▶ **File** ▶ **Surfaces** on the Main Screen.



2. On the *Project Surfaces* dialog box, press **Import**.



3. Select the file type (*What*) and the location of the file (*Where*) to import from the drop-down menu. Then select the file to import, and press **Ok**.



Creating Flat or Sloping Surface Files

1. Press **Topcon Logo** ▶ **File** ▶ **Surfaces** on the Main Screen.



2. To create a new Flat or Sloping surface file, press **New** on the *Project Surfaces* dialog box.



3. On the *Surface Name and Type* dialog box, enter a name for the surface file from the alpha-numeric pop-up keyboard and select surface type (*Flat plane surface or Sloping plane surface*). Press **Next**.

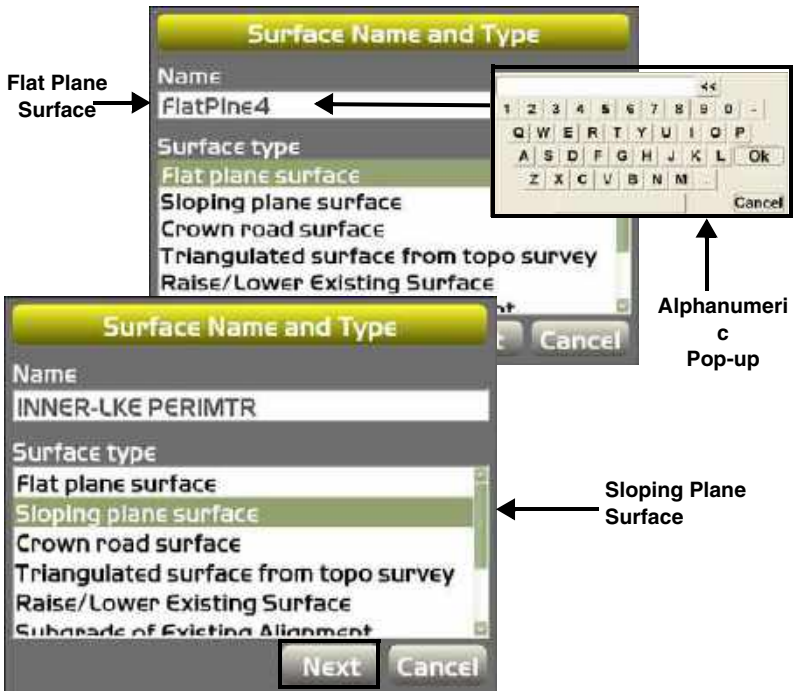

NOTE: You may enter any known values or move to point **A** or **B** and press **Measure pt.**

The image displays two overlapping screenshots of a machine control interface. The top screenshot is titled "Flat Plane Surface" and features a "Point on surface" section with input fields for N, E, and Z, and a "Grid interval" field set to 65.62'. Below these are "Measure" and "Select" buttons, and a "Back" button at the bottom. The bottom screenshot is titled "Sloping Plane Surface" and includes a "Point on surface" section with N, E, and Z input fields. It also has a "Main-fall (A -> B)" section with "Direction" set to 0°00'00" and "Grade" set to 0.000%, and two buttons labeled "A" and "B". The "Grid Interval" is 65.617' and the "Crossfall" "Grade" is 0.000%. At the bottom are "Back", "Finish", and "Cancel" buttons. In both screenshots, the "Measure" and "Select" buttons are highlighted with a black box.

4. Enter the reference point coordinate values or move the machine to the elevation reference point.
5. On the Sloping Plane surface, move the machine to either point **A** or point **B** and position the blade on the cutting edge.

- When the cutting edge rests on the point, press either **A** or **B** to measure the point.

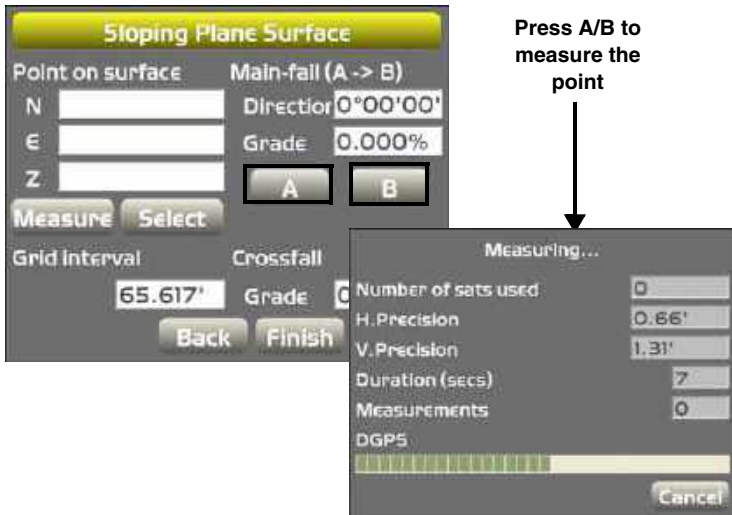

- For the Flat Plane surface file, enter a *Grid interval* for the Main Screen. Press **Finish**.



- For the Sloping Plane surface, enter parameters for the *Grid interval* and the *Crossfall or* Press **Select** to choose a file from the *Points list* dialog box. Press **Finish**.

Sloping Plane Surface

Point on surface Main-fall (A -> B)

N 4673.928' Direction 0°00'00'

E 10596.499' Grade 0.000%

Z 377.633' A B

Measure Select

Grid Interval Crossfall

65.617' Grade 0.000%

Back Finish Cancel

Creating Crown Road Surface Files

1. To create a Crown surface file, press **Topcon Logo ▶ File ▶ Surfaces** on the Main Screen.
2. Press **New** on the *Project Surfaces* dialog box.

NOTE: You may enter any known values or move to point **A** or **B** and press **Measure pt.**

3. On the *Surface Name and Type* dialog box, enter a name for the Crown surface file from the alphanumeric pop-up keyboard and select surface type (*Crown road surface*).
4. Press **Next**.

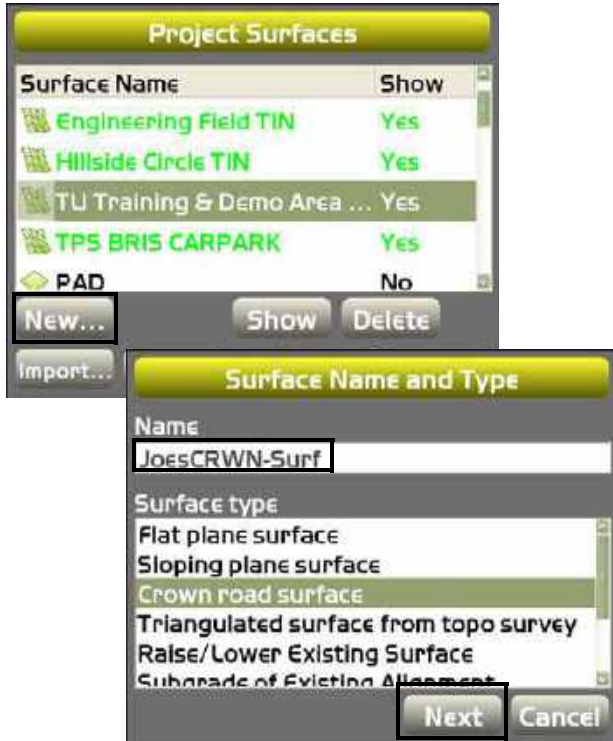

5. On the *Crown Surface* dialog box, move the machine to either point **A** or point **B** and position the sensor on the cutting edge on the selected point.

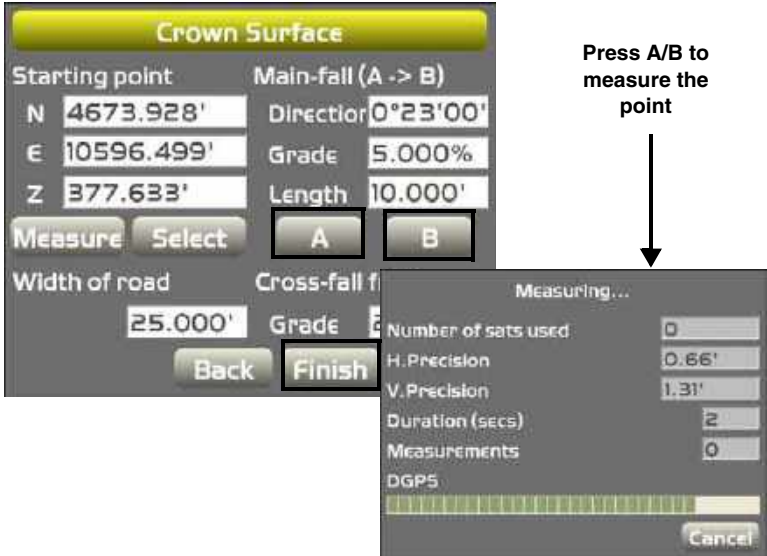

6. When the cutting edge rests on the point, press either **A** or **B** to measure the point, then press **Finish** to return to the previous screen.

Creating Triangulated Surfaces From a Topo Survey File

1. To create a triangulated surface from a topo survey file, press **Topcon Logo** ▶ **File** ▶ **Surfaces** on the Main Screen.
2. Press **New** on the *Project Surfaces* dialog box.
3. On the *Surface Name and Type* dialog box, enter a name for the TIN surface file from the alphanumeric pop-up keyboard and select surface type (*Triangulated surface from topo survey*).
4. Press **Next**.

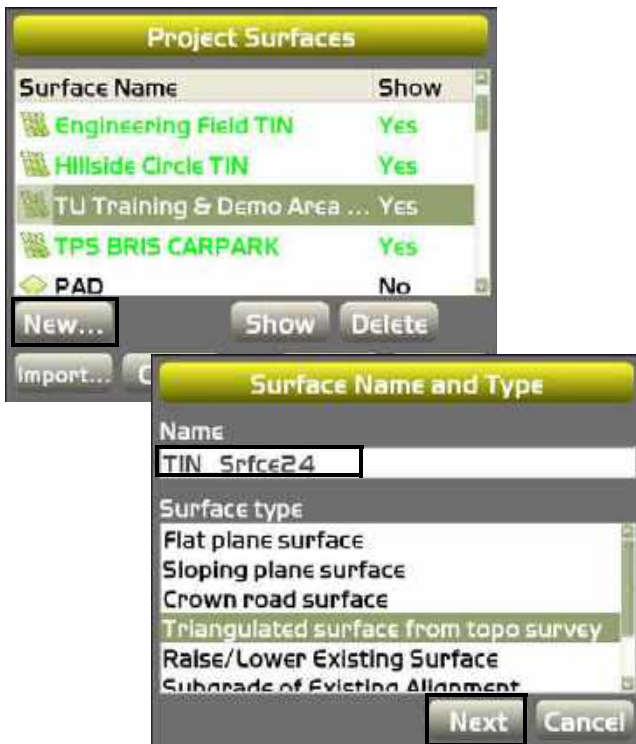

5. On the *Triangulation of Topo Points* dialog box, select a layer containing the points to be used.
6. Press **Finish** to return to the previous screen.



Raising or Lowering an Existing Surface

1. To raise or lower an existing surface from a topo survey file, press **Topcon Logo** ▶ **File** ▶ **Surfaces** on the Main Screen.
2. Press **New** on the *Project Surfaces* dialog box.
3. On the *Surface Name and Type* dialog box, enter a configuration name for the file from the alphanumeric pop-up keyboard and select '*Raise/Lower Existing Surface*' as surface type .
4. Press **Next**.



5. On the *Raise/Lower Surface* dialog box, enter an elevation adjustment value for the existing surface.
 - A positive number raises the subgrade in comparison to the working/reference surface, which is applied to the centerline of the working/reference surface.
 - A negative number lowers the subgrade in comparison to the working/reference surface, which is applied to the centerline of the working/reference surface.
6. Press **Finish** to return to the previous screen.



Subgrade of an Existing Alignment

1. To subgrade an existing alignment from a topo survey file, press **Topcon Logo** ▶ **File** ▶ **Surfaces** on the Main Screen.
2. Press **New** on the *Project Surfaces* dialog box.
3. On the *Surface Name and Type* dialog box, enter a name for the subgrade alignment file from the alpha-numeric pop-up keyboard and select surface type (*Subgrade of Existing Alignment*).
4. Press **Next**.



5. On the *Subgrade of Existing Alignment* dialog box, select the road surface to use as the reference from which to create the surface.
6. Enter an elevation adjustment value for the existing surface.
 - A positive number raises the subgrade in comparison to the working/reference surface, which is applied to the centerline of the working/reference surface.

- A negative number lowers the subgrade in comparison to the working/reference surface, which is applied to the working/reference surface.
7. Select a grade type:
- Manual – if enabled, enter the percentage of the Left/Right side of the subgrade element, which determines the slope for the left/right side of the machine or the road.
 - Copy from – if enabled, use the gradient (grade) of the reference cross-section element that matches the entered offset value (lateral offset from centerline). The left/right grade is copied from the existing road.
8. Select the slope extension for both left and right side.
- If vertical is selected, the cross section of the subgrade stops at the same horizontal offset as the cross section of the reference surface.
 - If Continue is selected, the last element of both surfaces selected in the ‘Maximum extension’ entry box is continued.
 - Use this option if there are more intersection points expected beyond the end of the cross section.

9. Press **Finish** to save the new surface file and end the process.

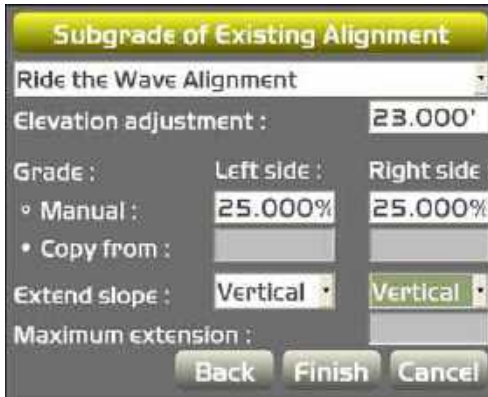

Creating an As-Built Surface

1. To create an As-Built surface for an active design file, press **Topcon Logo** ▶ **File** ▶ **Surfaces** ▶ **New as-built for active design surface** on the Main Screen.
2. Press **New** on the *Project Surfaces* dialog box.
3. On the *Surface Name and Type* dialog box, enter a name for the active design surface file from the alpha-numeric pop-up keyboard and select surface type New as-built for active design surface.

4. Press **Next**.



5. Origin – enter Northing/Easting coordinates.

You can create the as-built surface grid directly in 3D-MC, rather than from 3D Office. The origin of the grid can be defined by Measuring the coordinates of the machine's current location by entering Northing (*N*) and Easting (*E*) coordinates.

6. **Measure** – press to measure the coordinates of the machine's current location.
7. **Select** – press to select the point of origin from the *Points* list as opposed to measuring the point
8. Dimensions – define the dimensions with a number of grid cells by entering a number for *X/Y* directions.
9. Grid interval – enter a value here to define the size of each grid cell.

10.Orientation – manually enter an orientation value or press ‘A’ (start of grid); drive to another location and press ‘B’ (end of grid).

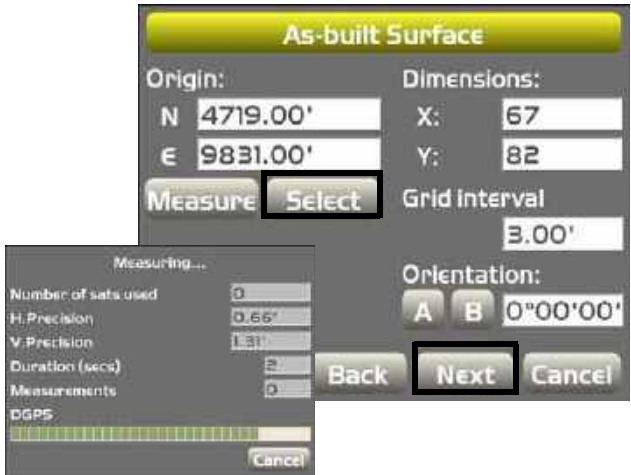

11. On the second *As-Built Surface* dialog box, enable one of the following:

- Empty (don't preload elevation data) – if this option is enabled, no elevation data is defined for each cell.
- Preload with constant cell elevation – if this option is enabled, cells are loaded with a constant value.
- Preload elevations from another surface – if this option is enabled, you can select another surface from which to load elevations.

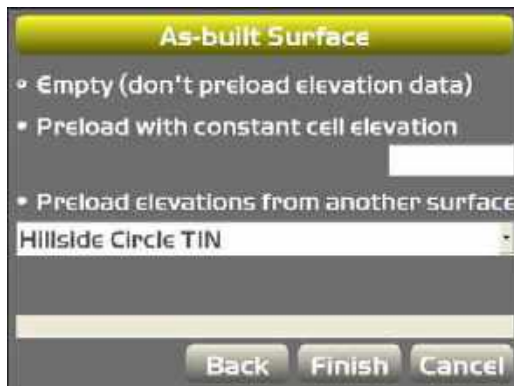

1. To create an as-built surface to match the extents of an existing as-built or to match the current design surface, click **Topcon Logo**
▶ **File** ▶ **Surfaces** ▶ **New as-built to match active as-built** on the Main Screen.

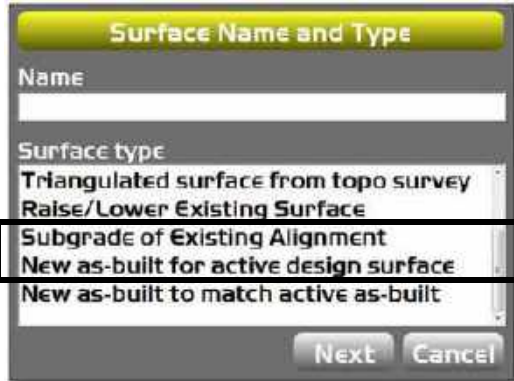

Selecting an Active Surface File

1. To select an active surface file, press **Topcon Logo ▶ File ▶ Active ▶ Surface**.



2. Select the surface file you want to be active on the Main Screen.

Selecting an Active Alignment File

1. To select an active alignment file, press **Topcon Logo ▶ File ▶ Active ▶ Alignment**.

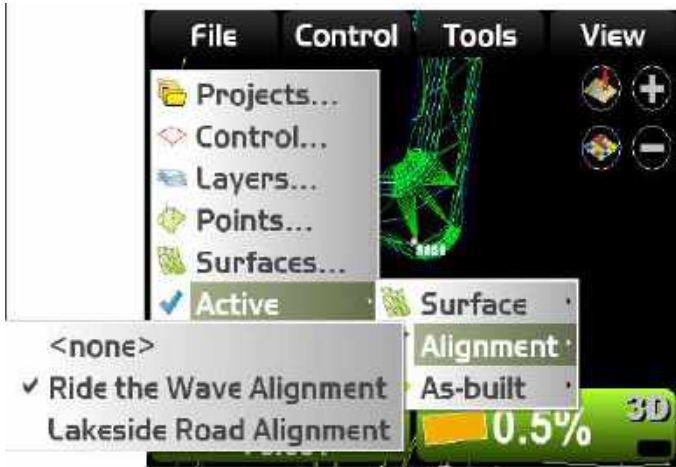

2. Select the alignment file you want to be active on the Main Screen.

Selecting an Active As-built File

As-built surface files display a colored map of the graded surface.

1. Press **Topcon Logo** ▶ **File** ▶ **Active** ▶ **As-built**



2. Select the as-built file you want to be active on the Main Screen.

Control Menu Options

In the control menu, you can create, edit, copy, and delete machine setup files. If a road file is selected as the reference surface, you can set road subgrade properties. It is also here, where the PZS-MC receiver and the PZL-1 laser transmitters are configured. In addition, the slope sensor can be calibrated, valve offsets applied, and 2D control enabled.

Setting As-built Control Options

Display settings for “as-built” files must be set first in the File menu before you can set options in the Control menu.

1. Press **Topcon Logo** ▶ **Control** ▶ **As-built Control**



2. Select your As-built Control update options, then press **Advanced** to view *Surface Cache* options.

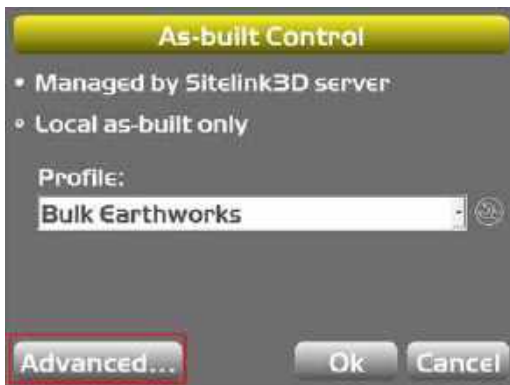

3. Select a *Project* and *Layer Name*, and tap **Ok**.



Setting Blade Control

Automatic Best-Fit Blade Control

When using the automatic best-fit method, 3D-MC uses the entire cutting edge of the blade as the elevation reference.

1. Press **Topcon Logo** ▶ **Control** ▶ **Blade control**.



2. To allow for precision grading when a design surface has breaklines, enable **Best-fit (whole blade)** on the **Blade Control** dialog box.



- To grade to an area where the Design Surface is smaller than the blade itself, enable *Control using single point on blade*.



When using the control using single point on blade method, 3D-MC uses a selected point on the blade to use as the elevation reference rather than the entire cutting edge of the blade.

- To quickly change the blade control point when the section view is active:
 - Press and hold the edge of the blade for one second, to move to the far left or far right edge of the blade. On the pop-up menu, tap **Move control left** or **Move control right**.

- Press and hold a point on the blade for one second. On the pop-up menu, tap **Move control**.



- To change the blade control point using the slider-button or left/right arrows on the *Blade Control* dialog box:



- With *Control using single point on blade* selected, hold the slider button and move it left or right or use the left/right arrows to select a point at a distance from the left/right side of the blade.
- Press **Ok** to apply this blade control point to the machine.

Setting Steer Indication Options

3D-MC can be used to steer the machine to and pave to a polyline layer in the Linework file. Typically, you use an Alignment file to pave along an alignment line. Polylines represent features or objects, such as building pads, curbs, sidewalks, the top/toe of slopes, or any boundary on the project. If the polyline is composed of three dimensional information at each transition point, it can be selected on the main screen and used as the alignment line to steer to or as the design elevation to control the blade.

1. Press **Topcon Logo** ▶ **Control** ▶ **Steer indication**.



2. On the *Steer Indication* dialog box, select or enter the following parameters. Then press **Ok**.
- Point of Interest – select the edge of the blade to steer from
 - Alignment feature – select the feature to steer to
 - Additional steer offset – enter an offset from the feature to apply
 - Override machine – selecting either Up Station/Down Station locks the machine orientation to be parallel to the Centerline.

In this mode there is no need for the machine to move before the orientation is calculated.

NOTE: If blade orientation is miscalculated, grade design is undercut, causing the blade of the machine to cut incorrectly.

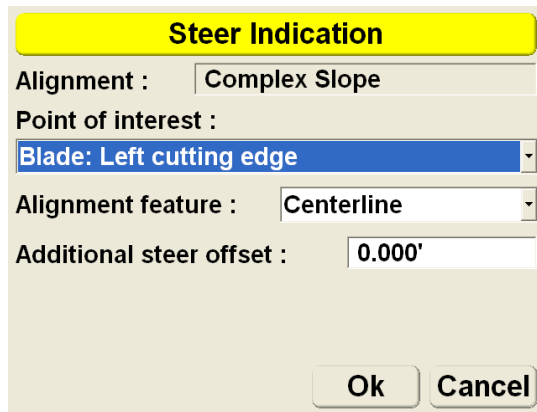

The image shows a dialog box titled "Steer Indication" with a yellow header. It contains the following fields and controls:

- Alignment :** A text box containing "Complex Slope".
- Point of interest :** A dropdown menu with "Blade: Left cutting edge" selected and highlighted in blue.
- Alignment feature :** A dropdown menu with "Centerline" selected.
- Additional steer offset :** A text box containing "0.000'".
- At the bottom right, there are two buttons: "Ok" and "Cancel".

Blade Wear Adjustment

To enter a “Wear” adjustment value, press **Topcon Logo** ▶ **Control** ▶ **Blade Calibration** ▶ **Blade wear**.



Although the *trim* value is entered as a positive number, it gets subtracted from the overall height of the mast.

NOTE: You can now bench out to a point with known elevation and calculate the blade wear value to apply.

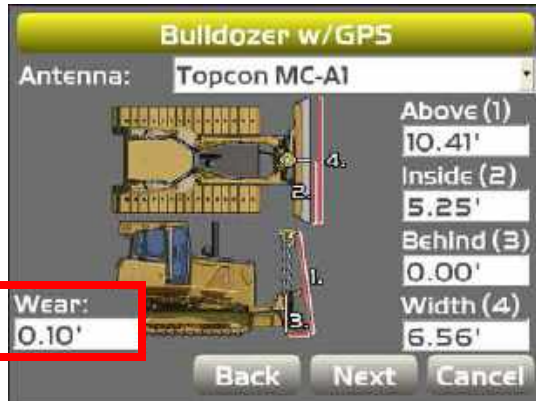

On the *Blade Wear Check* dialog box, you can bench out to a point with known elevation and calculate the blade wear value to apply.

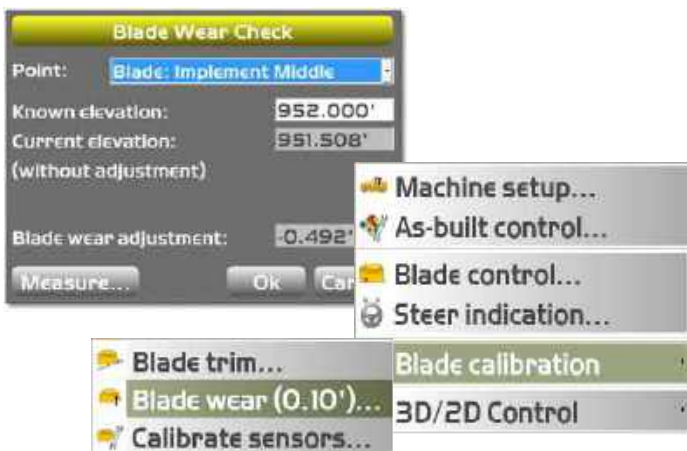

NOTE: The **Calibrate sensors** menu option is for calibrating 2D sensors on a machine. For further information, refer to the **Installation & Calibration Manual** for specific applications.

NOTE: Blade wear check accuracy is subject to fluctuations/errors of the measurement method used.

Calibrate Sensors

To calibrate 2D sensors on a machine, press **Topcon Logo ▶ Control ▶ Blade calibration ▶ Calibrate sensors**.

Follow the instructions on First/Second blade positions.

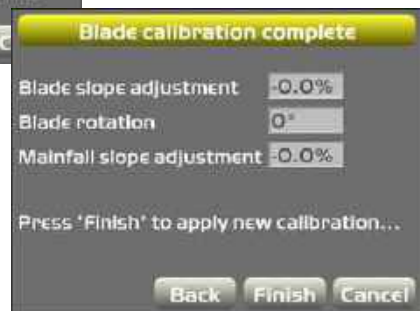
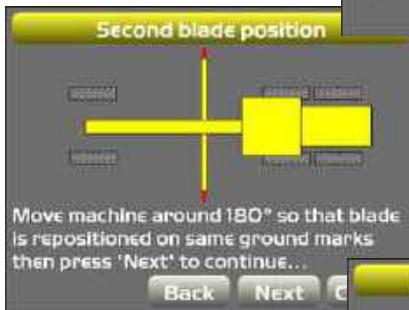
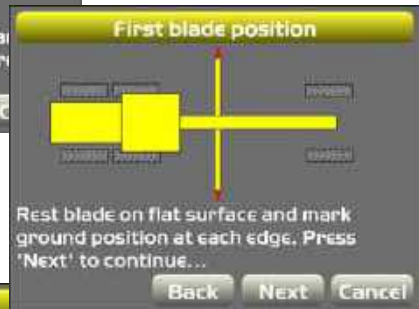
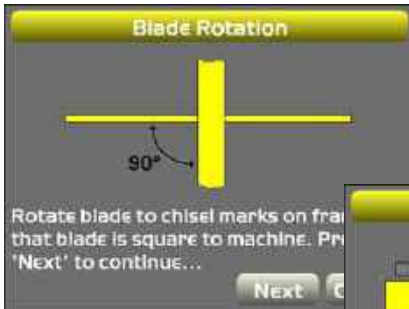

Valve Offset Calibration

1. Raise the machine blade so that both sides of the cutting edge rest a few inches above the ground.
2. On the main screen, Press **Topcon Logo ▶ Control ▶ Valve offsets.**



3. Press the **Raise elevation Set** button and tap the up/down arrows to increase or decrease the valve offsets or enter a value into the pop-up numeric keyboard.



4. Repeat Step 3 for *Lower elevation*, *Raise slope*, and *Lower slope* parameters.
5. Press **Ok**.

CAUTION: Since the blade is about to move automatically, **HANDS** and **FEET** should be clear of the blade!

Boost Settings

For System Five dozers with poor valve response, the Boost settings option can be used. This Valve Boost (Amplitude) will send a quick valve command for a very short duration to improve valve response for Elevation, Slope, or both.

- Enter the *Duration* of the Valve Boost in milliseconds.
- Enter the *Amplitude* using the same scale as Valve Offsets, then select either *Apply Boost to both directions* or *Apply Boost to Raid direction only*.

The value entered for the Amplitude should be slightly higher in order to function properly. Setting the Amplitude to a value less than the Valve Offsets will have either a delayed reaction or provide no valve reaction.



- Press **Defaults** for automatic entry.

NOTICE: Boost Settings may cause poor machine performance and should not be used unless machine and valve type have been identified as having poor valve response. Consult your dealer before making adjustments.

Tools Menu Options

The Tools menu contains options for collecting topographic points, checking the position of the blade/screed, and configuring the radio. This menu is not active for 2D applications.

Changing Radio Channels

1. Press **Topcon Logo** ▶ **Tools** ▶ **Configure radios**.

NOTE: LPS modem settings and UHF modem settings will appear differently.



2. Select the same **Radio type** that was chosen for the MC-R3, then press **Configure**. 3D-MC will connect to the radio after several seconds.

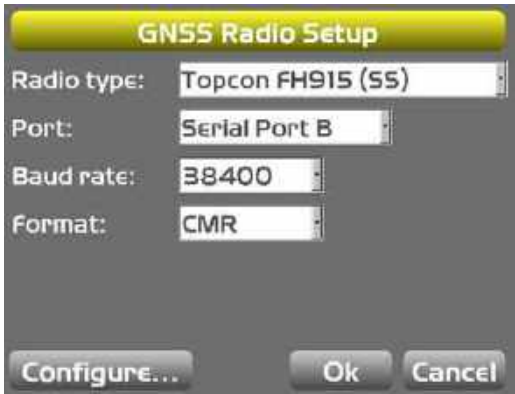
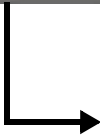
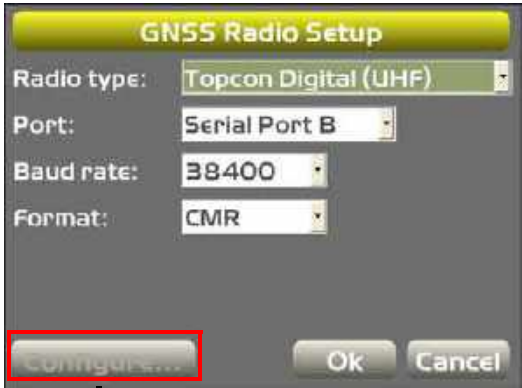

3. Enter radio configuration information, and select the channel that matches the channel of the Base Station.



4. Press **Advanced** to select the country of operation, then press **Ok**.
5. Press **Set** to save the radio configuration settings and return to the GPS Radio Configuration screen.



6. Press **Ok** to save the radio configuration settings and return to the Main Screen.

Checking the Blade's Position

1. To check the position of the blade, press **Topcon Logo** ▶ **Tools** ▶ **Position check**.



2. On the **Position Check** dialog box, select the Point of interest (either **Blade:Left**, **Blade Middle**, Blade Right, and press **Measure**.

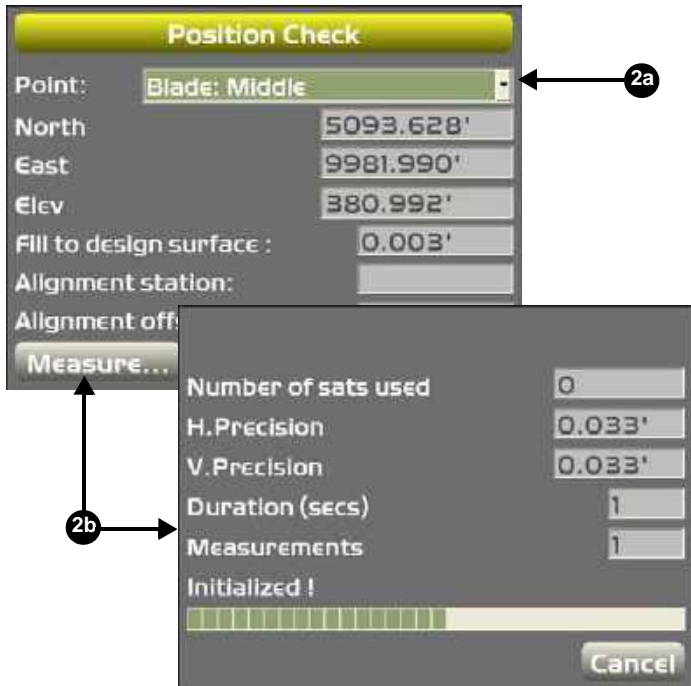

3. When finished, the **Position Check** dialog box displays the point on the job at the selected edge of the blade.
4. Press **Save** to display the **Position Details** dialog box to select a layer name and a point description.

Navigating Points

A list of points can be selected for navigation/stakeout. The list can be created by selecting points from any layer in the project file.

1. Press **Topcon Logo** ▶ **Tools** ▶ **Navigate**.
2. Click **Add/Remove** to either add or remove point(s) to the stakeout listing.
3. Highlight the point.
4. Press **Ok**.



Stakeout information will display on the Main Screen. The machine will be drawn with an additional cross-hair to indicate point of reference.

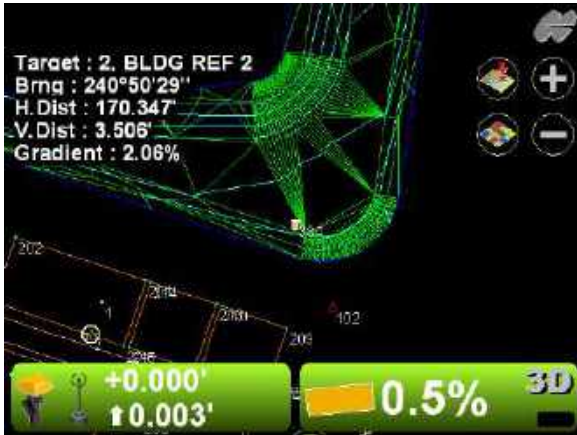

5. Press **Topcon Logo** ▶ **Tools** ▶ **Stop navigation** to stop the navigation of points.

Navigating to Points Using the Navigate to Point Context Menu

You can navigate to a point(s) from the Main Screen.

1. On the Main Screen, click on the points you want to navigate.
2. Right-click and hold on the mouse to display the Context pop-up menu.
3. Highlight **Navigate to point**. The points navigation results displays on the Main Screen.
4. To stop the navigation, right-click and hold on the mouse anywhere on the main screen and highlight **Stop navigation** on the context pop-up menu to stop the navigation of points.

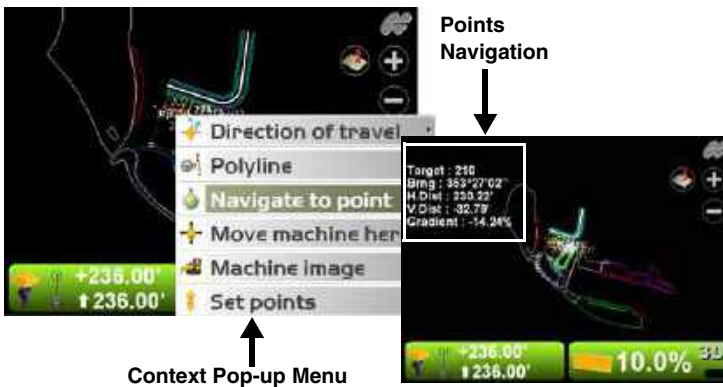

Performing Topographic Surveys

To perform a topo survey, you must first create or select an existing point file.

1. Press **Topcon Logo** ▶ **File** ▶ **Layers**.



2. Create a new point file or select an existing point file on the *Project Layers* dialog box.
3. Press **Ok** to return to the Main Screen.



4. Press **Topcon Logo** ▶ **Tools** ▶ **Topo survey**.



5. Enter or select topo survey parameters. Press **Ok** when done.



6. Press **Ok** to start the topo survey function.

NOTE: If Auto topo by time is selected, press **Ok** to start the topo survey function.

NOTE: If auto topo by distance is selected, begin driving.

When the machine begins to move, 3D-MC will begin measuring and logging the data.

7. To stop topo measurements, press **Topcon Logo ▶ Tools ▶ Stop topo survey**. Otherwise, 3D-MC continues logging measurements.



Using Supervisor Mode

Using Supervisor mode in 3D-MC, a supervisor can disable menus, buttons and screen items from the user. A password is needed to access Supervisor mode. Passwords are case sensitive.

1. The default password is: *topcon*
2. Press **Topcon Logo** ▶ **Tools** ▶ **Supervisor**.



3. Enter the password using the keyboard, and press **Ok**. Press **Ok** at the prompt.

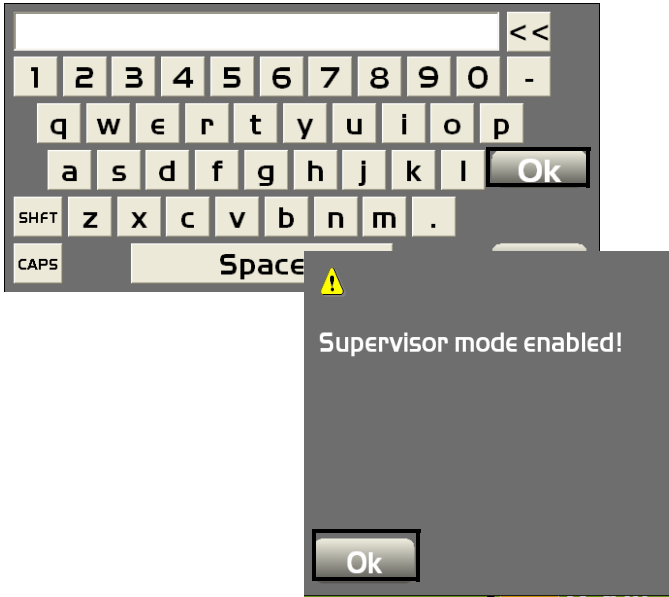

4. Press **Topcon Logo** ▶ **Tools** ▶ **Supervisor** to access the Supervisor menu.



Changing the Password

1. Press **Topcon**

Logo ▶ **Tools** ▶ **Supervisor** ▶ **Change password.**

Press **Ok** at the prompt.

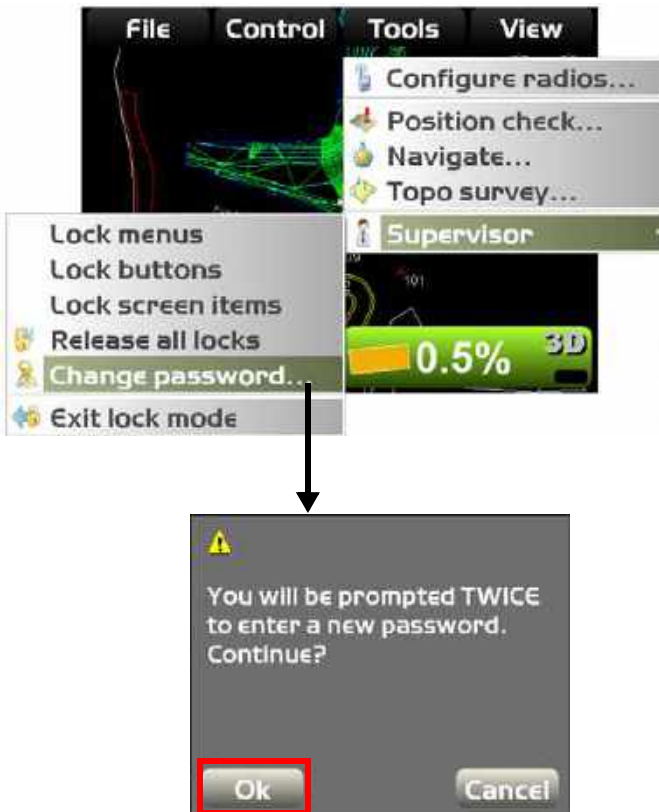

2. Enter the new password twice, and press **Ok**.

Locking Menus, Buttons and Screen Items

- Menu – a selection from the **File**, **Control**, **Tools**, or **View** menu.
 - Button – a button on various 3D-MC screens, such as the **Edit** button on the *Machine Files* screen.
 - Screen item – an alphanumeric entry field or drop-down menu.
3. Press **Topcon Logo** ▶ **Tools** ▶ **Supervisor** ▶ **Lock menus/buttons/screen items**. Then press **Ok**.



4. Press menus, buttons, or screen items to disable. The selections display as red when locked. Press the menu again to unlock. The menu will no longer display as red.



5. When you are finished locking, press **Topcon Logo ▶ Tools ▶ Supervisor ▶ Exit lock mode.**

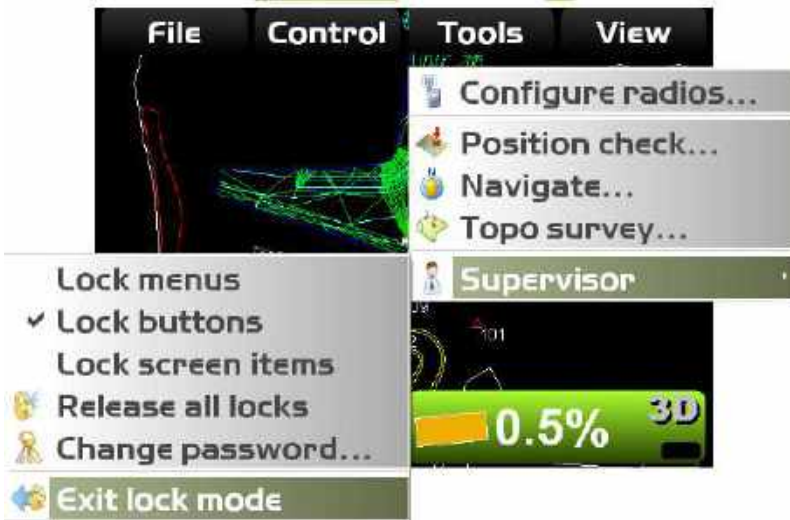

Isolate Surface

You can isolate a small piece of the active (TIN) surface and effectively ignore any triangles outside of this isolated region.

1. Press and hold down the mouse to display the popup menu.
2. Select Isolate surface from the context menu.

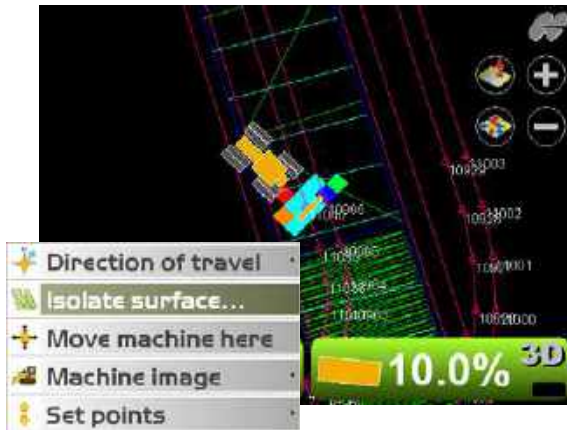

On the *Isolate Surface Region* dialog box, do the following to isolate the surface:

- **Maximum grade transition** – enter a maximum deflection value between adjacent triangles in the TIN surface.
- **Extend grade at edge by** – enter a value to extend the grade of the isolated region by.
- **Surface/Extension color** – press to select a color to represent the surface and the newly selected extension.



- Press **Ok** to return to the main screen.

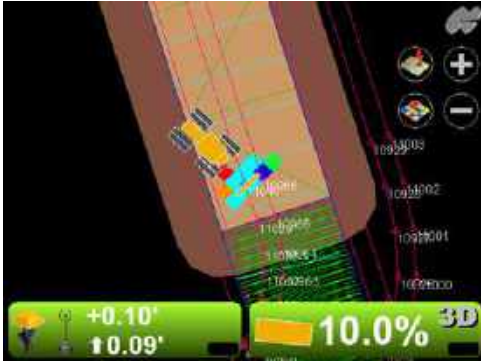

Before Surface
Isolation routine

- To end the routine, press and hold the mouse on the main screen.
- On the pop-up context menu, highlight **Stop isolating**.



After Surface
Isolation routine

View Menu Options

3D-MC can display several types of views, each of which contain useful information. From the View menu, you can do the following:

- display the Plan, Section, Profile, or 3D views in the Main window
- display the Profile, Section, Grade Indicator, or 3D from the Left window
- view the grade indicator from the Right window
- display the Profile, Section, 3D, Light bar, or Cut/fill history (for mmGPS applications) from the Lower window
- select Display options for various data, depending on the files selected for display
- view 3D-MC information, authorization codes, and options from the About 3D-MC menu option

Changing Main Window Display Views

To access the main window view, press **Topcon Logo ▶ View ▶ Main window**, then press the necessary view; a check mark indicates the active view.



Plan View

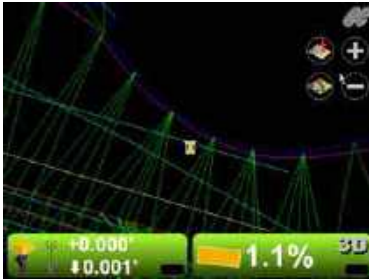

Section View

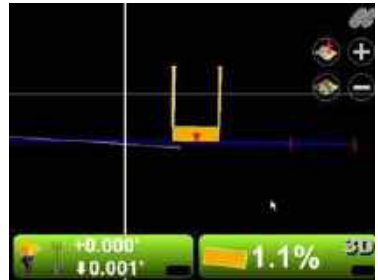

Profile View



3D View



Changing Left Window Display Views

To access the lower window view, press **Topcon Logo** ▶ **View** ▶ **Left window**, then select a view.



Profile View

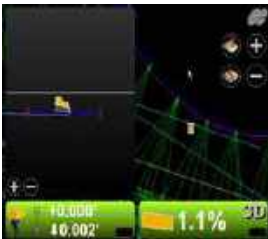

Section View

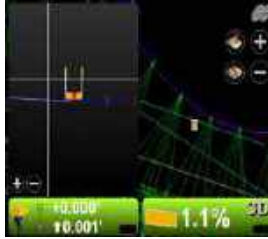

Grade Indicator



3D View

Changing the Grade Indicator Scale

To view the grade indicator, press **Topcon Logo ▶ View ▶ Left window ▶ Grade indicator or Topcon Logo ▶ View ▶ Right window ▶ Grade indicator**.



To change the grade display, press and hold the grade indicator for one second, tap **Grade display**, then the desired option. This option applies a cut/fill reference for a position on the cutting edge.

- At left edge – the grade tape follows the left-edge position of the blade/screed.
- In from edge – the grade tape follows a position on the blade/screed an entered distance from the left edge. Tap to display the numeric pop-up keyboard to enter a distance from the left edge.

To change the on-grade or extents press and hold the grade indicator for one second, then tap the desired menu option.

- On-grade – displays the current on-grade (green zone) width. Tap to change the on-grade width.
- Extents – displays the current scale (unit spacing) for the grade indicator. Tap to change the unit spacing.
- Invert colors – tap to reverse the colors of the grade indicator.

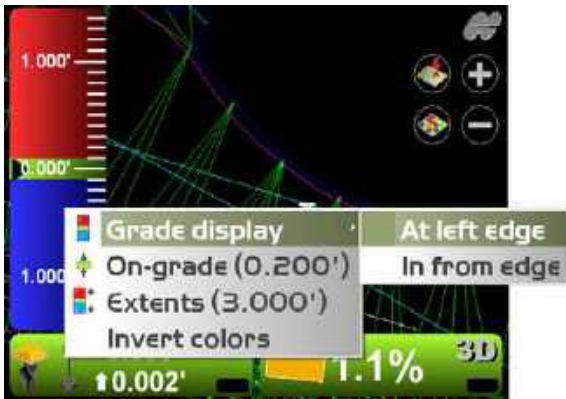

To change the Light Bar Scale and Extents To view the light bar scale:

1. Press **Topcon Logo** ▶ **View** ▶ **Lower window** ▶ **Light bar**.
2. Press and hold the light bar scale for one second, then click **Green**, **Yellow**, or **Extents** to change the scale color.



Changing the Right Window Display

To access the right window view, press **Topcon Logo** ▶ **View** ▶ **Right window**, then select **Grade indicator**.

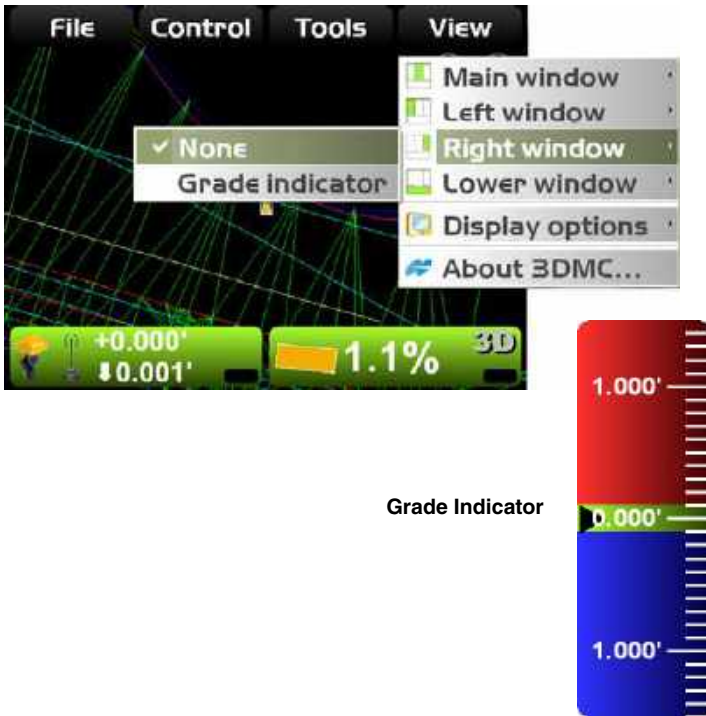

Changing the Lower Window Display

To access the lower window view, press **Topcon Logo** ▶ **View** ▶ **Lower window**, then select a view.



Profile View

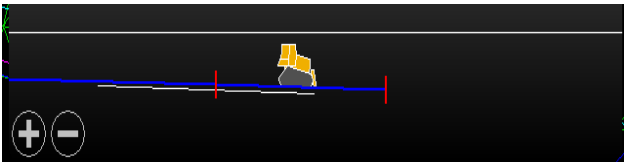

Section View

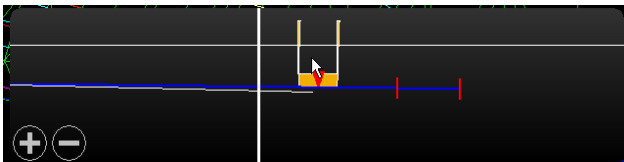

3D View



Light Bar Scale



Display Options

To view available display menu options, press **Topcon Logo** ▶ **View** ▶ **Display options**.



Working Surface Display Options

1. Press **Topcon Logo** ▶ **View** ▶ **Display options** ▶ **Working surface** when using a surface file.



2. On the *TIN* tab, press the **Color** buttons to change *Show triangle mesh*, *Show boundaries/breaklines*, or *Show contours at interval* to enable grade transition markers on/off for TIN parameters.
3. On the *Section* tab, press the **Color** button to change the *Section/profile line color* and/or *Show grade transitions* to enable grade transition markers on/off for road surfaces.

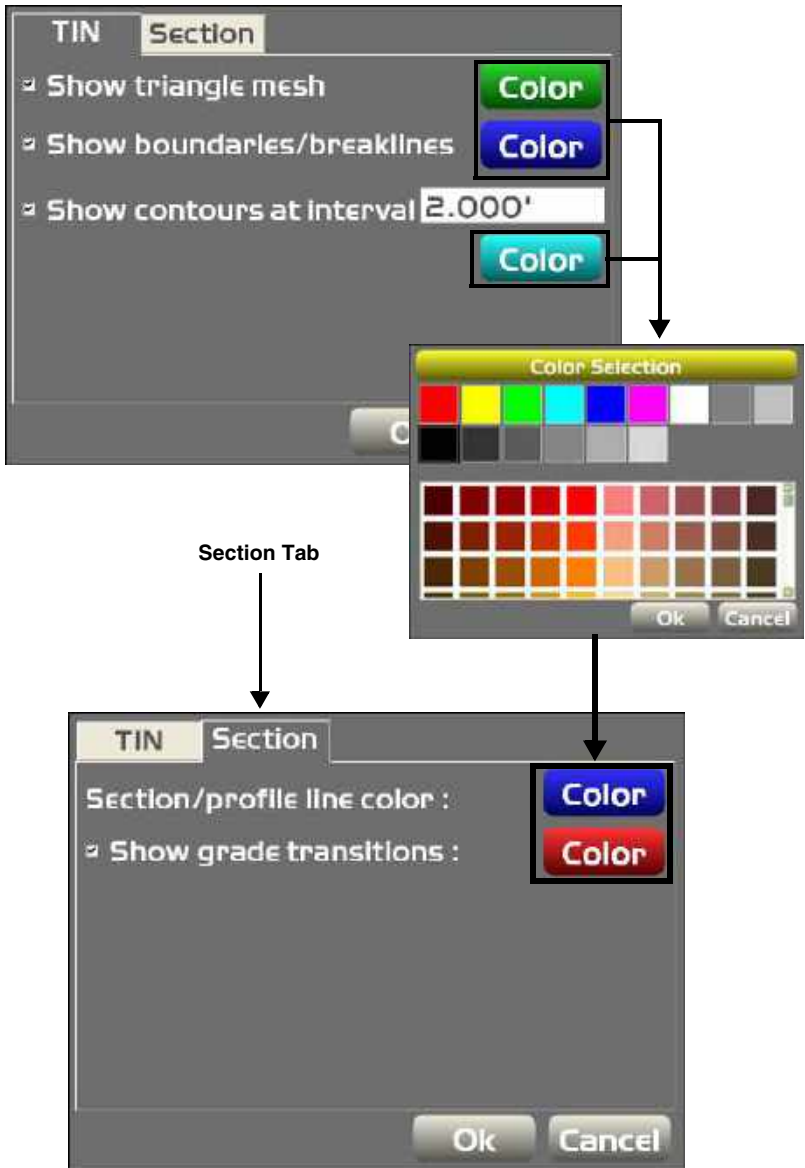

Alignment Display Options

1. Press **Topcon Logo** ▶ **View** ▶ **Display options** ▶ **Alignment** when using an alignment file.



2. On the **Road** tab, press the **Color** button to change the color of the alignment and station lines. Select a color from the **Color Selection** screen and press **Ok**.

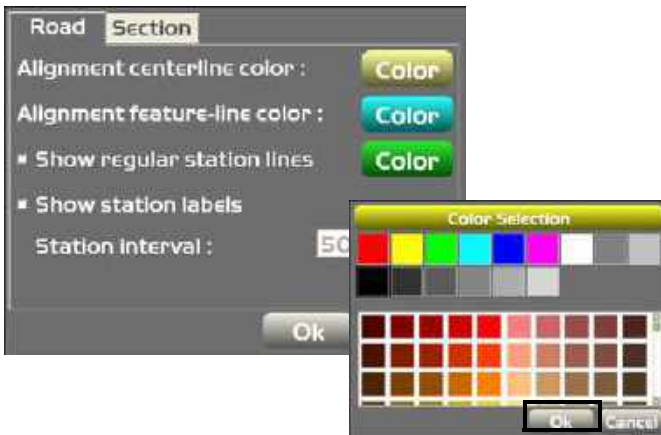

3. On the *Section* tab, press the **Color** button to change the *Section/profile line color* and/or *Show grade transitions* to enable grade transition markers on/off for road surfaces



As-built Surface Display Options

1. As-built surface files display a colored map of the graded surface.
1. Press **Topcon Logo** ▶ **View** ▶ **Display Options** ▶ **As-built surface**.



2. Select and/or enter the necessary options and press **Ok**.



NOTE: A total of 13 colors can be used for cut-fill, number of passes, pass difference, etc.

3. Press any **interval** button to change colors.

Points Display Options

1. When using a Point file, press **Topcon Logo** ▶ **View** ▶ **Display options** ▶ **Points**.



2. To display points symbols and/or point numbers during a topographic survey, select the corresponding check box and press **Ok**.

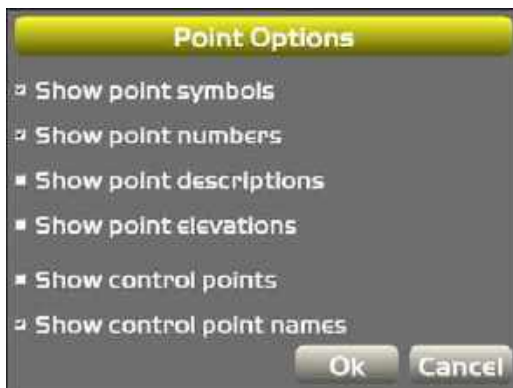

Background Color Display Options

1. To change the background color of the Main Screen, press **Topcon Logo** ▶ **View** ▶ **Display options** ▶ **Background color**.
2. Select a color from the *Color Selection* screen and press **Ok**.

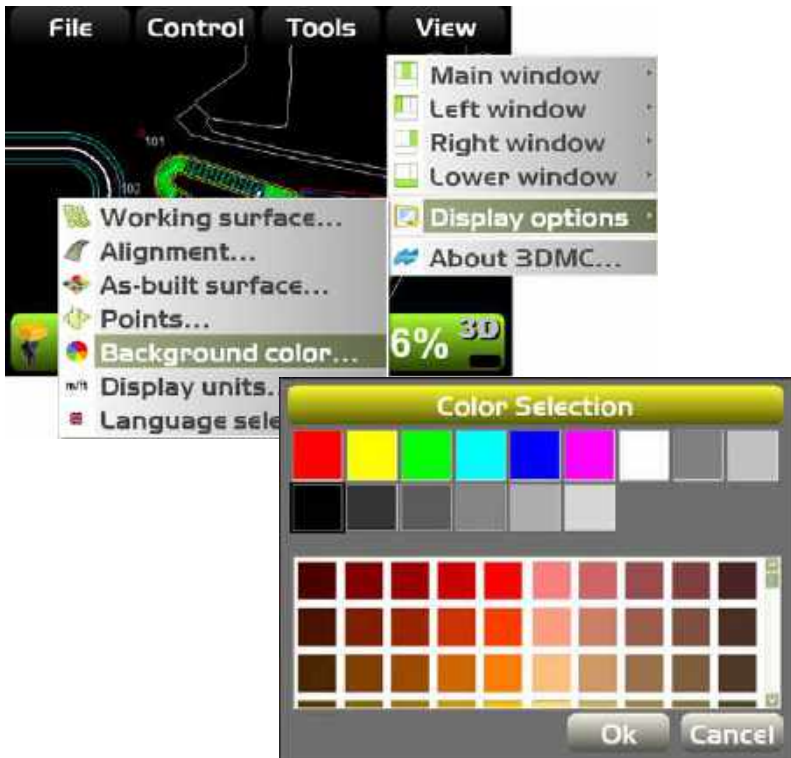

Units Display Options

1. To set the type of units used in the job, press **Topcon Logo** ▶ **View** ▶ **Display options** ▶ **Display units**.

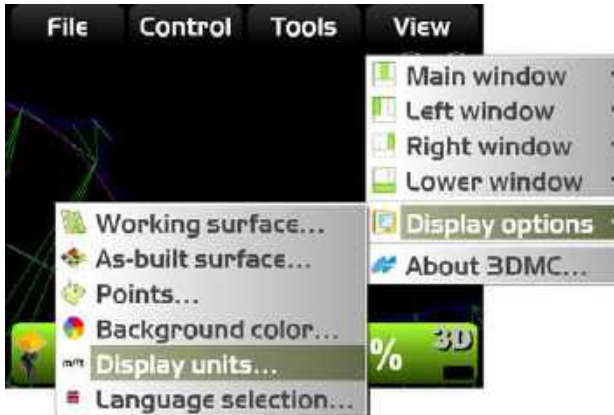

2. Select the display unit options from the drop-down box and press **Ok**.

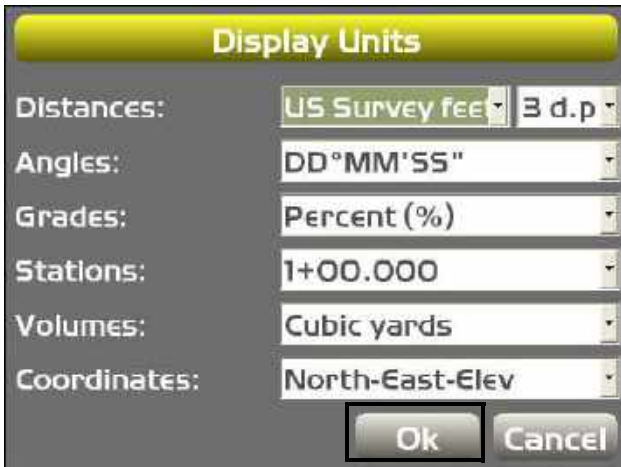

Viewing and Updating 3D-MC

To view information about 3D-MC, press **Topcon Logo** ▶ **View** ▶ **About 3DMC**.



3D-MC Options

1. To view the selected options, press **Options** on the *about 3DMC* dialog box.



- To modify 3D-MC options, press **Modify** on the *Options* dialog box.



- Record the *Device identification* number to give to your Topcon representative. Contact your Topcon representative to obtain new authorization codes for the necessary applications.



- After receiving the new authorization codes, enter the codes into the *ControlBox* dialog box or press the “**From File**” button to copy the authorization file from a USB drive.



- Press **Ok** to apply the new codes and options. Press **Ok** on each screen to return to the Main Screen.

Main Screen Display Options

The 3D-MC Main Screen has the following components: Main Window (the display varies, according to the selected file and display options), Tool Bar (icons for frequently used functions) and pop-up menus for various functions (depends upon the type of file open and the information selected).

Elevation Control Key

The Elevation Control key displays cut/fill readings and the cut/fill offsets for the elevation of the blade.

The key also indicates the status of the connected sensor with graphics, informational messages, and colors. The information that displays will be different, depending on the control application.

- Upper number – in 3D control, displays the current Cut/Fill Offset, and can be changed at any time. If the machine is incapable of cutting to the Design Elevation, the operator dials an offset into 3D-MC, raising or lowering the Design Surface for a more manageable cut or fill.
- Lower number – in 3D control, displays the current Cut/Fill Reading, or distance from finish grade. The number continuously updates according to the elevation difference between the cutting edge and the Design Surface.
- Single number – in 2D control, displays the current elevation setting, and can be changed at any time.
- Elevation Control Key color – the background color of the elevation control key indicates sensor status.
 - Green: indicates sensor status suitable for grading.

- Red: indicates an error status and Automatic Control will be disabled.
- Orange: in GPS/mmGPS applications, indicates low GPS precisions.
- Icon color – for mmGPS applications, the icon color will be BLUE when the system is receiving a mmGPS signal, and GRAY when a mmGPS signal is unavailable.
- Icon status – a crossed out icon indicates the corresponding sensor/receiver is not available. A flashing radio icon indicates the radio link is between three and ten seconds old (weak signal).

Elevation Control Key



Slope Control Key

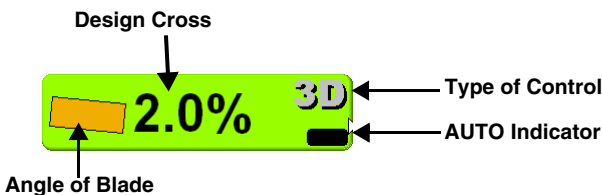

Viewing GPS Information

1. Press the **Elevation control** key.



- Press the **GPS info** button to view the *GPS Information* tabs.

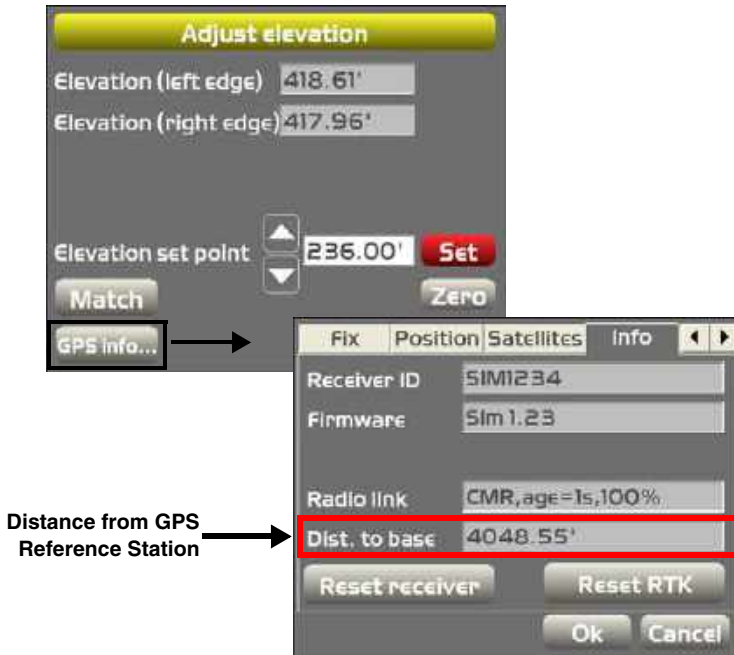

- GPS Status and Quality (Fix tab)

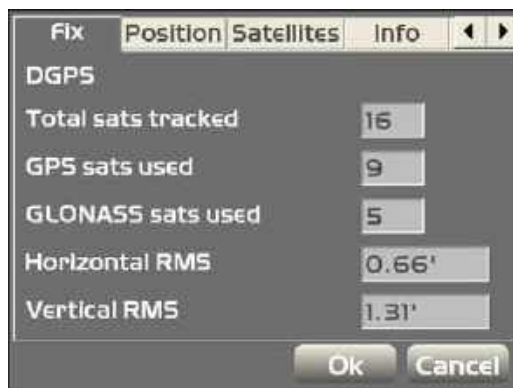

- Cutting Edge Position (Position tab)

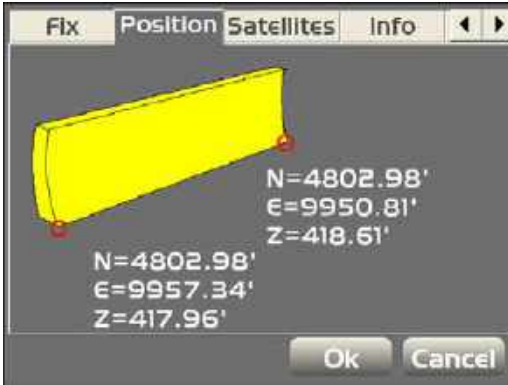

- Monitor Satellites and Enter Mask Angle (Satellites tab)



- View Receiver Information or Reset Receiver (Info tab)

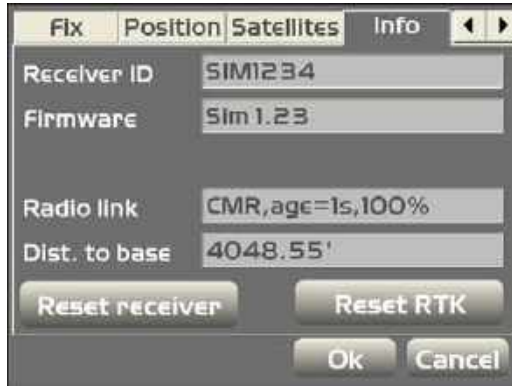

- Satellite Planning Information (Planning tab)

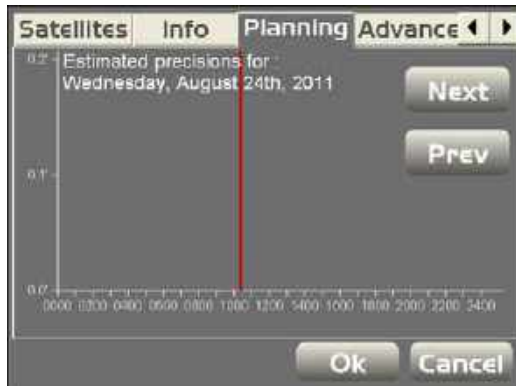

N O T E : The Red vertical line marks the current time.

- Advanced GPS Options (Advanced tab)

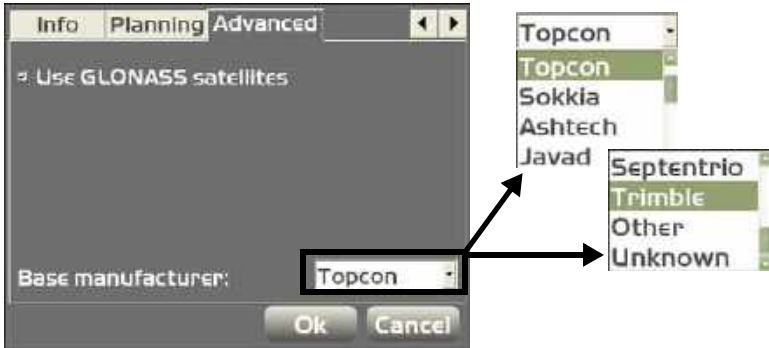

NOTE: You can now enable/disable the tracking of GLONASS satellites. This option affects ALL GLONASS satellites, not just individual ones.

NOTE: From the Base manufacturer drop-down box, you can select which GPS reference station manufacturer to use, i.e., Topcon, Sokkia, Trimble, etc., which aids with RTK operation where GLONASS is used at the base and rover, but the base is NOT a Topcon base.

Adjusting Valve Gain

1. Press the **Elevation Control** key on the 3D-MC Main Screen.

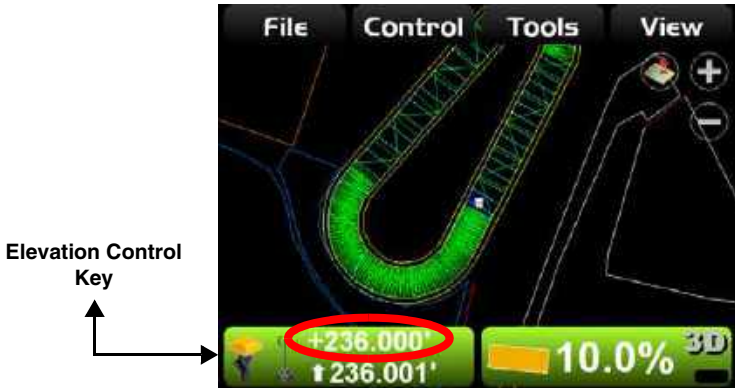

2. Press the *Elevation valve gain (raise/lower) Set* button on the *Adjust Elevation* screen (changes to red).



3. Change the offset using the up/down arrows, then press **Set** to lock in the value.
4. Press **Ok** to return to the Main Screen.

Adjusting Cut/Fill Offsets

1. On the 3D-MC Main Screen, press the **Elevation Control** key.

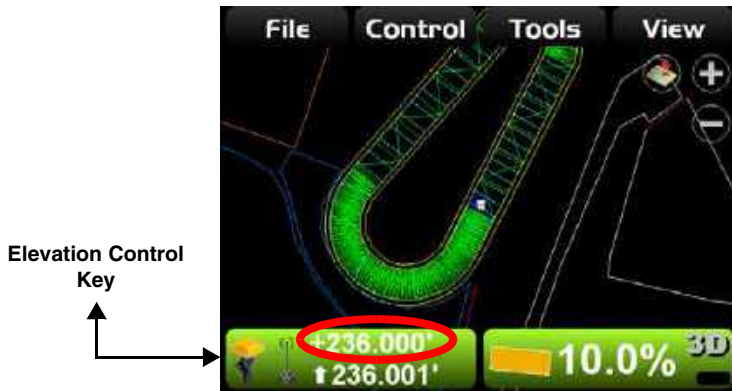

2. Press the **Elevation set point Set** button (changes to red).



3. Change the offset using the up/down arrows, then press **Set** to lock in the value.
4. Press **Ok**.

Changing the Cut/Fill Offsets Using the Set-Points Pop-Up Menu

1. The Set-points pop-up menu allows quick adjustment of the cut/fill offsets from the Main Screen.
2. To access, press and hold anywhere on the Main Screen.
3. Press **Set-points ▶ Enabled (left)** or **Enabled (right)** to display the set-point (cut/fill offsets) adjustment arrows. Enable the set-point arrows above the Elevation Control Key.

NOTE: Pressing the keys above the Slope Control Key has no effect in 3D.



4. Press the arrows to adjust the cut/fill offsets.

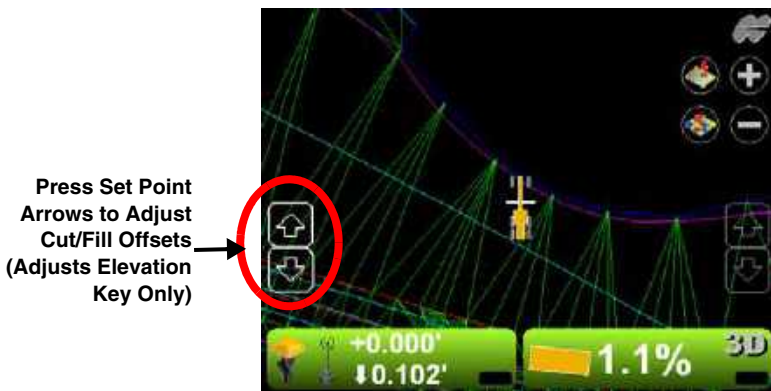

5. Press **Set-points** ▶ **Increment** to adjust the set-points increment.



Steering/Grading to Polyline

Steering to Polyline:

1. Press and hold the polyline to use for steering, then press **Steer to polyline** on the pop-up menu; graphical cross lines display along the selected polyline.



2. Press **Topcon Logo** ▶ **Control** ▶ **Steer indication** to change the steer indication settings.



3. Additional steering information can be set in the Cross section view.



Grading to Polyline

1. On the Main Screen, press and hold the polyline to use for grading to, then press **Polyline** on the pop-up context menu and select **Extend grade**.

Graphical cross lines display along the polyline.

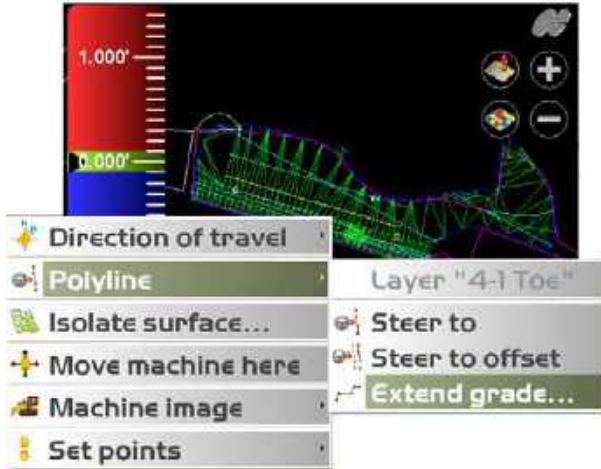

2. Begin grading. Repeat Step 1 above to grade to another polyline.

GPS+

GPS+ applications use satellite signals to determine location. A radio connection between a GPS Base Station and the GPS machine allows the GX-60 Control Box and the MC-R3 Controller to receive GPS corrections from the Base Station. With the corrections, the GX-60 and the MC-R3 can accurately determine the difference between the cutting edge and the design surface and control the blade to move just the right amount of material.

GPS+ Components

Grader

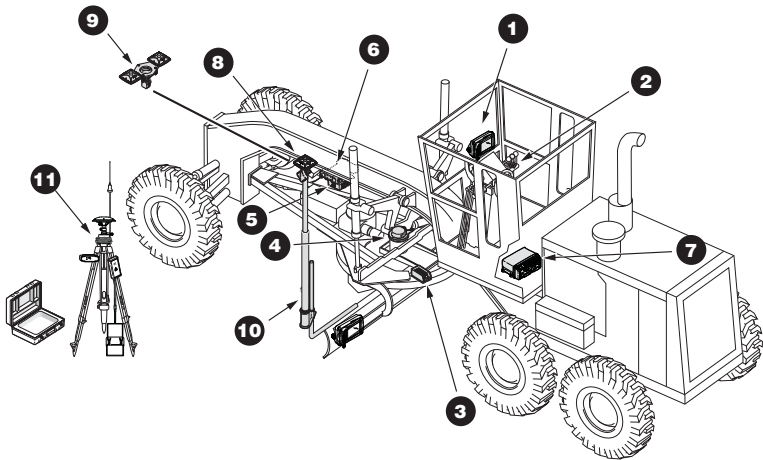

1. GX-60 Control Box
2. Remote Smart Knobs™
3. Blade Slope Sensor

4. Rotation Sensor
5. Mainfall Sensor
6. Hydraulic Manifold Assembly
7. MC-R3 Controller
8. MC-G3 Single Antenna
9. MC-G3 Dual Antenna
10. GPS Vibration Pole
11. Base Station Kit

Grader Schematic

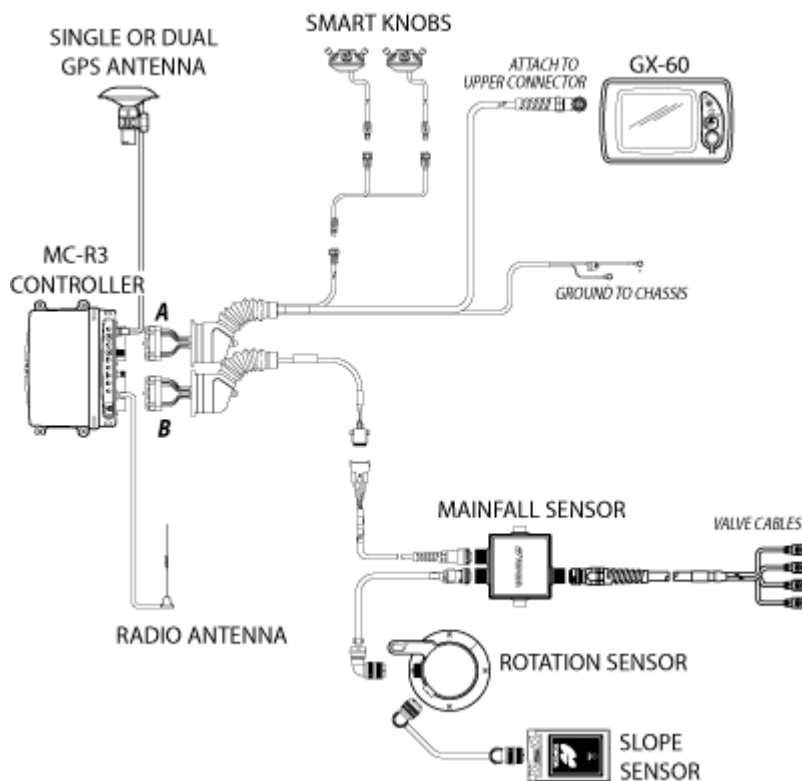

Dozer

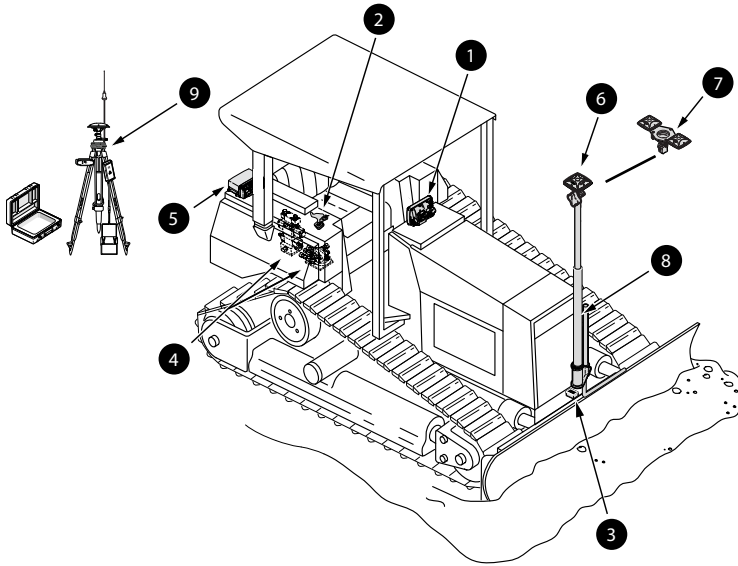

1. GX-60 Control Box
2. Simple Auto/Manual Knob
3. Blade Slope Sensor
4. Hydraulic Valves
5. MC-R3 Controller
6. MC-G3 Single Antenna
7. MC-G3 Dual Antenna
8. GPS Vibration Pole
9. Base Station Kit

Dozer Schematic

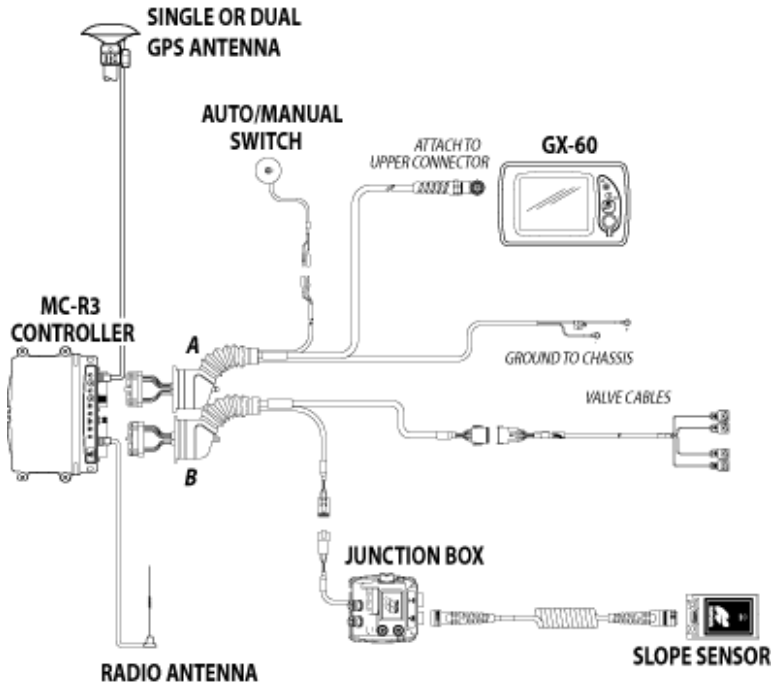

Elevation Control Key



Slope Control Key

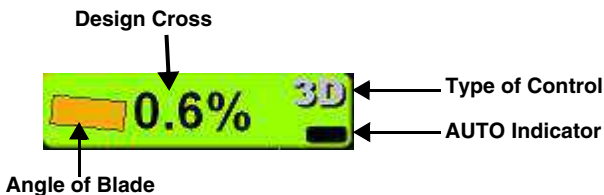

GPS+ Setup and Usage

NOTE: Example of a GPS+ Grader setup.

Creating a Machine Configuration File

1. When the main screen displays, press **Topcon Logo ▶ Control ▶ Machine setup**.



2. Press **New**.



3. Enter the machine information. Press **Next**.

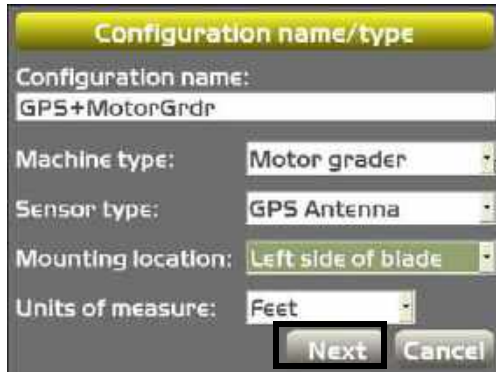

The screenshot shows a dialog box titled "Configuration name/type" with a yellow header. It contains the following fields and options:

- Configuration name: GPS+MotorGrdr
- Machine type: Motor grader
- Sensor type: GPS Antenna
- Mounting location: Left side of blade
- Units of measure: Feet

At the bottom right, there are two buttons: "Next" (highlighted with a black box) and "Cancel".

4. Select **MC-R3** as the **Position Input** and **Control Output**, **MC-R3 standard** as the **Sensor Input**, and press **Next**.



The screenshot shows a dialog box titled "Bulldozer Options" with a yellow header. It contains the following fields and options:

- Position Input : MC-R3
- Control Output : MC-R3
- Sensor Input : MC-R3 standard

At the bottom, there are three buttons: "Back", "Next" (highlighted with a black box), and "Cancel".

5. Select antenna type and enter antenna parameters.
Press **Next**.

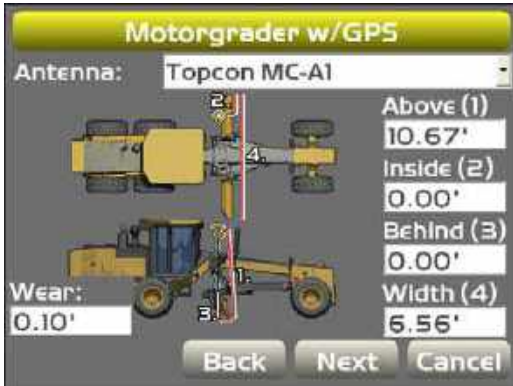

NOTE: You can now enter a “wear” adjustment value that is entered as a positive number but gets subtracted from the overall mast height.

6. Select the GPS precisions for measuring static points. Press **Next**.

GPS Precisions

Max. GPS errors (roving):

Max. Horz. RMS:	0.20'
Max. Vert. RMS:	0.30'

Max. GPS errors (point measurement):

Max. Horz. RMS:	0.10'
Max. Vert. RMS:	0.20'

Back Next Cancel

  +0.400'
 0.000'

Low Precisions...

Position Check

Point: Blade: Left

North	4573.928'
East	10593.218'
Elev	377.672'
Cut to design surface:	0.001'
Alignment station:	2+39.045'
Alignment offset:	-34.274'

Measure... Save Cancel

7. Enter parameters for *GPS Radio Configuration* and press **Next**.

NOTE: The connection will be determined by the type of GPS receiver(s) being used.



GPS Comms Configuration

Connection:

IP Address . . .

Port

 Defaults

Back Next Cancel

8. Select and enter radio information and press **Next**. Refer to the serial number/radio label on the MC-R3 controller to determine the correct radio type. The radio type selection must match the radio contained in the MC-R3.

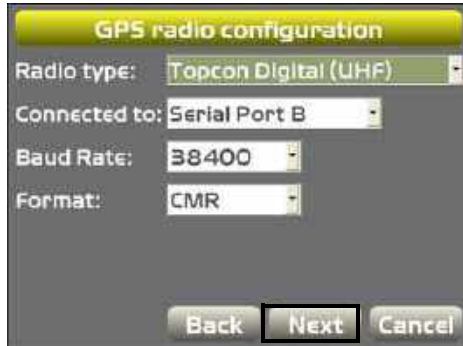

9. If you are using light bars, set LD-40 parameters and press **Next**. See "LD-40 Light Bar Support" on page 6-13 for more details.
10. If no light bars are in use, press **Next** to bypass the LD-40 Setup screen.



11. Press **Finish** to save the machine configuration file.



12. Select a machine configuration file from the *Machine files* dialog box and press **Ok** to set this as the machine for the job.



LD-40 Light Bar Support

To access the LD-40 light bar settings:

1. Press **Topcon Logo ▶ Control ▶ Machine setup**.
The *Machine files* setup dialog box displays.
Cycle through the menu options (press **Next**) until the *LD-40 Setup* dialog box displays.
2. Enter or select the following parameters on the *LD-40 Setup* dialog box.
 - **ID** – select an ID number to identify the LD-40 being setup.
 - **Identify** – press identify to illuminate the light bar selected.
 - **Search** – press to force a search for all LD-40 connections. The serial numbers display in the *ID* field.
 - **Centered** – check mark this box to determine where on-grade will be represented on the LD-40.
 - **Location** – from the drop-down box in this field, select where the LD-40 is located in relationship to the GX-60 control box, either *Left edge*, *Right edge*, *Cut/Fill*, *Slope*, or *Steer Indication*, depending on what machine configuration selected.
 - **Inverted** – check mark this box if the LD-40 is physically inverted when installed.

- Precision – select the LED precision either in 2D or 3D mode.
- Auto – check mark either *Left* or *Right* to enable the LED(s) at the top and bottom of the LD-40 to illuminate when in AUTO mode.

For example: if you select AUTO LEFT, both LED(s) light up on the light bar when the left side is in AUTO.

- 2D – check mark either *Left* or *Right* to enable the LED(s) to operate/display when in either 2D or 3D mode.

It specifies that when in 2D mode, the light bar will work for the left/right side in the same manner as the light bars on the 9168 work in 2D.

- **Colors** – click either the left arrow or the right arrow to invert the color pattern for the LD-40.



Twin Antenna Setup

You can set up a machine configuration to use twin antennas with any machine type. A twin antenna setup will be reflected throughout the process.

To align the twin antennas:

1. Press **Topcon Logo** ▶ **Control** ▶ **Antenna alignment**.



NOTE: The “Antenna alignment” option available only if a twin antenna setup has been selected in the **Machine setup** menu option.

2. Follow the instructions on the *Antenna Alignment* dialog box and press **Ok**.

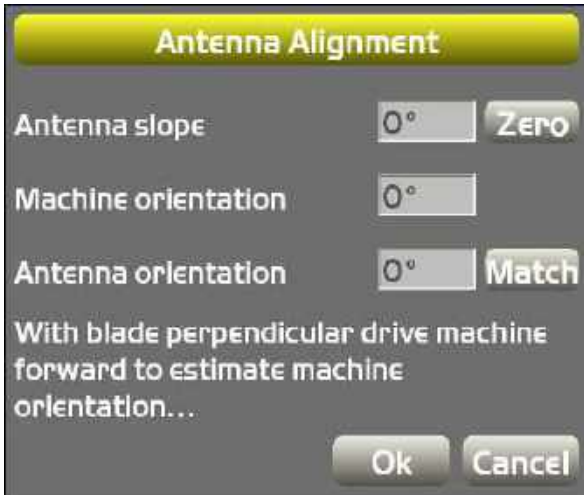

mmGPS+

In addition to standard GPS+ components (Base Station, MC-R3 receiver box), mmGPS applications consists of two primary machine components: the PZL-1 transmitter set up over a point and the PZS MC sensor installed on the machine. A PZS MC sensor on a range pole with a GPS+ receiver provides survey rovers with the same mmGPS functionality as the PZS-MC.

Millimeter GPS (mmGPS) combines the elevation accuracy of a laser with the horizontal and vertical accuracy of GPS+ receivers to provide millimeter accuracy while grading or surveying. The system provides multiple rover support for machine and pole mounted sensors.

NOTE: Except where noted, the File Menu and the Control menu options are the same for all applications.

mmGPS Components

Grader

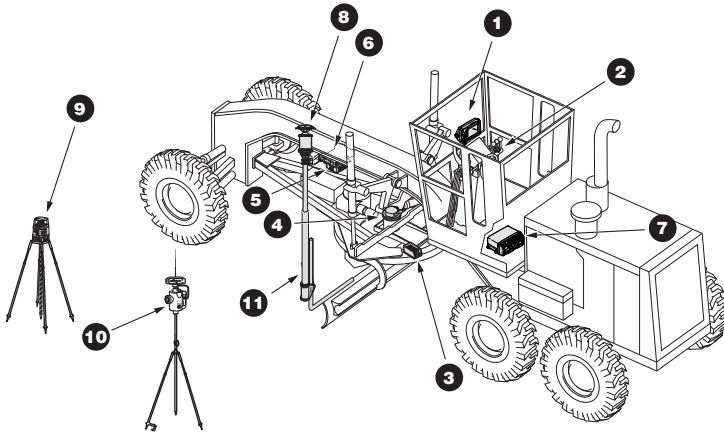

1. GX-60 Control Box
2. Remote Smart Knobs™
3. Blade Slope Sensor
4. Rotation Sensor
5. Mainfall Sensor
6. Hydraulic Manifold Assembly
7. MC-R3 Controller
8. PZS MC Sensor
9. PZL-1 Transmitter
10. PZS-1 with GPS+ Receiver
11. GPS Vibration Pole

Grader Schematic

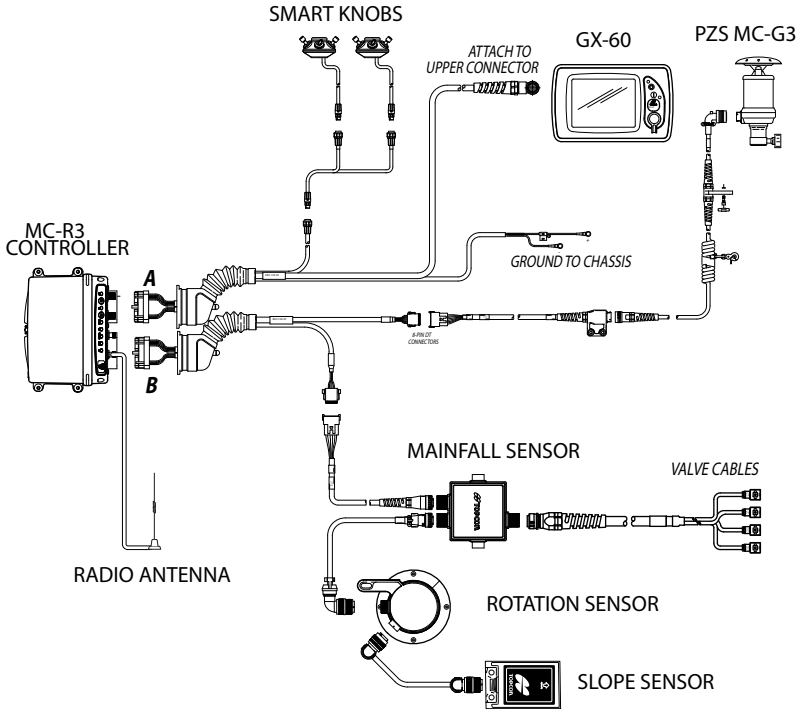

Dozer

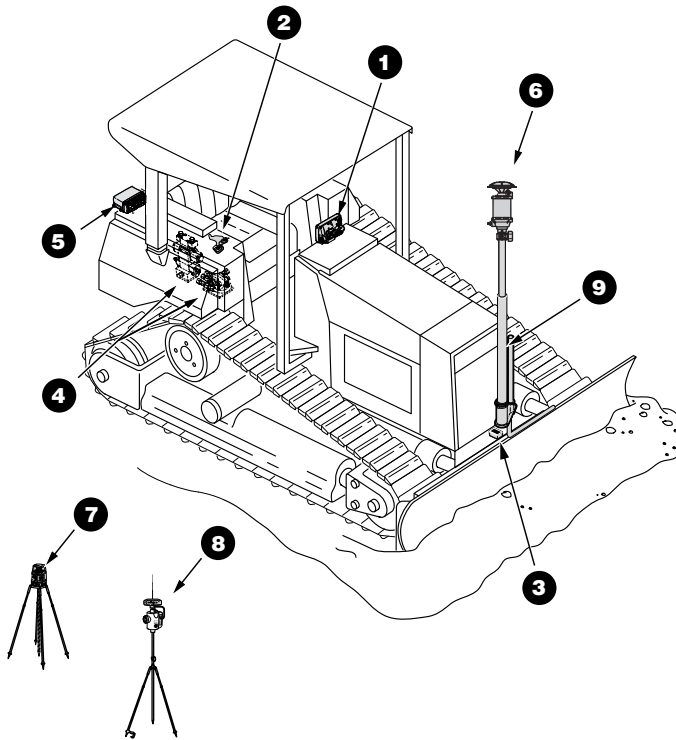

1. GX-60 Control Box
2. Simple Knob
3. Blade Slope Sensor
4. Hydraulic Manifold Assembly
5. MC-R3 Controller
6. PZS MC Sensor
7. PZL-1 Transmitter
8. PZS-1 with GPS+ Receiver

9. GPS Vibration Pole

Dozer Schematic

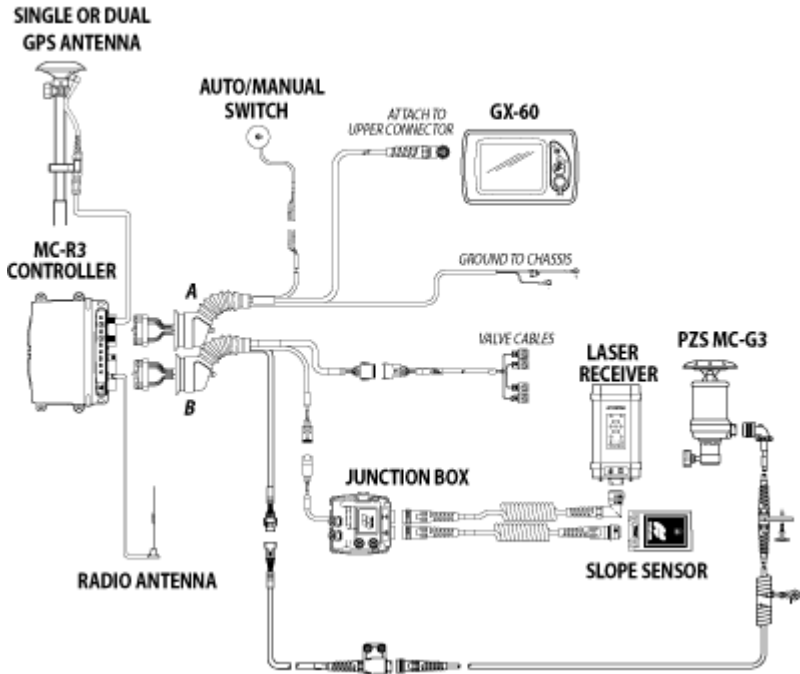

mmGPS 3D Paver Components

The mmGPS 3D Paver system includes various hardware options for controlling mat thickness, including sonic, laser, slope, and mmGPS solutions. The GX-60 control box, in conjunction with 3D-MC software, provides a visual interpretation and on-the-fly control of the jobsite, as well as real-time elevation/slope information.

- MC-R3 Controller/Receiver
- Auto/Manual Switches
- Light Bars (optional)
- 9142 Sonic Tracker
- Paver Junction Box
- Dual Port Slope Sensor
- PZS MC Sensor

Paver Schematic

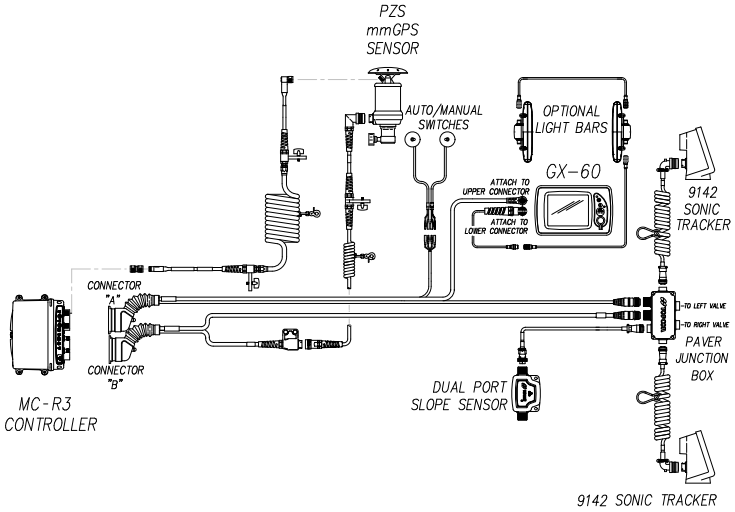

Elevation Control Key



Slope Control Key

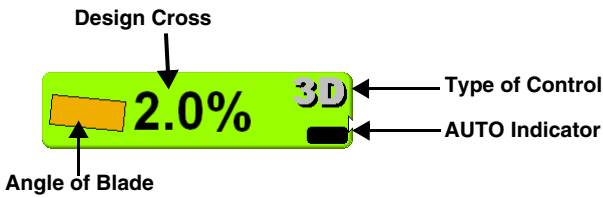

Creating a mmGPS Machine Configuration File

NOTE: Example of a GPS+ Grader Setup

1. When the main screen displays, press **Topcon Logo** ▶ **Control** ▶ **Machine setup**.



2. Press **New**.

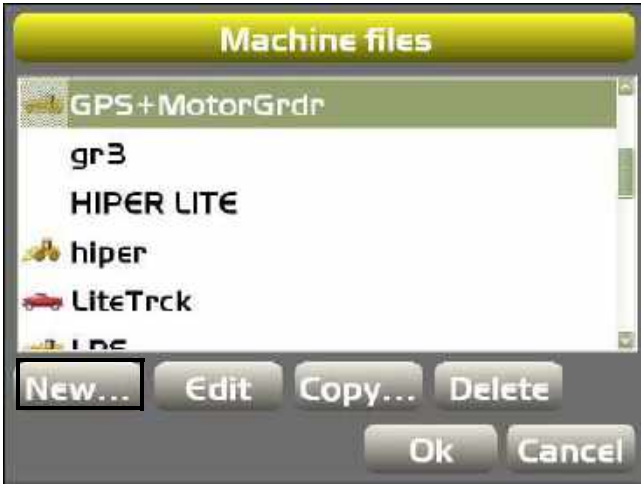

3. Select the machine parameters. Press **Next**.

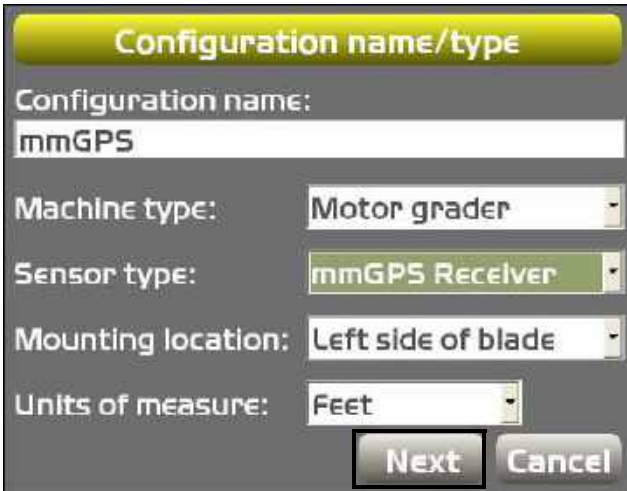

4. Select **MC-R3** as the **Position Input** and **Control Output**, **MC-R3 w/3DMC²** as the **Sensor Input**, and press **Next**.

Bulldozer Options

Position Input : MC-R3

Control Output : MC-R3

Sensor Input : MC-R3 w/3DMC²

Back Next Cancel

5. Select antenna type, enter antenna parameters, and Wear adjustment value, then press **Next**.

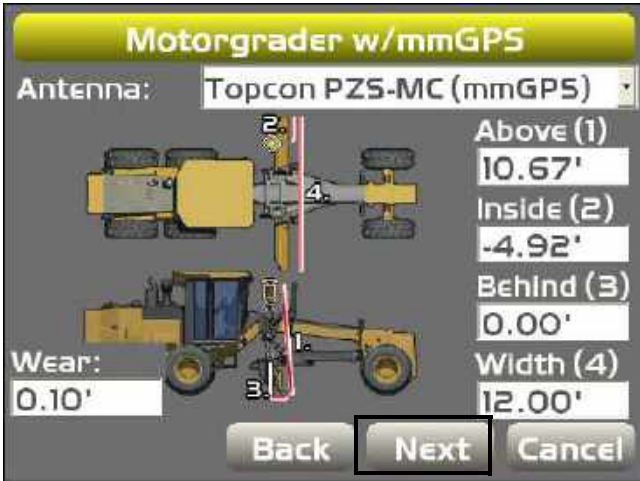

6. Enter GPS precisions for measuring static points.
Press **Next**.

GPS Precisions

Max. GPS errors (roving):

Max. Horz. RMS:	0.20'
Max. Vert. RMS:	0.30'

Max. GPS errors (point measurement):

Max. Horz. RMS:	0.10'
Max. Vert. RMS:	0.20'

Back **Next** Cancel



Low Precisions...

Position Check

Point: Blade, Left

North	4673.928'
East	10593.218'
Elev	377.672'
Cut to design surface:	0.001'
Alignment station:	2+39.045'
Alignment offset:	.34.274'

Measure... Save Cancel

Example of Point Measuring
Screen

7. Enter/select the parameters for *GPS Comms Configuration* and press **Next**.



NOTE: The GPS connection will be determined by the type of GPS receiver(s) being used.

8. Select radio information and press **Next**. Refer to the serial number/radio label on the MC-R3 controller to determine the correct radio type.

NOTE : The radio type selection must match the radio contained in the MC-R3.



GPS radio configuration

Radio type: Topcon Digital (UHF)

Connected to: Serial Port B

Baud Rate: 38400

Format: CMR

Back Next Cancel

9. Select **LaserZone Receiver** parameters and press **Next**.



LaserZone Receiver

GPS port: Serial Port C

Sensitivity: Auto

Channels: All

Advanced...

Back Next Cancel

10. If an LD-40 is being used, select parameters for the LD-40 setup, otherwise, press **Next**.

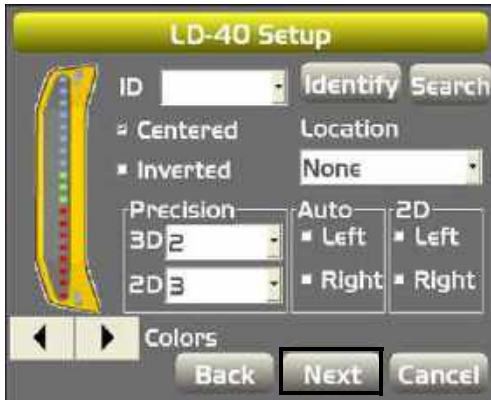

11. Press **Finish** to save the machine configuration file.



NOTE: For additional LD-40 instructions, refer to **LD-40 Light Bar Support** under GPS+ Setup and Usage.

12. Select a machine configuration file on the *Machine files* dialog box and press **Ok** to set this as the machine for the job.



Setting PZL-1 Transmitter Options

1. Press **Topcon Logo** ▶ **Control** ▶ **mmGPS** ▶ **PZL-1 transmitters**.

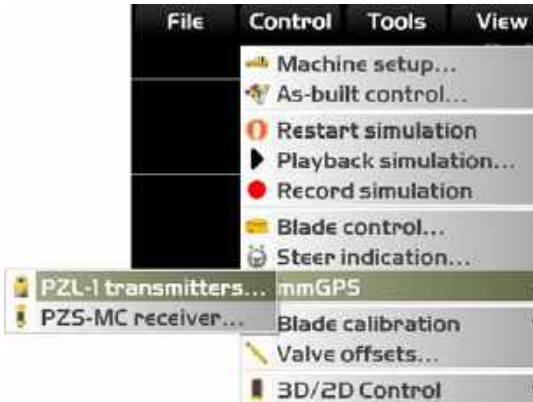

2. Set the PZL-1 transmitter options. Then press **Ok**.

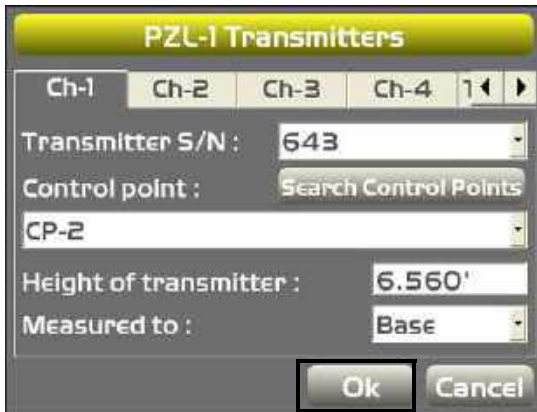

3. On the PZL-1 Transmitters dialog box, you can remove a mmGPS transmitter from the list on the Transmitter tab. Highlight the transmitter to delete, then press **Delete**.
4. Press **Ok** on the confirmation screen to confirm the deletion.

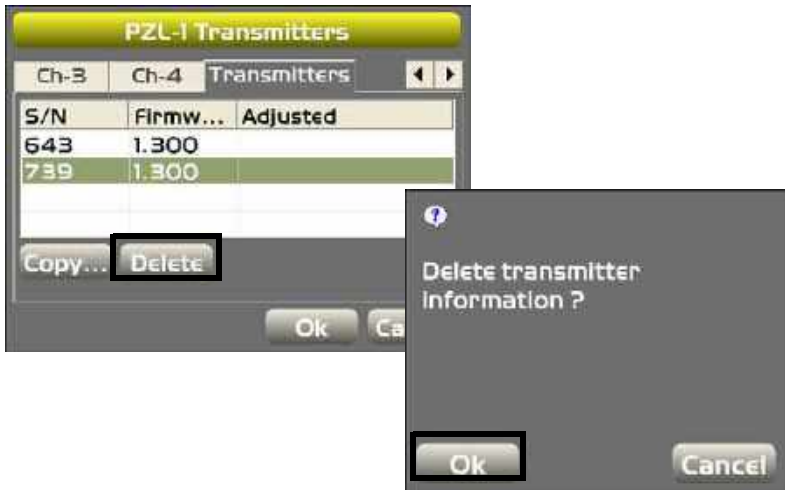

Setting PZS MC Receiver Options

1. Press **Topcon Logo** ▶ **Control** ▶ **mmGPS** ▶ **PZS-MC receiver**

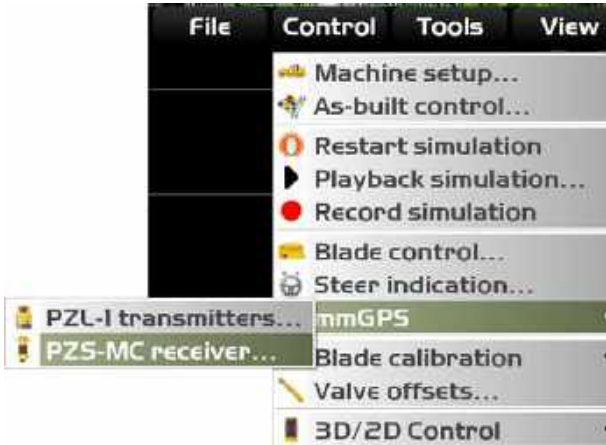

2. Select the PZS-MC parameters. Then press **Ok**.



The image shows a configuration dialog box titled "PZS-MC Receiver". It contains four settings:

- Receiver port : Serial Port C
- Receiver sensitivity : Auto
- Transmitter selection : Any
- Firmware version : eD70

At the bottom, there are three buttons: "Advanced...", "Ok", and "Cancel". The "Ok" button is highlighted with a black border.

3D-MC²

3D-MC² is an addition to the GPS+ system that allows a dozer to run and operate at high speed while maintaining smooth grade.

3D-MC² Components

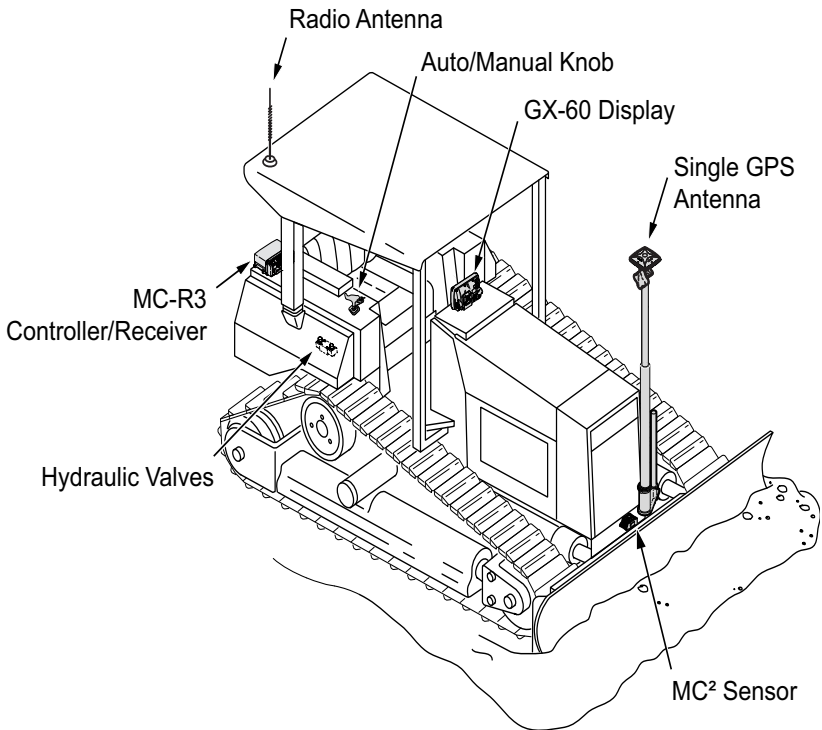

Dozer Schematic

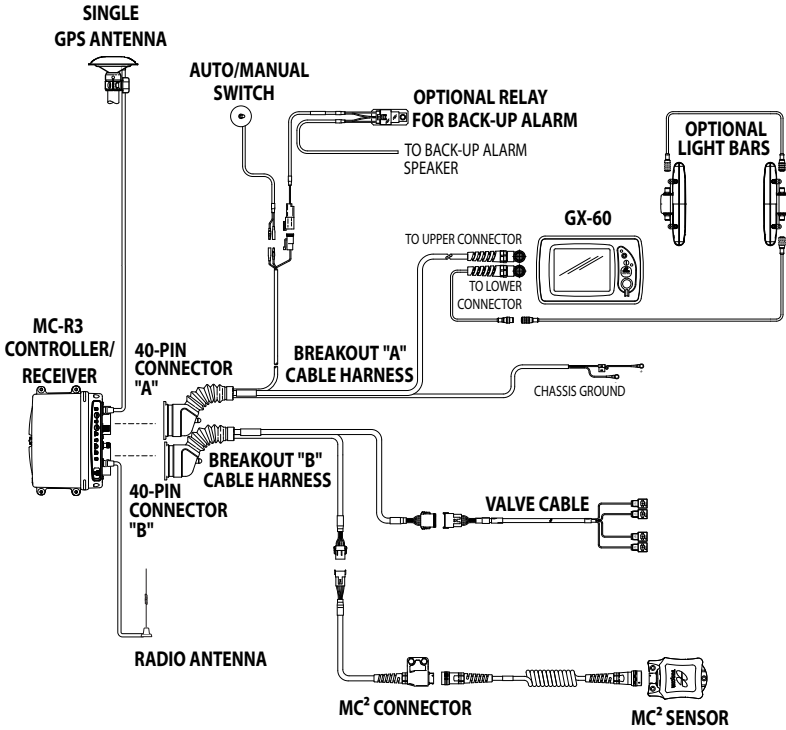

Elevation Control Key

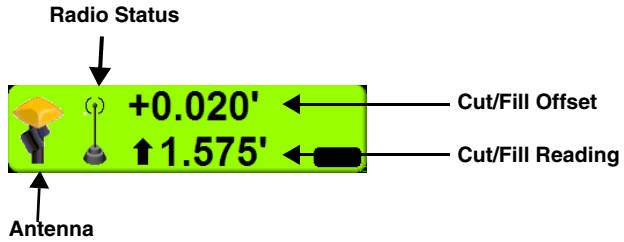

Slope Control Key

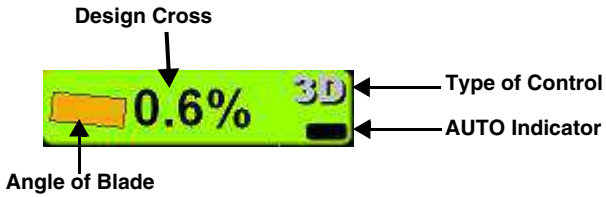

3D-MC² Setup and Usage

Creating a Machine Configuration File

1. Press **Topcon Logo** ▶ **Control** ▶ **Machine setup**.



2. Press **New**.

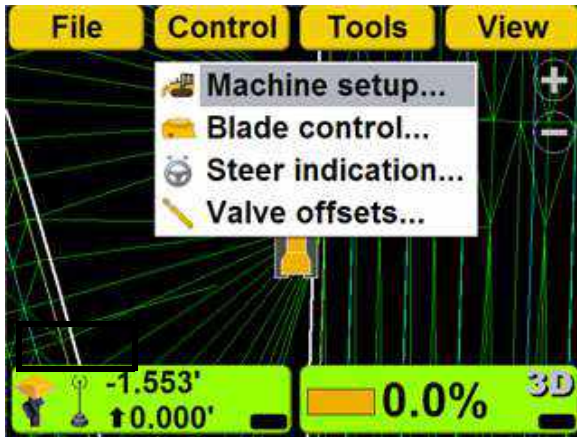

3. Enter the machine parameters. Press **Next**.

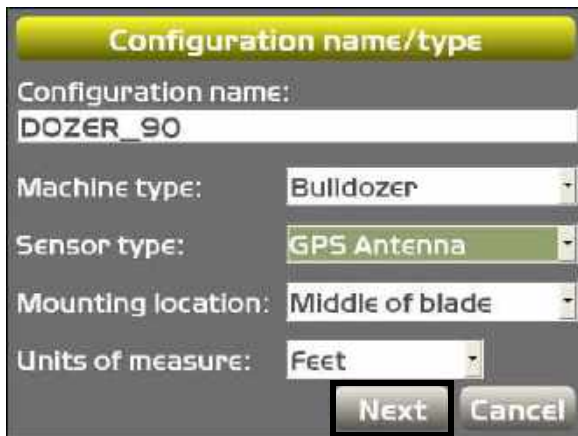
A screenshot of the 'Configuration name/type' dialog box. The title bar is yellow and contains the text 'Configuration name/type'. Below the title bar, there are several input fields and dropdown menus. The first field is 'Configuration name:' with the text 'DOZER_90' entered. The second field is 'Machine type:' with a dropdown menu showing 'Bulldozer'. The third field is 'Sensor type:' with a dropdown menu showing 'GPS Antenna'. The fourth field is 'Mounting location:' with a dropdown menu showing 'Middle of blade'. The fifth field is 'Units of measure:' with a dropdown menu showing 'Feet'. At the bottom right, there are two buttons: 'Next' and 'Cancel'.

4. Select **MC-R3 w/3DMC²** as the **Sensor Input**, and press **Next**.



5. Enter the preferred 3D-MC² parameters and press **Next**. Refer to the **Installation and Calibration Manual** for specific details.

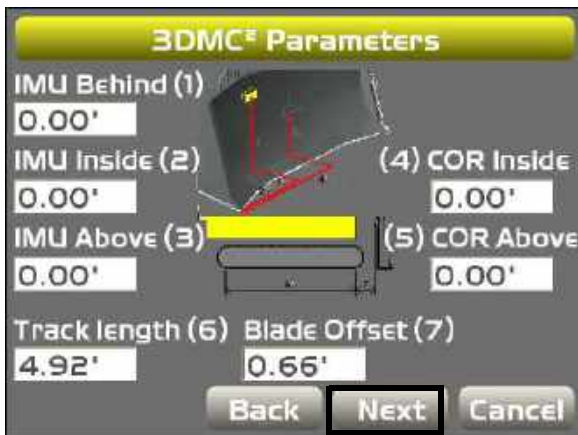

6. Set **Topcon MC-A1** (Single) or **Topcon Twin (MC-A2)** (twin) as the antenna type, enter the antenna measurement parameters, and press **Next**.

Bulldozer w/GPS

Antenna: **Topcon MC-A1**

Wear: **0.00'**

Above (1) **10.41'**

Inside (2) **5.25'**

Behind (3) **0.00'**

Width (4) **6.56'**

Topcon CR-3
Topcon Geodetic III
Topcon Twin (MC-A2)
Topcon MC-A1

Back **Next** Cancel

7. Set **UDP/IP** as the *Connection* type from the drop down menu in the *GPS Comms Configuration* screen. Your MC-R3 controller must have the G₃ 3D-MC² symbol, as shown on the *GPS Comms Configuration* screen, to be compatible with the MC² Sensor. Press **Next**.



8. Enter the GPS precisions for point measurement and roving. Press **Next**.

GPS Precisions

Max. GPS errors (roving):

Max. Horz. RMS:	0.20'
Max. Vert. RMS:	0.30'

Max. GPS errors (point measurement):

Max. Horz. RMS:	0.10'
Max. Vert. RMS:	0.20'

Back Next Cancel



Low Precisions...

Position Check

Point: Blade: Left

North	5143.720'
East	9758.138'
Elev	379.208'
Cut to design surface:	0.000'
Alignment station:	
Alignment offset:	

Measure... Save Cancel

9. Set radio information and press **Next**. Refer to the serial number/radio label on the MC-R3 controller to determine the correct radio type. The radio type selection must match the radio contained in the MC-R3.

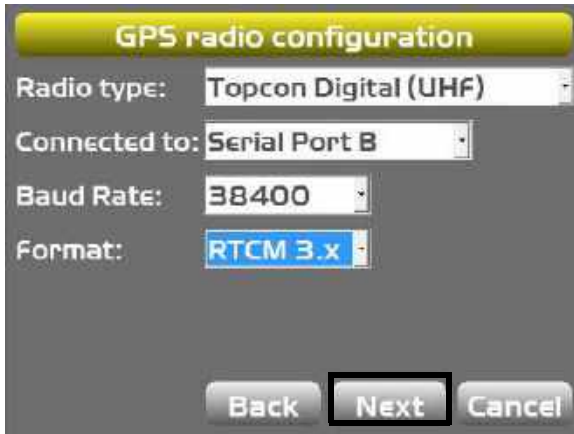

NOTICE: An incorrect radio configuration setting will prevent the machine's radio from connecting with the Base Station. "No radio link" will display on the Elevation Control Key.

10. If using light bars, set LD-40 information and press **Next**. If no light bars are in use, press **Next** to bypass the LD-40 setup.



11. Press **Finish** to save the machine configuration file.



NOTE: For additional LD-40 instructions, refer to **LD-40 Light Bar Support** under “GPS+ Setup and Usage” in Chapter 6.

LPS

The LPS application uses a robotic total station to set the blade to a pre-defined elevation, a “virtual stringline”, that represents the design surface. a 360° prism on the machine is used to measure the blade’s position. The GX-60 then transmits the design information, using a radio to the robotic total station to keep the cutting edge at the correct grade.

LPS Components

Grader

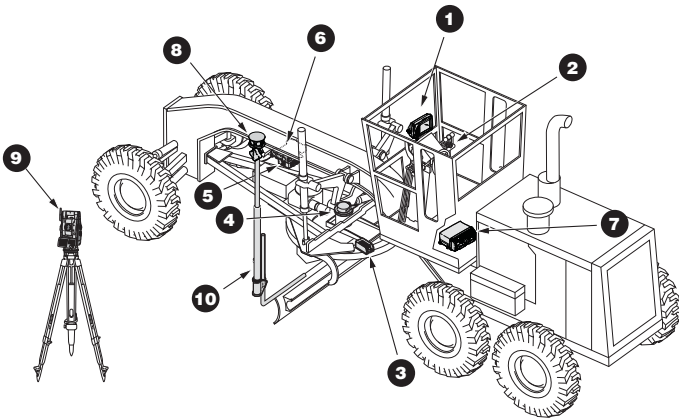

1. GX-60 Control Box
2. Remote Smart Knobs™
3. Blade Slope Sensor

4. Rotation Sensor
5. Mainfall Sensor
6. Hydraulic Manifold Assembly
7. MC-R3 Controller
8. Prism
9. Robotic Total Station
10. GPS Vibration Pole

Grader Schematic

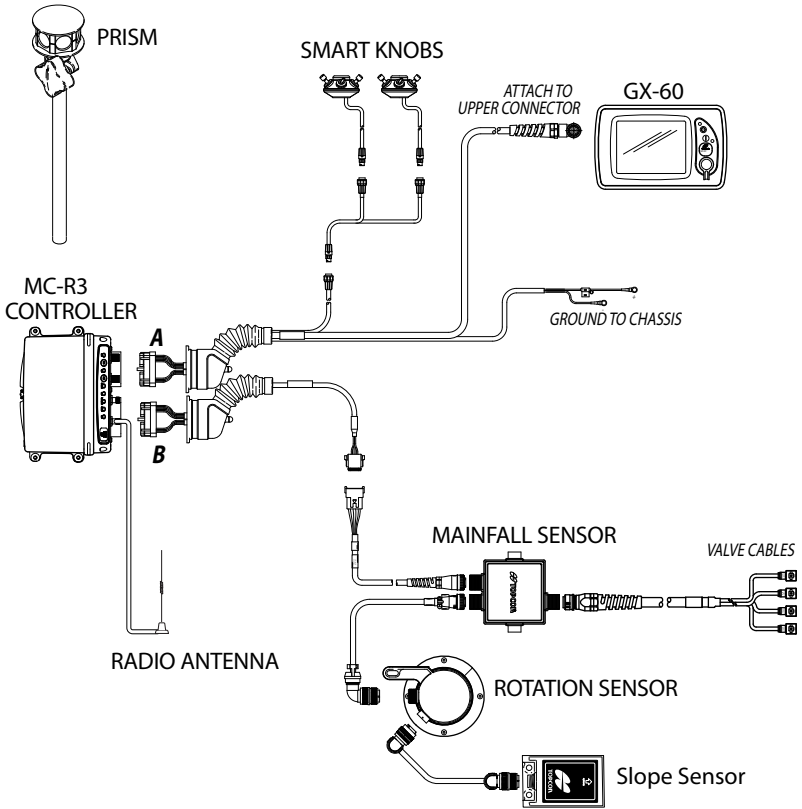

Dozer

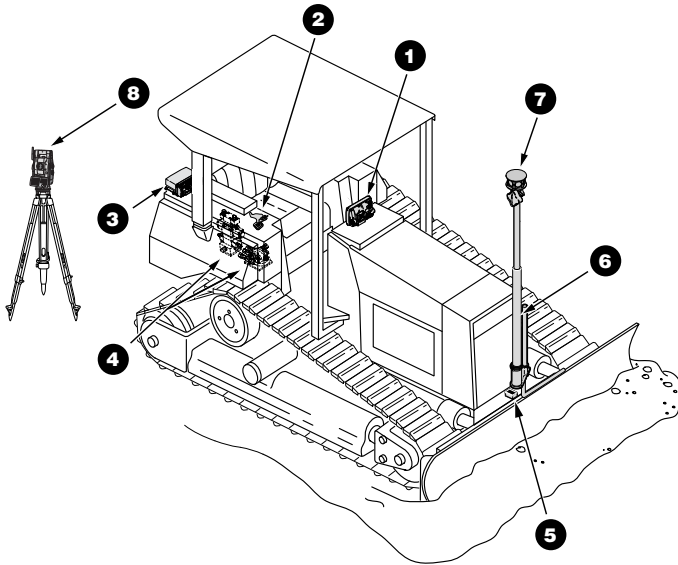

1. GX-60 Control Box
2. Simple Auto/Manual Knob
3. MC-R3 Controller
4. Hydraulic Manifold Assembly
5. Blade Slope Sensor
6. GPS Vibration Pole
7. Prism
9. Robotic Total Station

Dozer Schematic

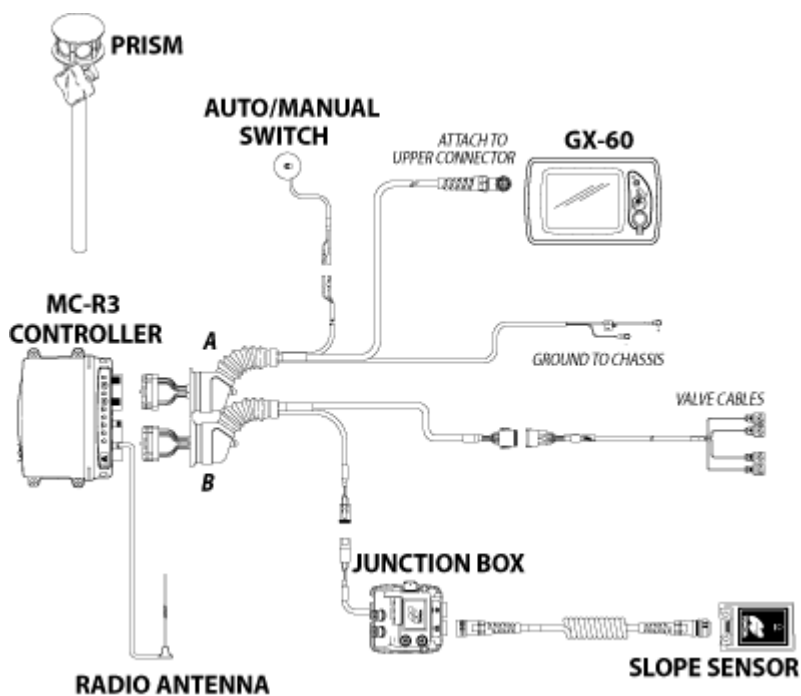

Elevation Control Key



Slope Control Key

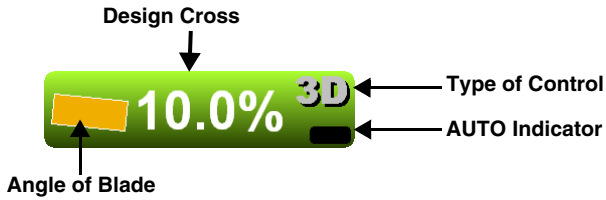

Creating a Machine Configuration File

NOTE: Example of an LPS Motor Grader setup.

1. When the main screen displays, press **Topcon Logo ▶ Control ▶ Machine setup**.



2. Press **New**.

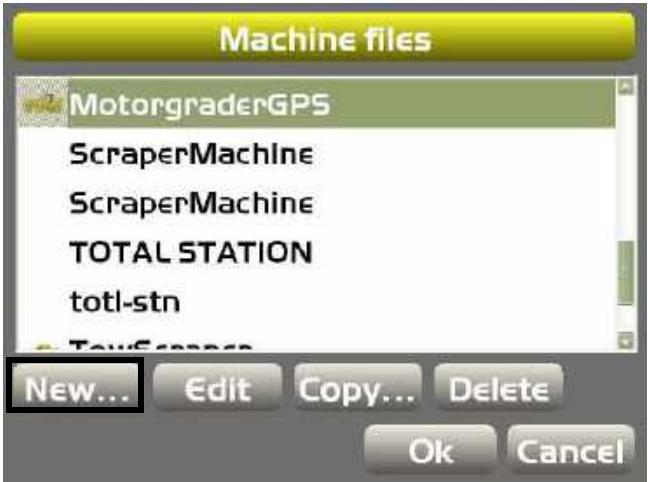

3. Enter the machine information.

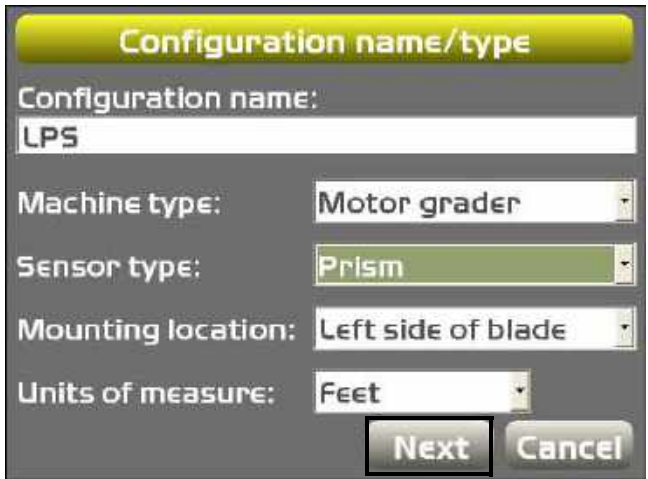

4. Press **Next**.

5. Enter prism information, and press **Next**.

Motorgrader w/LPS

Above (1)
10.75'

Inside (2)
0.00'

Behind (3)
0.00'

Width (4)
6.56'

Wear:
0.49'

Back Next Cancel

6. Enter the information for Left LPS Comms Configuration and press **Next**.

LPS Radio Configuration

Connection: Serial Port

Com Port COM1

Channel: 6

Back Next Cancel

7. Enter or select parameters for the LD-40 light bar and press **Next**.

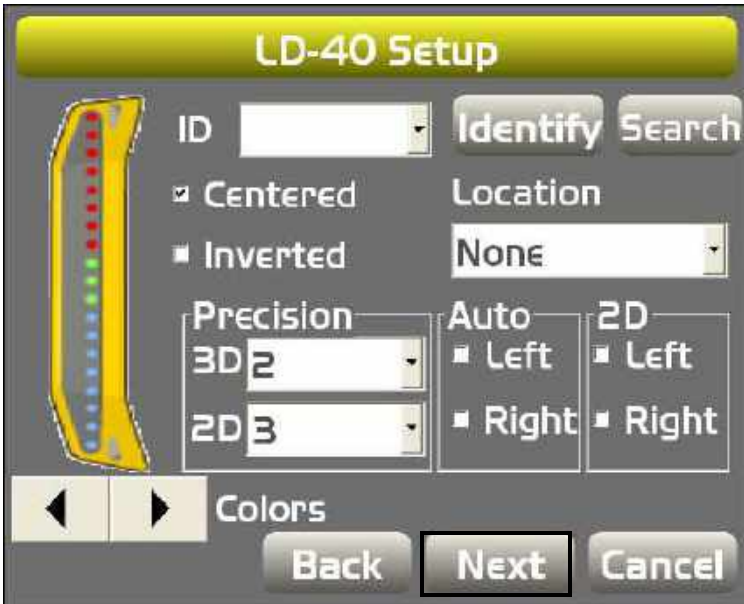

NOTE: For additional LD-40 instructions, refer to **LD-40 Light Bar Support** under GPS+ Setup and Usage.

8. Press **Finish** to save the machine configuration file.

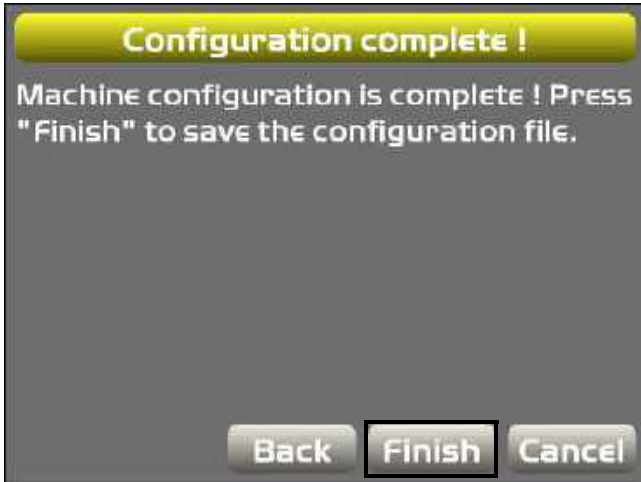

9. Select a machine configuration file on the *Machine files* dialog box and press **Ok** to set this as the machine for the job.

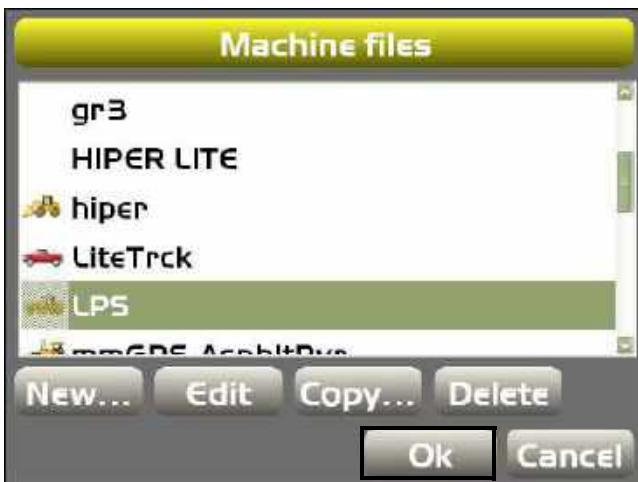

You can now configure the following machines:
Elevating Scraper, Compactor, and Dual Tow Scraper.

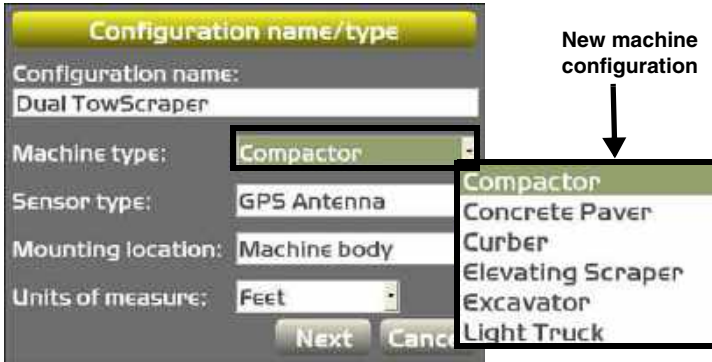

Viewing TS Information

- To view the *TS (Total Station) information* dialog box and tabs, press the **Elevation control** key.



- Press the **TS info** button.

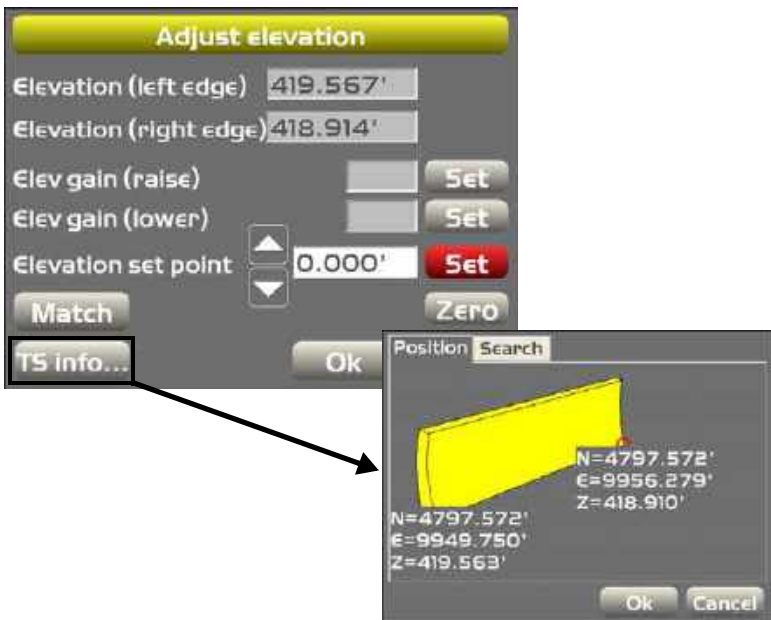

NOTE: Change the elevation gain (raise) by pressing the Elevation gain (raise) **Set** button. The Elevation gain (lower) function only works with the Dozer.

LPS Position Tab

The *Position* tab displays current locations for the left and right sides of the blade. These values are based on the local coordinates, providing quick position and elevation checks at particular points on the project. The “Z” values on this tab match the elevation numbers on the *Adjust elevation* dialog box.

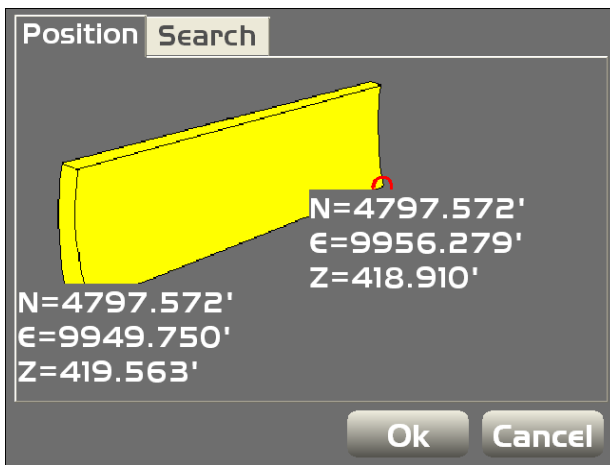

LPS Search Tab



2D

2D control applications consist of either a sonic tracker tracking a feature/string line, or a laser receiver tracking a rotating laser. When 3D-MC is in 2D mode, unnecessary functions are disabled for quick access to 2D-specific functions.

2D Components

Grader

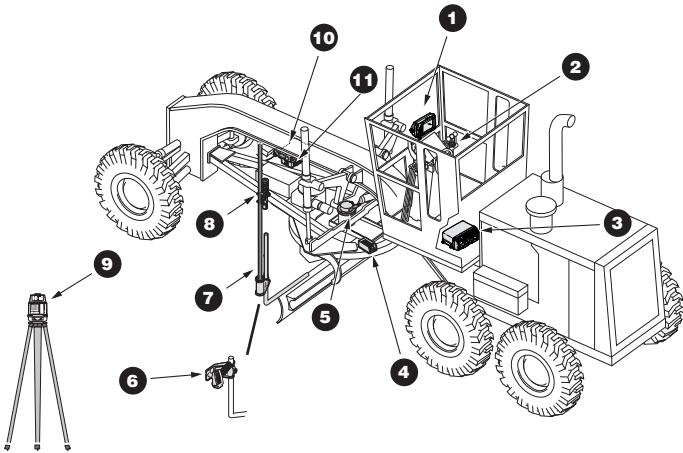

1. GX-60 Control Box
2. Remote Smart Knobs™
3. MC-R3 Controller
4. Blade Slope Sensor

5. Rotation Sensor
6. Sonic Tracker
7. Vibration Pole
8. Tracker Jack
9. Rotating Laser
10. Hydraulic Manifold Assembly
11. Mainfall Sensor

Grader Schematic

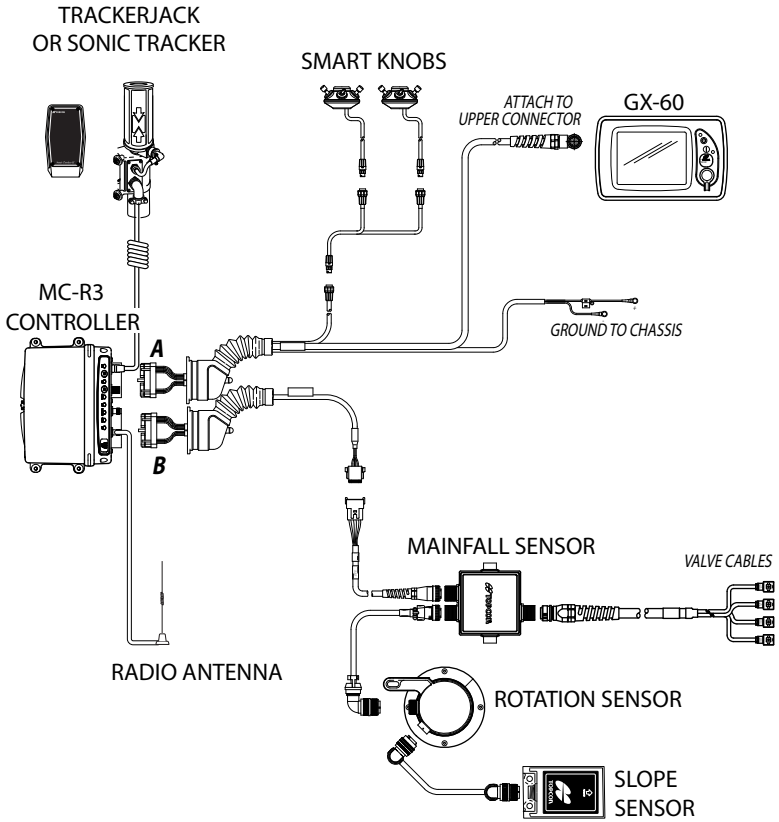

Dozer

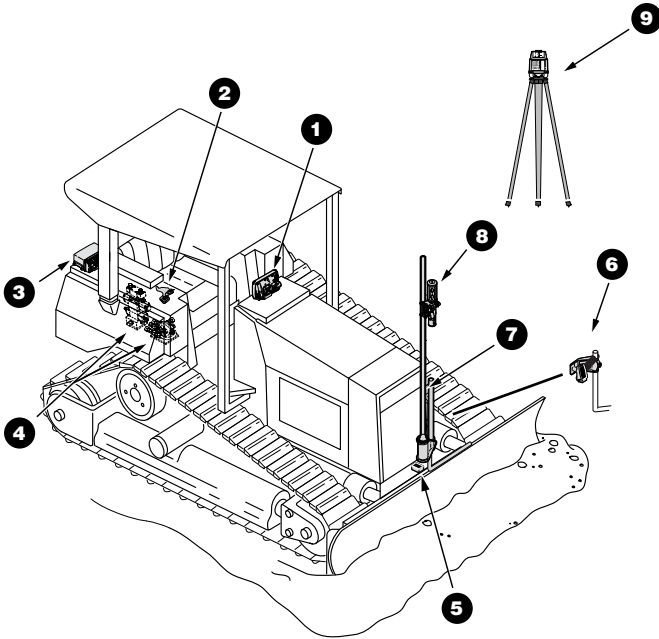

1. GX-60 Control Box
2. Simple Auto/Manual Knob
3. MC-R3 Controller
4. Hydraulic Valves
5. Blade Slope Sensor
6. Sonic Tracker
7. Vibration Pole
8. Tracker Jack
9. Rotating Laser

Dozer Schematic

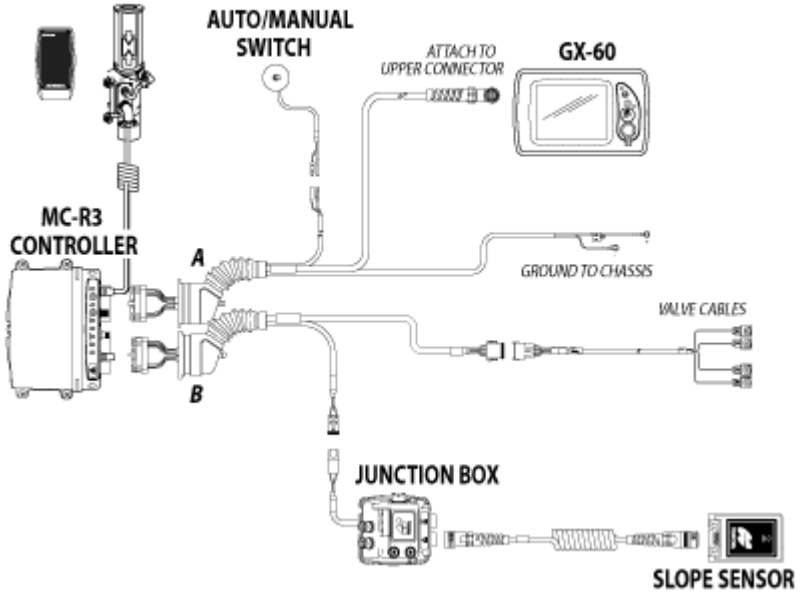

Elevation Control Key

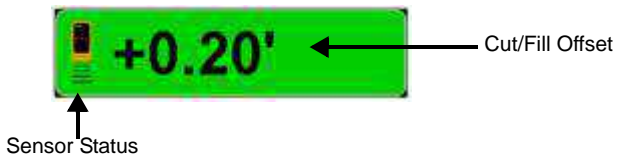

Slope Control Key

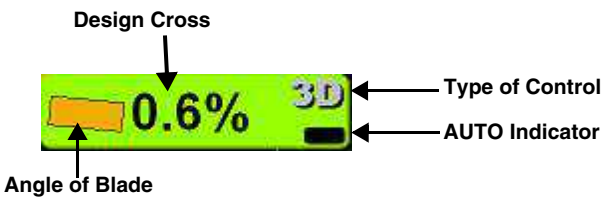

2D Setup and Usage

NOTICE: When using 3D-MC for 2D control applications, only the equipment file is relevant. Other files, settings, and selections have no effect in this mode.

Activating 2D Control

To activate 2D control, press **Topcon Logo** ▶ **Control** ▶ **3D/2D Control** and select the necessary 2D configuration.

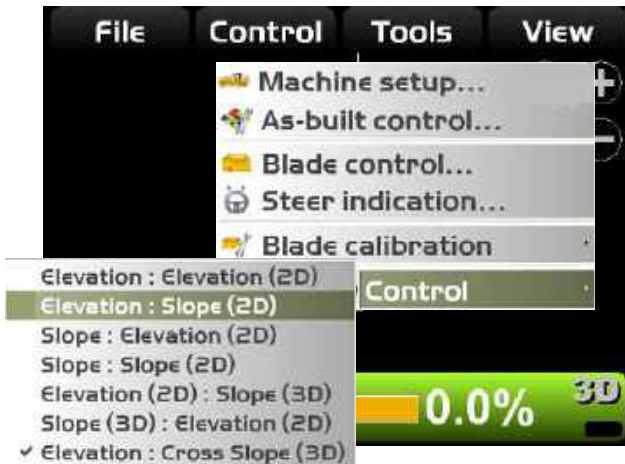

Surveying Grade

The Survey button is used to quickly lock on-grade, performing the same function as the Remote Smart Knobs feature.

Survey the Current Grade:

1. Press the **Elevation Control** key.
2. Press **Survey** to quickly lock on-grade.
3. Press **Ok** to return to the Main Screen.

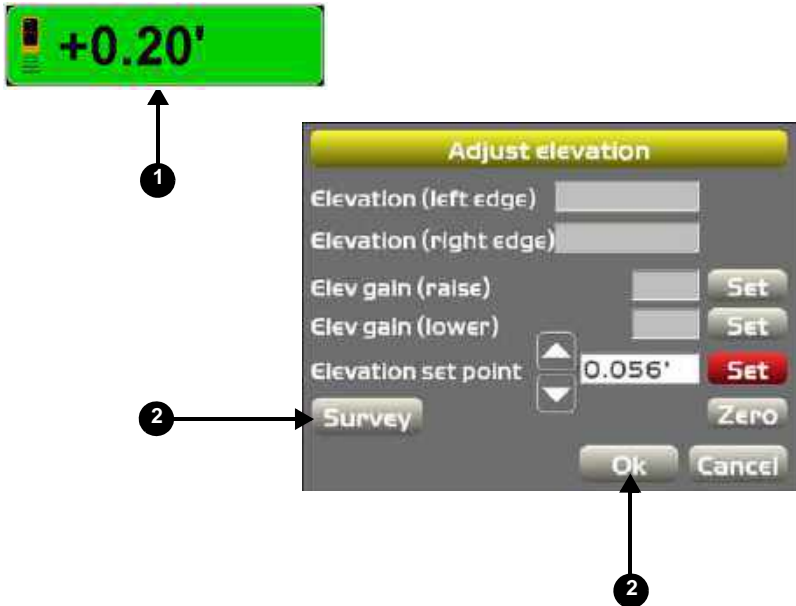

Survey the Current Slope:

1. Press the **Slope Control** key.
2. Press **Survey** to quickly lock on-grade.
3. Press **Ok** to return to the Main Screen.



Excavator

Excavator – X-63/X-63i/X-33

This section describes how to run 3D-MC or 3D-MCi software with excavators using the X-63, X-63i, or X-33 systems. The X-63 system uses TS-1 tilt sensors with two MC-G3 GPS antennas, a radio antenna, a GX-60 Control Box, and an MC-R3 Controller.

The X-63i system uses TS-1 tilt sensors with two PG-S3 GPS antennas, a radio antenna, a GX-60 Control Box, and an MC-i3 GNSS Receiver.

The X-33 system uses TS-i3 tilt sensors, two PG-S3 GPS antennas, a GX-30 Control Box, a radio antenna, and an MC-i3 GNSS receiver.

The TS-1 and TS-i3 tilt sensors measure the pitch angle of various machine elements. Each sensor accurately measures a gravity referenced angle of the body, boom, stick, and bucket, sending this angle data to the GX-60 (or GX-30 for X-33 systems) to provide precise grade. Each sensor is configured and calibrated for its specific location on the excavator.

X-63 Components

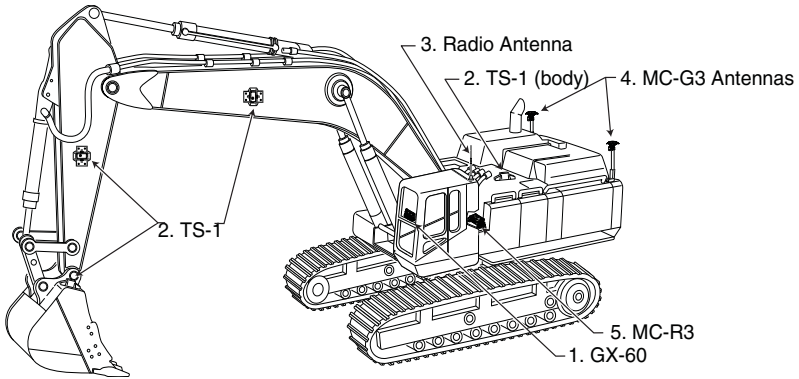

1. GX-60 Control Box
2. TS-1 Tilt Sensors
3. Radio Antenna
4. MC-G3 Machine Antennas (2)
5. MC-R3 Controller
6. Base Station Kit (not pictured)

X-63i Components

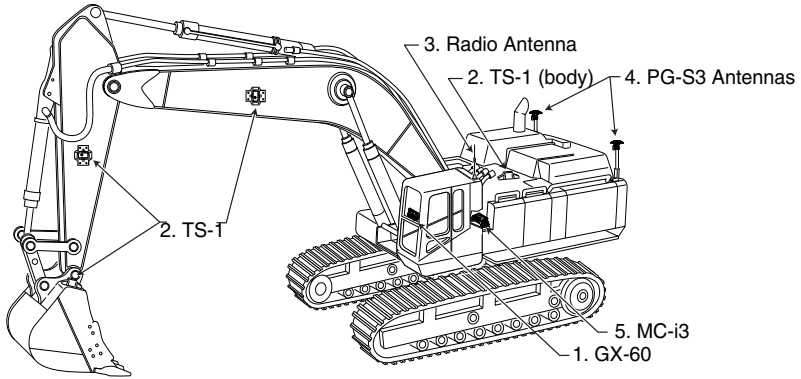

1. GX-60 Control Box
2. TS-1 Tilt Sensors
3. Radio Antenna
4. PG-S3 Machine Antennas (2)
5. MC-i3 GNSS Receiver
6. Base Station Kit (not pictured)

X-33 Components

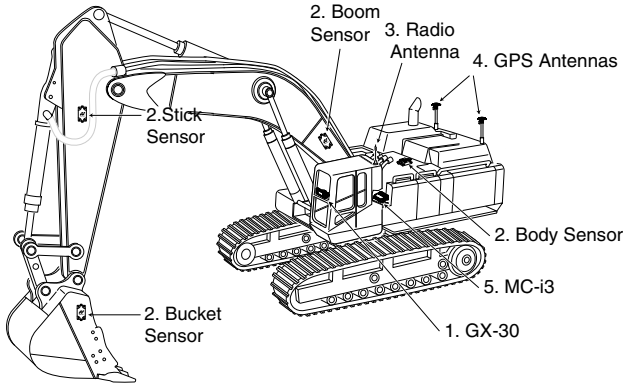

1. GX-30 Control Box
2. TS-i3 Tilt Sensors
3. Radio Antenna
4. PG-S3 GPS Antennas (2)
5. MC-i3 GNSS Receiver

Elevation Control Key

The Elevation Control key displays cut/fill readings and the cut/fill offsets for the elevation of the blade. The key also indicates the status of the connected sensor with graphics, informational messages, and colors.

When pressing the Elevation Control key, the *Adjust elevation* dialog box displays, containing elevation information and elevation configuration functions.

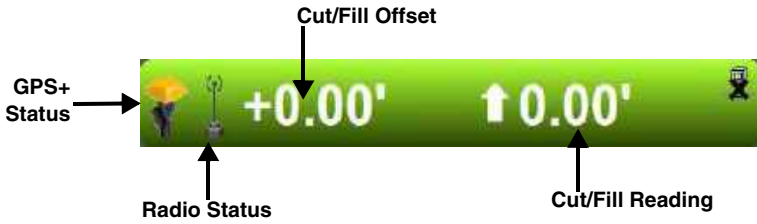

Adjust Elevation

To display the *Adjust elevation* dialog box, press the **Elevation Control Key**. The *Adjust elevation* dialog box displays the following information and settings:

- Elevation (left edge) – displays the elevation of the left edge of the bucket based on local site coordinates.
- Elevation (right edge) – displays the elevation of the right edge of the bucket based on local site coordinates.

- Elevation set point – displays the current cut/fill offset, or amount of additional height applied to the Design Surface.
- Match – sets the current Design Surface to the elevation of the cutting edge, changing the cut/fill reading to zero. The cut/fill Offset number then displays the distance from the new, matched grade to the original Design Surface. This key allows you to quickly adjust the grade to a more manageable cut or fill.
- Zero – sets the elevation set point value to zero.
- GPS info – displays the GPS information dialog box. For dual GPS systems, a second GPS info button is shown for the auxiliary board.

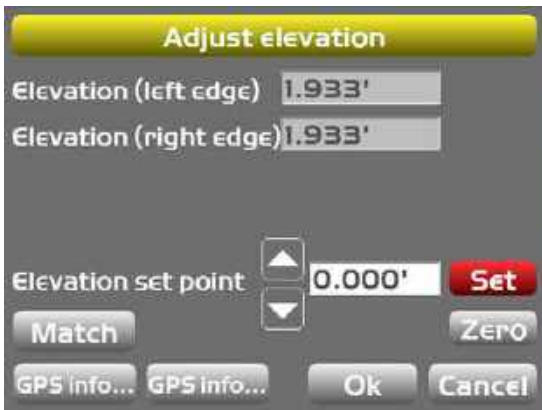

NOTE: MC-i3 systems with either FH915+ or Digital UHF 2 radio boards will not have a second GPS info button.

X-63/X-63i/X-33 Machine Setup

Refer to the **X-63/X-63i/X-62/X-33/X-32 Installation and Calibration Manual** for machine setup and calibration.

NOTE: When facing forward, the Main antenna is on the left of the machine, or on the side behind the cab. Also, the X-63i will have a different antenna mount than the X-63 and X-33.

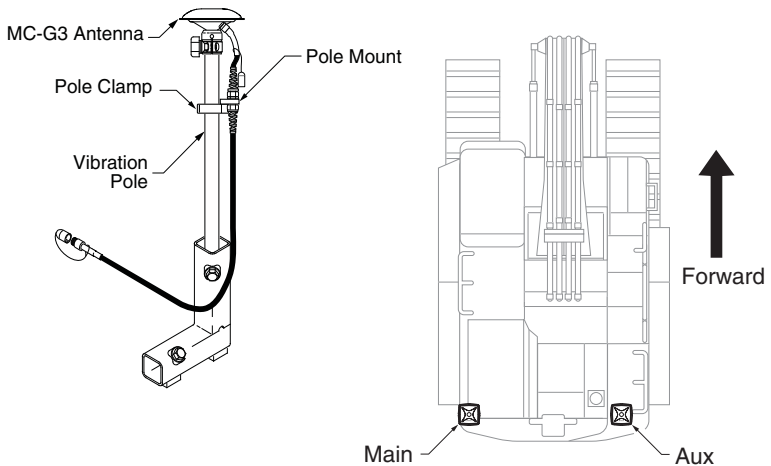

Machine Radio Antenna Setup

The machine radio antenna is attached to the machine's roof using a magnetic mount, and generally stays on the machine. The antenna should be

positioned vertically and as high as possible on the machine to maximize signal reception.

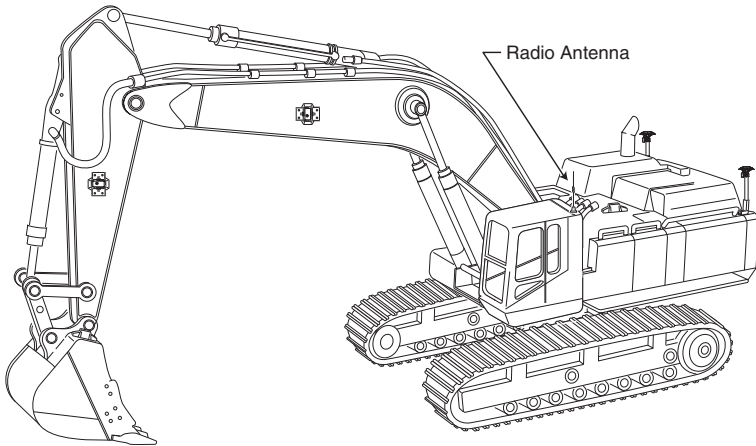

MC-R3 Controller Box Setup (X-63)

The MC-R3 Controller Box is designed for quick installation at the beginning of the day and quick removal at the end of the day.

1. Place the MC-R3 Controller Box in a suitable location (in the cab) where all four magnets attach to the machine. The LED lights should be visible to the operator, and all ports should be accessible to connect the cables.
2. Attach the following cables to the MC-R3 Controller Box:
 - Breakout A cable
 - GPS Main Antenna cable

- GPS Auxiliary Antenna cable
- Radio Antenna cable

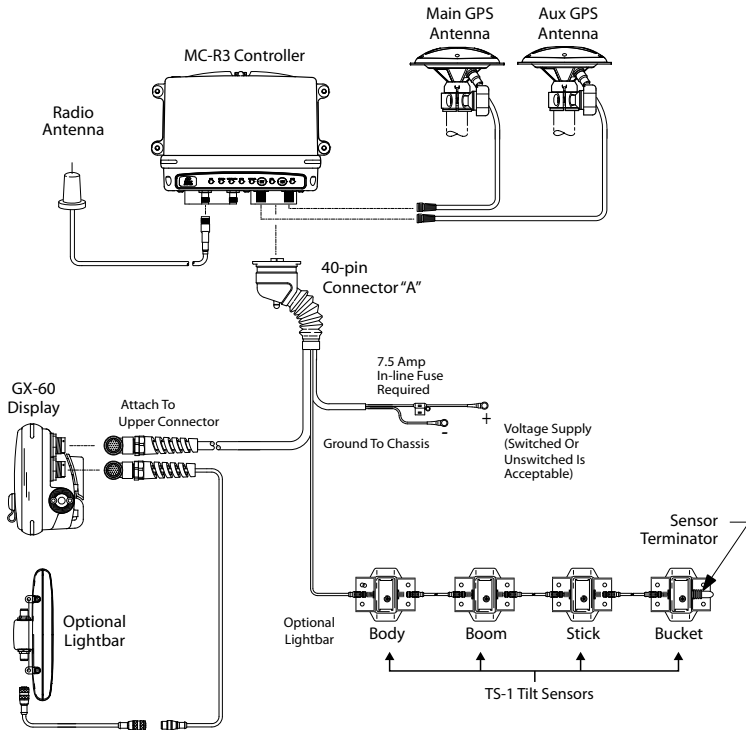

Figure 11-1. X-63 Cable Connections

MC-i3 GNSS Receiver Setup (X-63i/X-33)

The MC-i3 GNSS Receiver is designed for quick installation at the beginning of the day and quick removal at the end of the day.

1. Place the MC-i3 GNSS receiver in a suitable location (in the cab) where all four magnets attach to the machine. The LED lights should be visible to the operator, and all ports should be accessible to connect the cables.
2. Using the included adapters, attach the following cables to the MC-i3 GNSS receiver:
 - The PG-S3 Antenna yellow cable to the Main GPS Antenna port, the black cable to the Aux GPS Antenna port
 - The Rover Radio Antenna cable to Radio Antenna port
 - Power cable

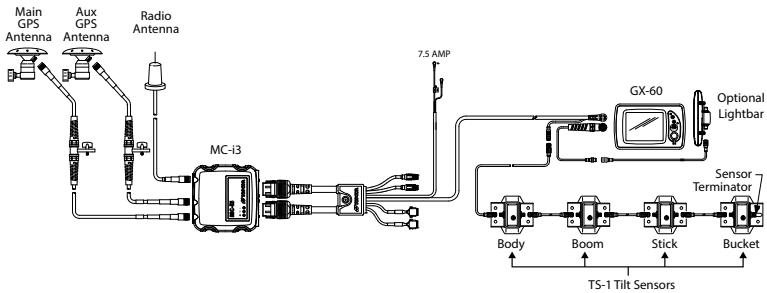

Figure 11-2. X-63i Cable Connections

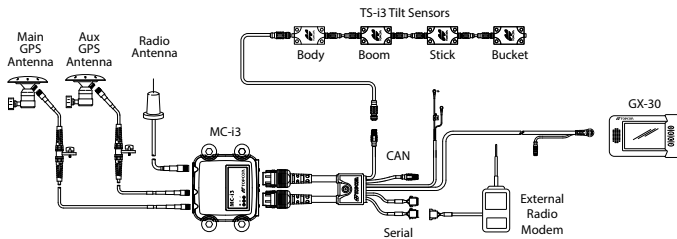

Figure 11-3. X-33 Cable Connections

Creating an X-63/X-63i/X-33 Machine Configuration File

The machine configuration file provides vital information about the type of machine, the setup of the components on the machine, machine measurements, and radio configuration information.

NOTICE: You must have a machine configuration file before beginning to grade.

1. On the main screen, press **Topcon Logo** ▶ **Control** ▶ **Machine setup** to display the *Machine files* screen.

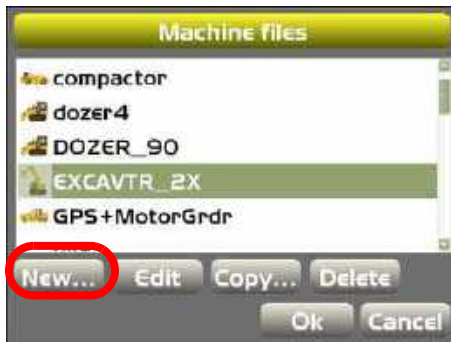

2. Press **New** to begin creating a machine configuration file.
3. On the *Configuration name/type* screen, enter the following information and press **Next**:
 - Configuration name – enter a name for the machine configuration on the alphanumeric pop-up keyboard and press **Ok**.
 - Sensor – select either *GPS Antenna, 2D*, or *GPS and 2D*.
 - Location – only *Machine Body* is available.

- Units of measure – select the unit of measure (*Meters, Feet, Inches, Centimeters, or Feet + Inches*).

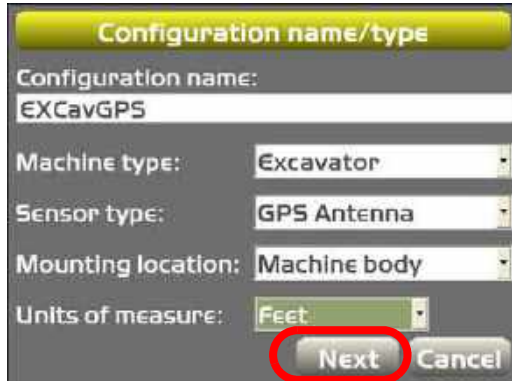

Configuration name/type

Configuration name: EXCavGPS

Machine type: Excavator

Sensor type: GPS Antenna

Mounting location: Machine body

Units of measure: Feet

Next Cancel

4. For systems using an MC-R3, select **MC-R3** for Position Input and **GX-60** for Sensor Input, and press **Next**.

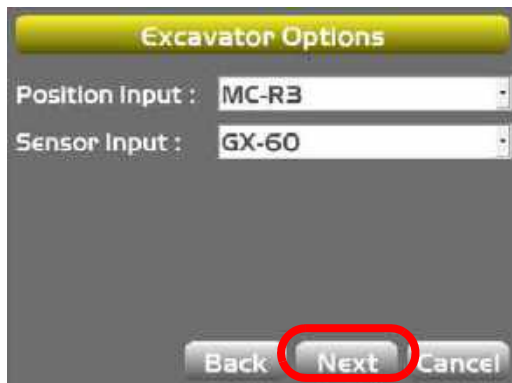

Excavator Options

Position Input : MC-R3

Sensor Input : GX-60

Back Next Cancel

5. For systems using an MC-i3, select either **MC-i3 (SITELINK)** or **MC-i3 (UHF/SS)** for Position Input and **GX-60** for Sensor Input, and press **Next**.

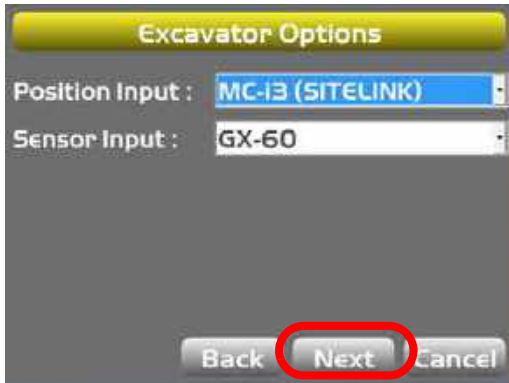

NOTE: Some older equipment may require an alternative setup. See “MC-R3/MC-i3 Configurations” on page A-25 for other configurations.

NOTICE: Incorrect measurements or data entry errors have a direct affect on grading accuracy. Take each measurement twice to ensure accuracy.

6. On the *Antenna Positions (Mounting)* screen, enter your machine's measurements and press **Next**.



7. On the *Excavator Antenna Heights* screen, enter your machine's measurements and press **Next**.

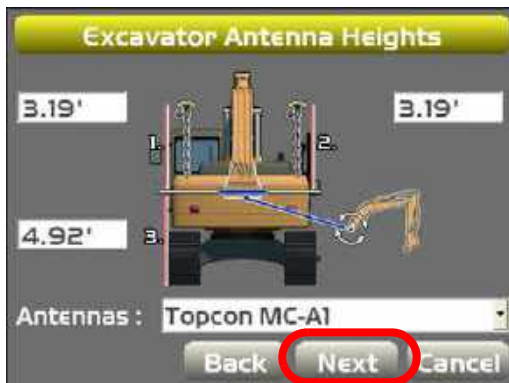

8. On the *Excavator Frame/Sensors* screen, enter the appropriate information for your machine and press **Next**.

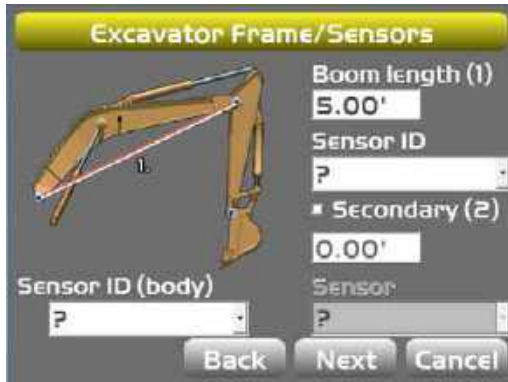

9. On the *Excavator Stick* screen, enter the appropriate information for your machine and press **Next**.



10. On the **Bucket Sensor Mounting** screen, select the appropriate Sensor ID (bucket), and use the check boxes for dog-bone mounting or inverted bucket if applicable; press **Next**.

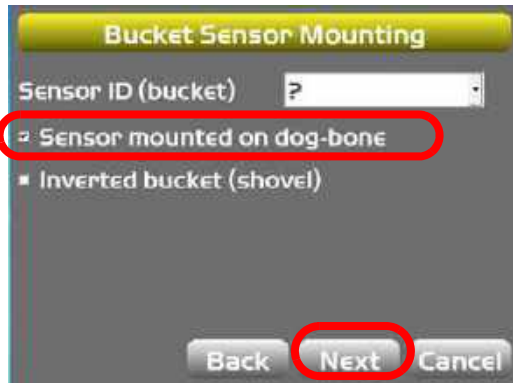

11. If dog-bone mounting has been checked, the **Excavator DogBone** screen will appear. Enter the appropriate measurements for your machine and press **Next**.



NOTE: If the dog-bone sensor option is not checked, this screen will not appear.

Once you have setup the sensors for your machine, you can choose to create/calibrate a new bucket, or edit/calibrate an existing bucket.

12. On the *Excavator Buckets* screen press **New** to create/calibrate a new bucket, or select an existing bucket and press **Edit**.

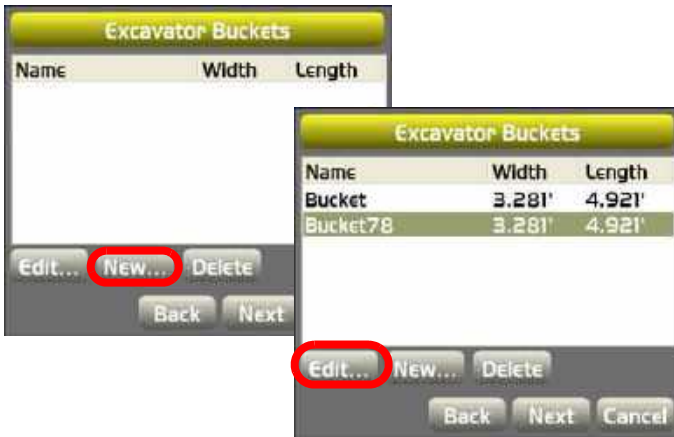

13. On the *Excavator Bucket Setup* screen, enter the appropriate information for your machine and press **Next**. If using a tilt bucket, check the Tilt bucket

check box, enter the appropriate information, and press **Next**.

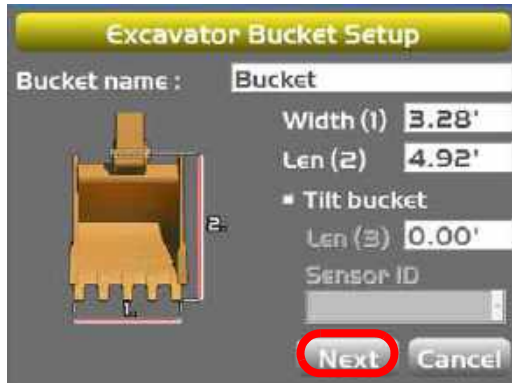

14. When calibrating, position the bucket to be plumb from pivot pin to the bucket teeth, and press **Calibrate**. To continue to the next screen, press **Next**.

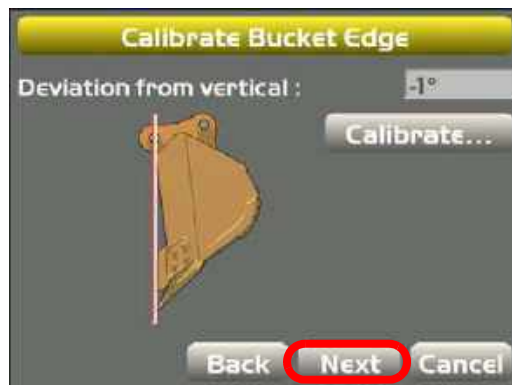

15. When calibrating, position the bottom of the bucket to be flat on the ground and press **Calibrate**. To continue to the next screen, press **Finish**.

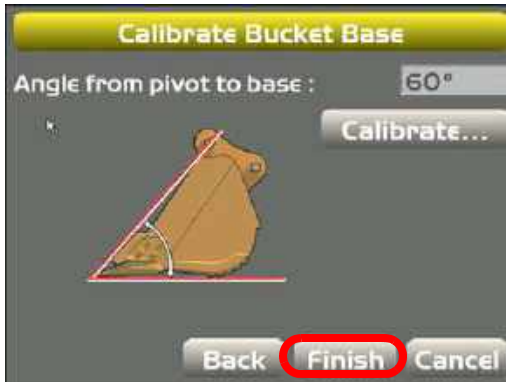

16. On the *Excavator Buckets* screen, press **New** to add more buckets, or press **Next** to continue.



17. If you chose **2D** or **GPS and 2D** as part of the sensor setup in step 3, enter the appropriate

information for your machine at the *LSB10W* screen and press **Next**; otherwise, skip to step 18.



18. On the *GPS Precisions* screen, enter the appropriate information for your machine and press **Next**.

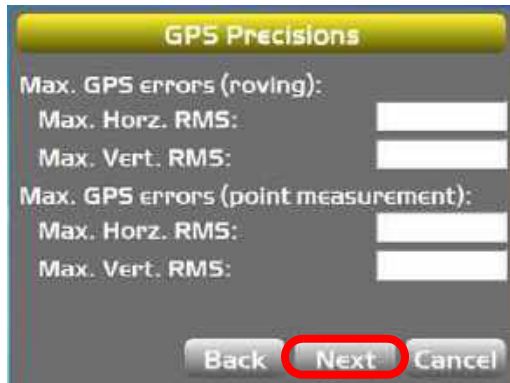

19. On the *GPS radio configuration* screen, select the radio type of the MC-R3/MC-i3 box, the serial port

the radio is connected to (usually Port B), the Baud Rate, and the Format. Press **Next**.

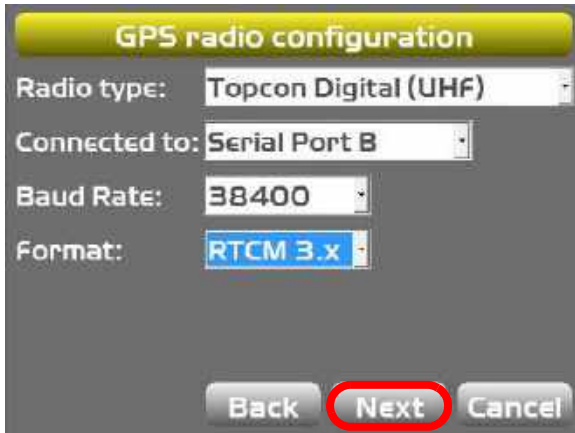

20.If using light bars, set the LD-40 information and press **Next**. If no light bars are in use, press **Next** to bypass the LD-40 setup parameters.



NOTE: For additional LD-40 instructions, see “LD-40 Light Bar Support” on page 6-13.

21. On the *Configuration Complete!* screen, press **Finish** to save the configuration.

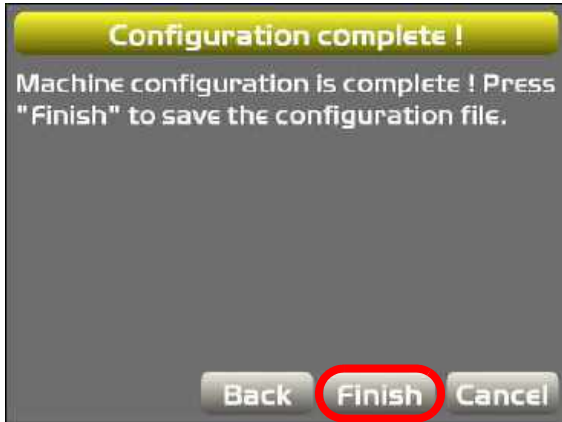

CAUTION: You must press Finish to save the file. Failure to do so will result in losing all entered information.

TIP: A simple check ensures that the machine receives corrections from the Base station: if the Elevation Control Key is green, the system is ready. If the key is red or a status icon is crossed out, check machine cable connections.

Excavator – X-62/X-32

This section describes the procedures necessary to run 3D-MC software in 2D mode for an X-62 system using TS-1 sensors with a LS-B10W laser receiver, and X-32 systems using TS-i3 sensors and a compass.

The tilt sensors measure the pitch angle of various machine elements. Each sensor accurately measures a gravity referenced angle of the body, boom, stick and bucket, sending this angle data to the GX-60 (or GX-30 for X-32 systems) to provide precise grade. Each sensor is configured and calibrated for its specific location on the excavator.

The LS-B10W Laser Receiver adds a laser height reference to the X-62 system. The LS-B10W is calibrated for its location on the stick of the excavator.

NOTE: Refer to the **X-63/X-63i/X-62/X-33/X-32 Installation and Calibration Manual** for more information on installing and calibrating the X-62 and X-32 systems.

The center point of rotation of the cab is used as a reference point in the X-62 and X-32. All calculations are made from this center point and end at the bucket teeth.

NOTE: During operation, the system does not take machine rotation into account. Avoid rotation of the machine for accurate work.

X-62 Components

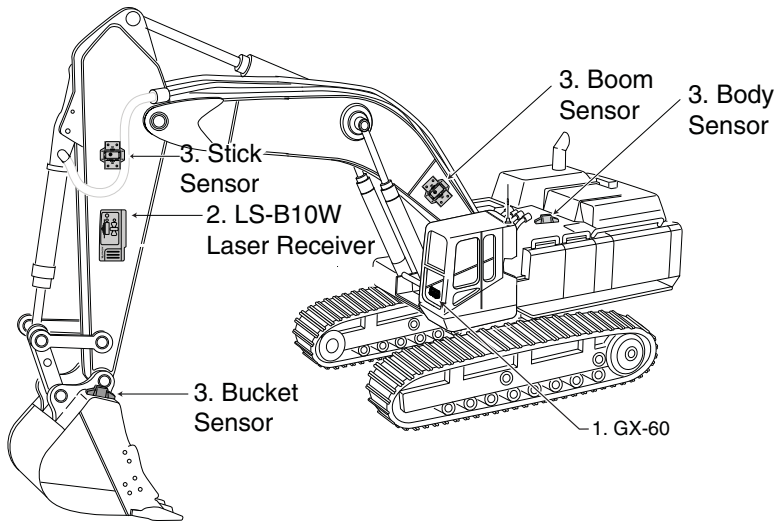

1. GX-60 Control Box
2. LS-B10W Laser Receiver and Bracket
3. TS-1 Sensors (Body, Boom, Stick, and Bucket/Dogbone)

X-62 Schematic

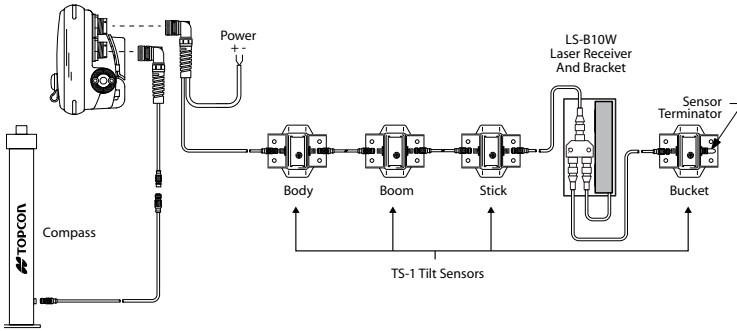
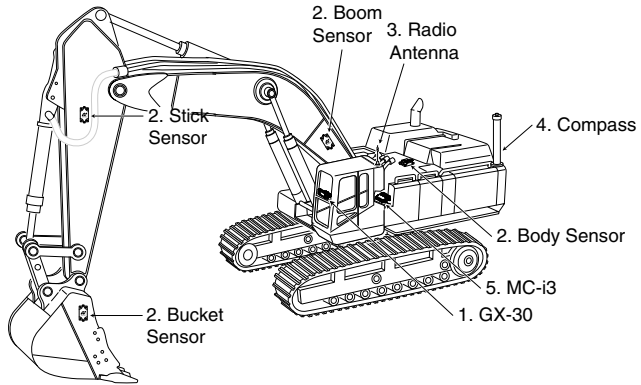

Figure 11-4. X-62 Cable Connections

X-32 Components



1. GX-30 Control Box
2. TS-i3 Tilt Sensors
3. Radio Antenna
4. Compass
5. MC-i3 GNSS Receiver

X-32 Schematic

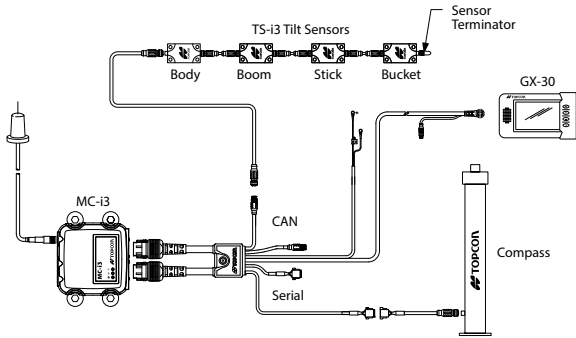
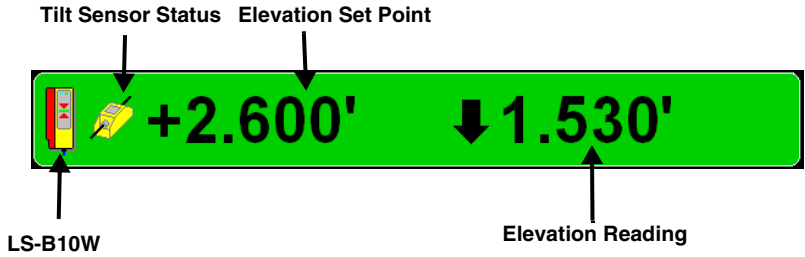

Figure 11-5. X-32 Cable Connections

Elevation Control Key (2D)



Adjust Elevation Screen (2D)



Creating an X-62/X-32 Machine Configuration File

1. Press **Topcon Logo** ▶ **Control** ▶ **Machine setup**.

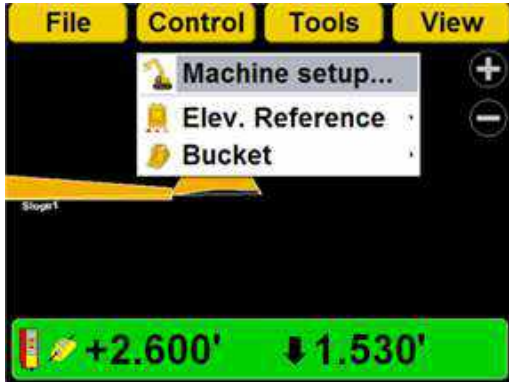

2. On the *Machine Files* screen, press **New**.



3. Select your machine type, **2D** as the Sensor type, and then select the desired Mounting location, and Units of measure. Press **Next**.

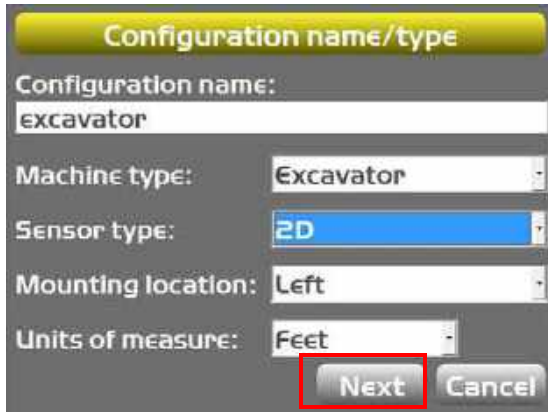

4. On the *Excavator Options* screen, select **GX-60** (or **GX-30** for X-32 systems) for the Sensor Input, and press **Next**.



5. Enter the appropriate information on the **Boom/ Body (1)** screen, and press **Next**.

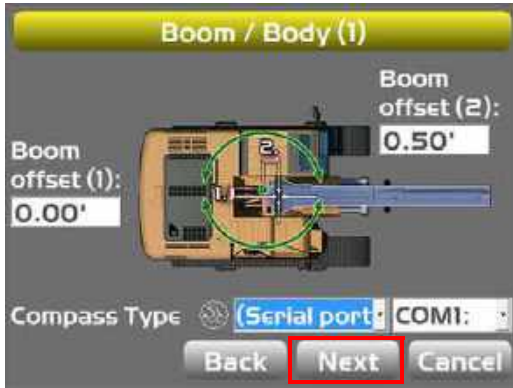

6. Enter your machine's measurement information on the **Boom/Body (2)** screen and press **Next**.



7. On the *Excavator Frame/Sensors* screen, enter the appropriate information for your machine and press **Next**.

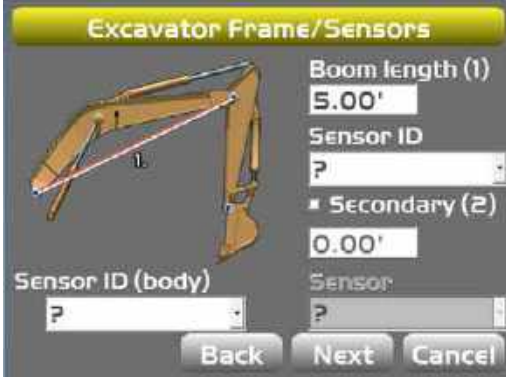

Excavator Frame/Sensors

Boom length (1)
5.00'

Sensor ID
P

Secondary (2)
0.00'

Sensor
P

Sensor ID (body)
P

Back Next Cancel

8. On the *Excavator Stick* screen, enter the appropriate information for your machine and press **Next**.



Excavator Stick

Stick length (1)
1.00'

Sensor ID (stick)
P

Back Next Cancel

9. On the **Bucket Sensor Mounting** screen, select the appropriate Sensor ID (bucket) and check the box next to Sensor mounted on dog-bone.



NOTE: If the dog-bone sensor option is not checked, this screen will not appear.

10. On the **Excavator DogBone** screen, enter the appropriate measurements for your machine and press **Next**.



Once you have setup the sensors for your machine, you can choose to calibrate a new or an existing bucket.

11. On the *Excavator Buckets* screen press **New** to create/calibrate a new bucket, or select an existing bucket and press **Edit**.

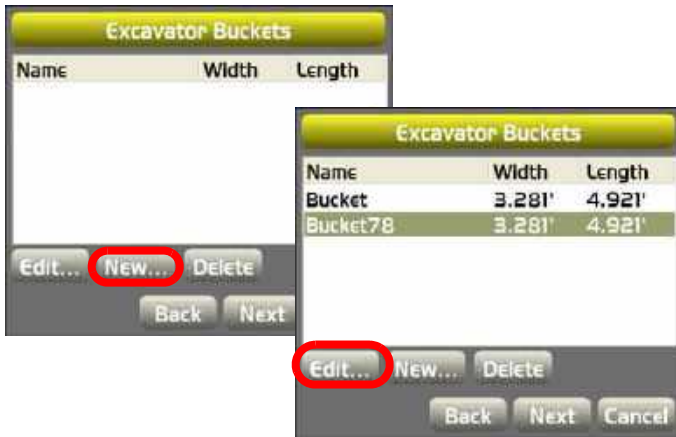

12. On the *Excavator Bucket Setup* screen, enter the appropriate information for your machine and press **Next**. If using a tilt bucket, check the Tilt bucket check box and enter the appropriate information.

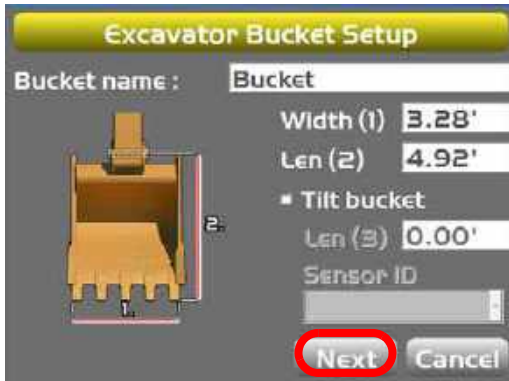

13. On the *Calibrate Bucket Edge* screen, press **Next**.

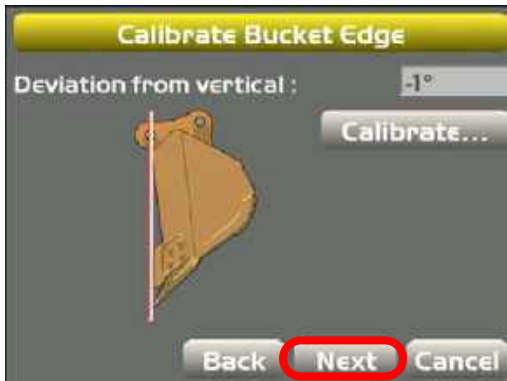

14. On the *Calibrate Bucket Base* screen, press **Finish**.
The Excavator Buckets screen appears.

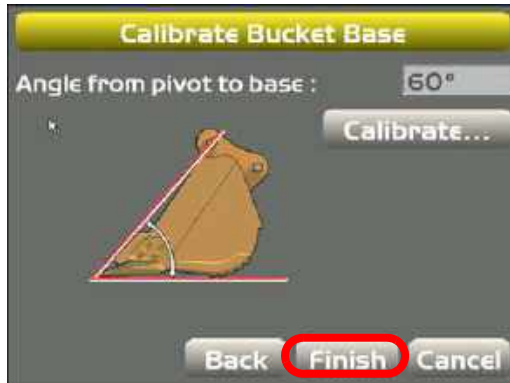

15. On the *Excavator Buckets* screen, press **Next**.



NOTE: The following steps do not apply for X-32 systems.

16.If you chose an LS-B10W as part of the sensor setup in step 3, enter the appropriate information for your machine at the **LSB10W** screen and press **Next**; otherwise, skip to step 17.



17.If using light bars, set the LD-40 information and press **Next**. If no light bars are in use, press **Next** to bypass the LD-40 setup parameters.



NOTE: For additional LD-40 instructions, see “LD-40 Light Bar Support” on page 6-13.

18. On the *Configuration Complete!* screen, press **Finish** to save the configuration.

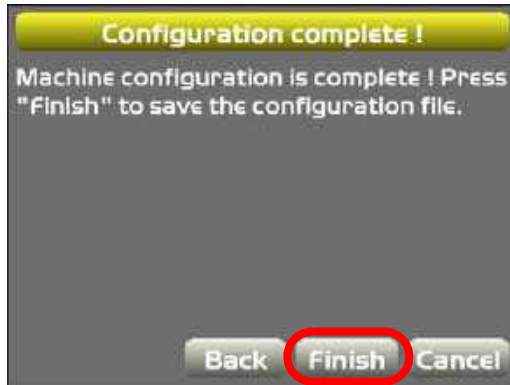

CAUTION: You must press Finish to save the file. Failure to do so will result in losing all entered information.

Slope Profiles

When using **Known Slope Profiles** and **Measured Slope Profiles**, a new height reference is required after every movement of the machine. A laser or the bucket teeth can be used as a height reference.

When using **Complex Slope Profiles**, a new height reference and a new position reference is also required after every movement of the machine.

Known Slope

To enter a known slope, press **Topcon Logo ▶ Tools ▶ Known Slope**, and enter the slope percentage or the rise and run values, and then press **Ok**.

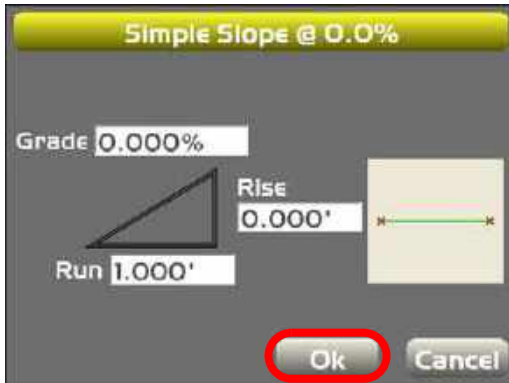

Known Dual Slope

To enter a known dual slope, click **Topcon Logo** ▶ **Tools** ▶ **Known Dual Slope**, and enter the *X/Y* slope percentage or the *X/Y* rise/run values, and then press **Ok**.

Dual Slope @ X0.0% Y0.0%

X Slope 0.000% X Slope

X Rise 0.000'

X Run 1.000'

Y Slope 0.000%

Y Rise 0.000'

Y Run 1.000'

Ok Cancel

Measured Slope

1. To create a simple slope by measuring an existing slope, click **Topcon Logo** ▶ **Tools** ▶ **Measured slope**.

Set the bucket teeth on the slope to be measured and press **Ok** at the prompt to measure the first point.

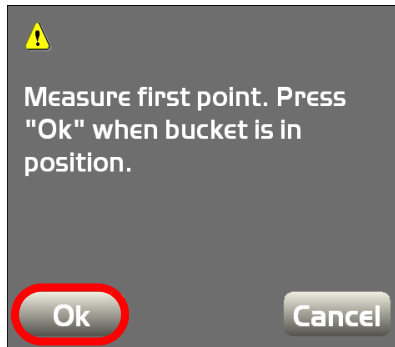

2. Move the bucket teeth to another location on the slope to be measured, and press **Ok** at the prompt to measure the second point.

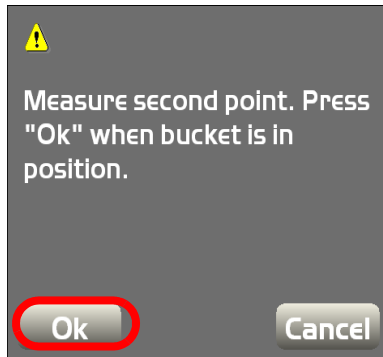

Complex Slope

1. To create a complex slope, press **Topcon Logo** ▶ **Tools** ▶ **Complex slope**.

Name the complex slope, and then press **Add** to create a new complex slope element.



2. Enter slope element values, and press **Ok**.

To manually measure a slope using the bucket teeth, set the bucket teeth on the slope to be measured and press **A** from the *Slope Element* screen, then move the teeth to another location on the slope and press **B**. The *Slope Element* screen

fields will automatically populate with the measured slope values.

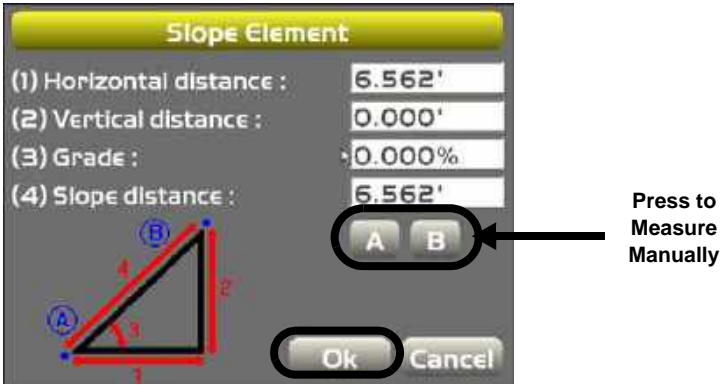

3. Repeat steps 1 and 2 to add more slope elements to the complex slope.

Normal to Surface To indicate a surface cut/fill that is perpendicular (normal) to the surface model of an excavator instead of always vertical, click **Control ▶ Elev. Reference ▶ Normal to surface**.



Referencing

Zero to Bucket

Press **Zero to bucket** to use the bucket teeth as the height reference for Known, Measured, and Complex Slope profiles.

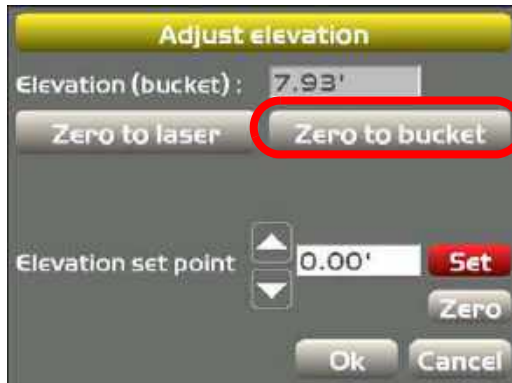

Zero to Laser

Press **Zero to laser** to use the LS-B10W as the height reference for Known, Measured, and Complex Slope profiles.

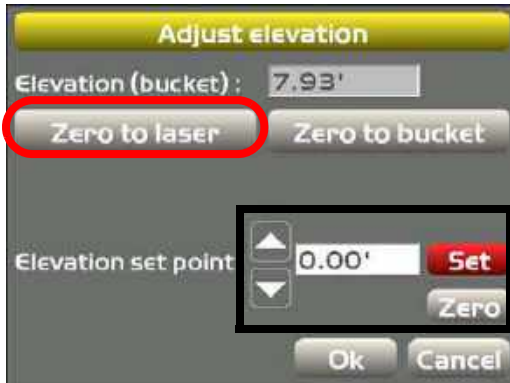

For Complex Slope profiles only: When using an active Complex Slope profile, a new window appears (not shown) prompting the user to place the bucket teeth in the selected position.

Follow the on-screen instructions, and press **Ok**.

Reverse Slope Direction

To reverse the slope direction press **Topcon Logo** ▶ **Tools** ▶ **Reverse slope direction**.



Troubleshooting

Before contacting TPS Customer support about any problems, try the following and see the following sections:

- Check that the various components for your Topcon 3D Machine Control system (radio, MC-R3 Controller, GX-60 Control Box, MC² Sensor, Base Station receiver) have power and are powered up.
- Check that all cables are securely and properly connected to the various components of system.
- Disconnect cables and inspect them for damage or contamination. Clean all connections with an electrical contact cleaner.

Base Station

This section lists possible Base Station problems you may encounter (also refer to the Base Station’s documentation) for 3D Machine Control. If you still have problems after trying the solutions listed here, contact TPS customer support.

Problem	
Receiver does not power on.	
Causes	Solutions
The PWR button was pressed too quickly.	Make sure you hold the PWR button down for at least one second. A quick press will not activate the receiver.
The power cable is incorrectly connected or damaged.	<p>Check that the power cable is correctly connected to the battery—RED to positive and BLACK to negative—and that the battery is charged.</p> <p>Check that the RED dots on the power cable connector and the socket on the receiver are aligned, and the cable is pushed in as far as it can go.</p> <p>If the power cable is damaged, contact your dealer to replace it.</p>

Problem	
Radio modem does not power on.	
Causes	Solutions
The power cable is incorrectly connected or damaged.	<p>Check that the power cable is correctly connected to the battery—RED to positive and BLACK to negative—and that the battery is charged.</p> <p>If the power cable is damaged, contact your dealer to purchase a new cable.</p>
The radio receives power through the receiver.	Some radios do not require a separate power supply, but are supplied power through the port on the receiver. For these radios, check that the receiver is also switched on.
Problem	
Pocket-3D does not connect to receiver.	
Causes	Solutions
The receiver may be off.	Check that the receiver is switched on.

<p>The cable may be incorrectly connected.</p>	<p>Check that the cable is connected to the COM port on the computer and Port A on the receiver.</p> <p>If still no connection, try to reset the computer and repeat.</p>
<p>Problem</p>	
<p>Pocket-3D is waiting for satellites.</p>	
<p>Causes</p>	<p>Solutions</p>
<p>The cable is incorrectly connected or damaged.</p>	<p>Check that the antenna cable is not cross-threaded and is screwed in all the way.</p> <p>If the cable is damaged, contact your dealer to purchase a new cable.</p>
<p>The antenna has poor PDOP.</p>	<p>Check that the antenna has a clear view of the sky.</p>
<p>The receiver is collecting an almanac.</p>	<p>If this is the first time connecting to the receiver, or if an internal reset has recently been performed, this message may persist for several minutes while the receiver obtains a new almanac.</p>

Problem	
Radio modem light is not flashing	
Causes	Solutions
The cable is incorrectly connected or damaged.	Check that the cable from the receiver is properly connected to the radio. If the cable is damaged, contact your dealer to purchase a new cable.
The radio does not have a TX LED.	Some radios may not have a TX (Transmit) LED so the radio may in fact be functioning.
The radio has a TX LED, but it is not yet flashing.	All radio types specifically listed for the Base Station kit have a TX light and should flash every second. It may take several seconds after connection for this flashing to commence.

G X -60 Control Box

This section lists possible display problems you may encounter. If you still have problems after trying the solutions listed here, contact TPS customer support.

Problem	
Display does not power on.	
Causes	Solutions
The cable is the wrong cable, incorrectly connected, or damaged.	<p>Check that the power cable supplies 12 to 24 VDC and is negative conductive.</p> <ul style="list-style-type: none"> • A socket (positive) = 12 to 24 VDC • E socket = Ground <p>Check that the power cable is connected to the correct port and the ends are securely fastened.</p> <p>If the cable is damaged, contact your dealer to purchase a new cable.</p>
Problem	
Screen display turns off by itself.	
Causes	Solutions

<p>The fan may be damaged, causing the display to overheat.</p>	<p>Check that the fan is rotating.</p> <p>If the fan is not rotating, it may be damaged and needs to be replaced with a new one. Contact your dealer.</p> <p>Contact your dealer for information on replacing the fan.</p>
---	--

Problem

Screen display goes dim by itself

Causes

Solutions

The fan may not be rotating.

Check that the fan is rotating.

If the fan is not rotating, it may be damaged and needs to be replaced with a new one. Contact your dealer for information on replacing the fan.

The display has the self-adjusting ability of screen brightness.

Brightness may be dimmed when the display gets over-heated with high temperature around the cab, as well as when the ambient light becomes dim.

The backlight also reduces when the ambient light becomes dim.

Problem

Screen has transferred to operating system.

Causes

Solutions

<p>“Exit 3DMC” function may have been pressed unexpectedly or incorrectly.</p>	<p>If the screen displays the desktop, the “My Computer” folder should be visible.</p> <ol style="list-style-type: none"> 1. Double-tap “My Computer” folder. 2. Look for the folder named “Disk C”, and double-tap on it. 3. Look for the “Control Box” icon and double-tap. The application program opens and returns to the Main Screen.
--	--

Problem

“Control file has no GPS localization” message.

Causes	Solutions
<p>No GPS localization has been performed for the project.</p>	<p>Plan to implement the GPS localization.</p>

Problem

“Loading....” or “Building....” message.

Causes	Solutions
--------	-----------

<p>The program in the display is in the middle of loading files or making graphics.</p>	<p>If the pointer on the Main Screen moves when you press in different places, the display is computing.</p> <p>When the system is busy, the pointer becomes an hourglass.</p> <p>Wait for a few more minutes to let it complete the process.</p> <p>Remember, computing will take longer when a larger file is selected.</p>
<p>If the pointer does not move, the display may have a computing problem.</p>	<p>Switching off the display can fix the computing problem.</p>
<p>Problem</p>	
<p>Elevation/Slope Control pad displays: “GPS receiver not connected!”</p>	
<p>Causes</p>	<p>Solutions</p>

<p>Either the GPS+ signal or radio signal is invalid. The graphic may indicate what causes the problem.</p>	<p>For GPS+ signal, check cable connections along the GPS antenna cable from the GPS Antenna port on the MC-R3 Controller to the Rover Antenna. Check cable connections at the MC-R3 Controller and at the display.</p>
---	---

Problem

Elevation Control key displays:
“Waiting for radio link”

Causes	Solutions
<p>Radio transmission, radio antenna, lights status on the receiver, and/or power may have a problem.</p>	<p>Check that the Base Station is working correctly. Also check that the Rover Radio Antenna on the machine and its cable connections are properly connected. Make sure that the radio channel is identical between the Base Station and the Machine Rover, and that the radio is correctly configured on the display.</p>

Problem	
Elevation Control key displays: “Waiting for Initialization”	
Causes	Solutions
The GPS+ receiver has not been successful tracking enough valid satellites.	Check that the Rover Antenna has a clear view of the sky. Check for obstructions, such as trees, buildings, and vehicles, that can block or reflect satellite signals.
The system is still in the process of determining a solid position.	If this is the very first time operation, this message may persist for several minutes while the receiver obtains a new almanac.
Problem	
Elevation Control key displays: “Out of design area”	
Causes	Solutions
The machine is out of the Design Surface area.	Make sure that the correct Project file is selected and Surface file is made active. Move into the Design Surface area so the operator can begin grading.

Problem	
Elevation Control key displays : “No GPS localization”	
Causes	Solutions
The Layer currently selected has not been localized properly.	Make sure that the correct Layer is selected.
You are in a process of building a Control Point file or just starting the process.	Disregard the message until the localization is complete.
Problem	
Slope Control key displays: “3DMC ² sensor not connected!”	
Causes	Solutions
Cross slope system is not connected properly.	Check cable connections display, the MC ² Sensor.

Wrong sensor type selected in 3D-MC Machine Configuration.	Select the MC ² sensor type in 3D-MC.

M C R 3 Controller/Receiver

LED Status Chart

The CAN, Sensor, Control, and Auto LED's in the chart below have a heartbeat to indicate proper operation of the processor.

7 EA BI-COLOR RED/GREEN STATUS			
CAN			
	STATUS	RED	GREEN
	CAN Communication OK	Off	On
	No CAN Communication	On	Off
	No CAN Required	Off	Off
SENSOR			
	STATUS	RED	GREEN
	Sensor Communication OK	Off	On
	No Sensor Communication	On	Off
	Firmware Loading	Alternate Flashing Red/Green (LED flashes alternately with Control LED)	
CONTROL			
	STATUS	RED	GREEN
	GUI Communication OK; Current	Off	On
	GUI Communication Established; Not Current	Off	Blinking
	No GUI Communication	On	Off
	Firmware Loading	Alternate Flashing Red/Green (LED flashes alternately with Sensor LED)	
AUTO			
	STATUS	RED	GREEN
	Not in Automatic	On	Off
	One Side in Automatic	Off	Blinking
	Both Sides in Automatic	Off	On

7 EA BI-COLOR RED/GREEN STATUS			
RADIO RX			
	STATUS	RED	GREEN
	Power	Off	On
	Receiving Radio Signal	1 Blink per Second for Each Reception of Data	On
MAIN and AUX (GPS ANTENNAS)			
	STATUS	RED	GREEN
	Tracking GPS	Off	1 Blink for Each Satellite Tracked
	Tracking Glonass	1 Orange Blink for Each Satellite Tracked - Red and Green Blink Together	
	Firmware Download	Alternate Flashing Red/Green	

This section lists possible MC-R3 Controller/Receiver problems you may encounter. If you still have problems after trying the solutions listed here, contact TPS customer support.

Problem	
All LEDs off.	
Causes	Solutions
The power cable may be incorrectly connected.	Power is supplied through the cable connected on the power port. Check that the cable is properly connected

<p>The Display does not have power.</p>	<p>The MC-R3 Controller turns on only when the Display is also powered on.</p>
<p>Problem</p>	
<p>Satellite Status indicator does not flash green.</p>	
<p>Causes</p>	<p>Solutions</p>
<p>The cable is incorrectly connected or damaged.</p>	<p>Check that the antenna cable is not cross-threaded at the antenna and is connected to the intermediate cable installed on the machine.</p> <p>Check the connection at the GPS Antenna port on the MC-R3 Controller.</p> <p>If the cable is damaged, contact your dealer to purchase a new cable.</p>
<p>The antenna has poor PDOP.</p>	<p>Check that the Machine Antenna has a clear view of the sky.</p>
<p>The receiver is collecting an almanac.</p>	<p>If this is the first time connecting to the MC-R3 Controller, the LED may not flash for several minutes while the GPS receiver obtains a new almanac.</p>
<p>Problem</p>	
<p>Radio Status indicator does not flash green.</p>	

Causes	Solutions
The Base Station and/or Base Station radio has a problem.	Check that the Base Station is running correctly and the TX light on the radio modem flashes on.
Different channels are used between the Base Station and the machine.	<p>Check that the Base Station and Machine use the same radio channel.</p> <ul style="list-style-type: none"> • For the Base Station, use the button on the radio modem or use the “GPS Radio Configuration” program with the Pocket-3D connected. For the machine, use the Control Box function.
The antenna at the Rover or Base may be too low, incorrectly placed, or too far away.	<p>If the green LED flashes when near the Base Station, but not when farther away, check that the Machine Radio Antenna mast is mounted vertically at the highest point on the machine.</p> <p>If the machine gets too far from the Base Station, elevate the radio antenna at the Base Station or move it to a closer Control Point.</p>

M C ² Sensor

LED Status Chart

7 EA BI-COLOR RED/GREEN STATUS			
RADIO RX			
	STATUS	RED	GREEN
	Power	Off	On
	Receiving Radio Signal	1 Blink per Second for Each Reception of Data	On

Problem	
LED off.	
Causes	Solutions
The power cable may be incorrectly connected.	Power is supplied through the cable connected on the power port. Check that the cable is properly connected

GPS Localization

This section lists possible GPS localization problems you may encounter. If you still have problems after trying the solutions listed here, contact TPS customer support.

Problem	
Measurement takes too long.	
Causes	Solutions

The machine may be blocking satellite signals to the range-pole or tripod-mounted antenna.	Watch the status of the measurement screen. If the status indicates “waiting for satellites” move the machine away from the antenna.
The Control Point may be located too close to obstructions.	Move to an alternative Control Point or have the surveyor place a new Control Point away from the obstructions.
The MC-R3 Controller has not yet initialized; the system may be tracking many satellites.	The MC-R3 Controller may take several minutes to initialize.
The range-pole was unsteady.	Make sure that the pole is held steady while measurement is taking place. Any movement will make for a lengthy initialization and/or measurement.
Problem	
Localization produces large errors.	
Causes	Solutions

<p>A typographical error occurred.</p>	<p>If errors are 10s or 100s of feet or meters, it is likely that a typographical error has occurred.</p> <p>If coordinates are manually entered, check that longitudes are correctly prefixed with a minus sign if working in the western hemisphere (e.g., USA).</p> <p>Re-enter the coordinates.</p>
<p>The range-pole was unsteady.</p>	<p>If the errors are decimeter level in magnitude, it may point to either inaccurately measured local site coordinates or not holding the range-pole vertical when measuring the GPS coordinates.</p>
<p>Inaccurate local site coordinates or erroneous GPS measurement.</p>	<p>If error values of the first few points are reasonable but increase when a new point is measured, the point just measured must have either inaccurate local site coordinates or erroneous GPS measurement.</p>

To isolate the error, disable horizontal and/or vertical localization for each Control Point in turn and observe the set of errors.

When the errors become acceptable due to certain isolation, the point isolated is most likely to detract from the quality of the localization.

Also, as a general rule, if error values of the first few points are reasonable but increase when a new point is measured, the point just measured must have either inaccurate local site coordinates or erroneous GPS measurement.

Once a problematic Control Point is discovered, try to re-measure the point again to see any improvement. If it is still suspect and affects the acceptable tolerance, the horizontal and/or vertical localization for this point may be disabled.

Problem	
There are no H.Error and V.Error values.	
Causes	Solutions
<p>“Use for horizontal GPS localization” and/or “Use for vertical GPS localization” check boxes may not have been selected.</p>	<p>These check boxes need to be selected for a minimum of three points. Note that the error value will be calculated once three Control Points are measured and used for the GPS localization. This troubleshooting is useful when the Pocket-3D is being used to perform GPS localization as well as the display.</p>

Blade Response

This section lists possible Blade Response problems you may encounter. If you still have problems after trying the solutions listed here, contact TPS customer support.

Problem	
Blade is moving too slowly. The blade seems to move too slowly in Control Mode. The Grade Indicator takes too long to reach grade.	
Causes	Solutions
The Valve Gain setting is too low.	<p>Increase the Valve Gain setting, which will cause the hydraulics to respond quicker.</p> <p>Check which control is slow before adjusting the Valve Gain. Remember that the larger number setting speeds up the response.</p>

Problem	
Blade is moving too fast. The blade seems to move too fast in Control Mode. The Grade Indicator skips through on-grade.	
Causes	Solutions
The Valve Gain setting is too high.	Decrease the Valve Gain setting, which will cause the hydraulics to respond slower. Check which side control is fast before adjusting the Valve Gain. Remember that the lower number setting slows down the response.
Problem	
Blade reacts, but does not reach On Grade	
Causes	Solutions
Valve Offsets are too small.	Assume that Valve Offsets are too small, and perform a Valve Offsets Calibration.
Problem	
Blade reacts, but overshoots around On Grade	
Causes	Solutions
Valve offsets are too large.	Assume that Valve Offsets are too large, and perform a Valve Offsets Calibration.

MC-R3/MC-i3 Configurations

Table A-1. MC-R3 Configuration Options

MC-R3 Configurations	Position Input	Control Output	Sensor Input	GPS Comms Configurati on Screen?
MC-R3/GX-60 (w/ E112 GPS Boards) w/Auto	MC-R3	MC-R3	MC-R3	No
MC-R3/GX-60 (w/ E112 GPS Boards) - w/ Auto & MC2	MC-R3	MC-R3	MC-R3 w/ 3DMC ²	No
MC-R3/GX-60 (w/ E112 GPS Boards) - No Auto	MC-R3	n/a	MC-R3	No

Table A-2. MC-i3 Configuration Options

MC-i3 Configurations	Position Input	Control Output	Sensor Input	GPS Comms Configurati on Screen?
MC-i3 (UHF/SS)/GX-60	MC-i3 (UHF/SS)	n/a		
MC-i3 (UHF/SS)/GX-30	MC-i3 (UHF/SS)	n/a		
MC-i3 (SL-R3)/GX-60	MC-i3 (SL-R3)	n/a		
MC-i3 (SL-R3)/GX-30	MC-i3 (SL-R3)	n/a		

Table A-3. Custom Configuration Options

Custom Configurations	Position Input	Control Output	Sensor Input	GPS Comms Configuration on Screen?
MC-R3/GX-60 (w/ 160 GPS Boards)	Custom	MC-R3	MC-R3	Yes (UDP)
MC-R3/GX-60 (w/ 160 GPS Boards and old firmware)	Custom	MC-R3	MC-R3	Yes (TCP/IP)
MC-2.5/GX-60	Custom	n/a	None	Yes (Serial)
MC-2.5/GX-60 (using TS-1 sensors)	Custom	n/a	GX-60	Yes (Serial)

For custom setups, select your Connection type and enter the IP Address, Port, and Password (for TCP/IP connections) and press **Next**





Topcon Positioning Systems, Inc.
7400 National Drive, Livermore, CA 94550
800-443-4567 www.topconpositioning.com



ISO 9001:2000
FM 68448

3DMC Reference Guide
P/N: 7010-0911 Rev E

©2013 Topcon Positioning Systems, Inc. All rights reserved. No unauthorized duplication.