



EQUIPMENT AUTOMATION: PAVER

**TOPCON**

**SYNERGY**  
POSITIONING SYSTEMS

For more information contact Synergy Positioning Systems or visit the Synergy Positioning Systems website at [www.synergypositioning.co.nz](http://www.synergypositioning.co.nz)  
All branches: Phone 0800 867 266 Email: [info@synergypositioning.co.nz](mailto:info@synergypositioning.co.nz)



# Paver

System 5 & Smoothtrac®  
Operator's Manual

*Tracker II*





# **Paver System Five Operator's Manual**

Part Number 7010-0341

Rev F

**©Copyright Topcon Positioning Systems, Inc.**

**April, 2004**

All contents in this manual are copyrighted by Topcon. All rights reserved. The information contained herein may not be used, accessed, copied, stored, displayed, sold, modified, published, or distributed, or otherwise reproduced without express written consent from Topcon.



# Table of Contents

<b>Preface .....</b>	<b>vii</b>
Terms and Conditions .....	vii
Manual Conventions .....	x
 <b>What's New... ..</b>	 <b>xi</b>
 <b>Chapter 1</b>	
<b>System Overview .....</b>	<b>1-1</b>
Getting Acquainted .....	1-3
Control Box .....	1-3
Sonic Tracker II .....	1-4
Slope Sensor .....	1-5
Smoothtrac Sonic Averaging System (SAS) .....	1-6
Laser Tracker & Trackerjack .....	1-7
Care and Preventive Maintenance .....	1-8
 <b>Chapter 2</b>	
<b>Paving Principles &amp; Control Methods .....</b>	<b>2-1</b>
Paver Components .....	2-1
How a Screed Works .....	2-2
Tow Point Force ("P") .....	2-5
Truck Exchange, Another Tow Point Force .....	2-6
Head of Material ("M") .....	2-7
Reaction of Material Under Screed ("R") .....	2-9
Gradation Mix Characteristics .....	2-9
Mix Temperature Characteristics .....	2-11
Weight of Screed ("W") .....	2-12
Quality of Base Being Paved .....	2-13
Rolling Techniques .....	2-14

Controlling Mat Quality .....	2-14
Control Methods .....	2-15
Sonic Control .....	2-15
Working Window and Sonic “Footprint” .....	2-16
Sonic Tracker Operation and its Position .....	2-18
Sonic Tracker and Temperature Changes .....	2-22
Laser Control .....	2-24
Slope Control .....	2-26
<b>Chapter 3</b>	
<b>Stringline Setup .....</b>	<b>3-1</b>
Setting Surface Stringline .....	3-2
Setting Elevated Stringline .....	3-5
Making a Cut/Fill Lath .....	3-7
Attaching Stringline to the Grade Stake .....	3-9
Setting Projected Slope Stringline .....	3-10
Verifying Grade .....	3-12
<b>Chapter 4</b>	
<b>Operation &amp; Menu Settings .....</b>	<b>4-1</b>
Control Box .....	4-2
LCD .....	4-3
Light Sensor for LED Display .....	4-3
Power Switch .....	4-3
Grade Adjustment Knob .....	4-4
Grade Adjustment Direction Arrows .....	4-5
Grade Adjustment LEDs .....	4-5
Function Indicator LEDs .....	4-6
Set/Menu Button .....	4-7
Using the Set Mode .....	4-7
Using the Menu Mode .....	4-8
Cross Communication Button .....	4-8
Slope/Elevation Button .....	4-11
Slope Mode .....	4-11
Elevation Mode .....	4-11

Survey/Indicate Button .....	4-12
Using the Survey Function .....	4-12
Using the Indicate Function .....	4-12
Auto/Manual Button .....	4-13
Using Automatic Mode .....	4-13
Using Manual Mode .....	4-13
Making Selections in the Performance Menu .....	4-14
Jog Button .....	4-14
Other Control Box Components .....	4-14
Performance Menu Settings .....	4-16
Gain (Elevation) .....	4-20
Gain (Slope Control) .....	4-21
Valve Offset .....	4-23
Averaging .....	4-26
Deadband Elevation .....	4-27
Deadband Slope .....	4-29
Beeper Alarm .....	4-31
Unit .....	4-32
Test .....	4-34

## Chapter 5

<b>Getting Ready to Pave .....</b>	<b>5-1</b>
Control Box Setup .....	5-2
Screed Setup .....	5-3
Sonic Tracker Setup .....	5-4
SAS Setup .....	5-6
Control Box Setup for Elevation .....	5-7
Control Box Setup for Cross Slope .....	5-11

## Chapter 6

<b>Tracker and SAS Placement .....</b>	<b>6-1</b>
Sonic Tracker Positioning in Relation to Reference .....	6-2
L-bar Positioning .....	6-3
Cub and Gutter Tracking .....	6-5
Joint Matching and Tracking Sub-grade .....	6-5
Placement When Using a Temperature Bail .....	6-6

Placement When Using a Mechanical Ski .....	6-6
Placement When Using Elevated Stringline .....	6-7
Placement When Using Surface Stringline .....	6-8
Sonic Tracker Placement in Relation to Screed .....	6-8
Smoothtrac SAS Placement and Setup .....	6-13
Positioning the SAS .....	6-16
Placement of SAS on Paver .....	6-19
<b>Chapter 7</b>	
<b>Paving Applications .....</b>	<b>7-1</b>
Paving City Streets with Sonics .....	7-1
Paving City Streets with Cross Slope .....	7-4
Paving Streets Through Intersections .....	7-7
Method 1 for Paving Intersections .....	7-7
Method 2 for Paving Intersections .....	7-9
Paving Intersections with Cross Slope .....	7-10
<b>Chapter 8</b>	
<b>Maintenance .....</b>	<b>8-1</b>
Preventative Maintenance & Daily Care .....	8-1
Sonic Tracker II Transducer Cleaning .....	8-2
Sonic Tracker II Transducer Replacement .....	8-3
<b>Chapter 9</b>	
<b>Troubleshooting .....</b>	<b>9-1</b>
Control Box Symptoms .....	9-1
Tracker Symptoms .....	9-11
Slope Sensor Symptoms .....	9-14
SAS Symptoms .....	9-17
<b>Appendix A</b>	
<b>Safety Precautions .....</b>	<b>A-1</b>



**Appendix B**

**Limited Warranty ..... B-1**

- Electronic and Mechanical Components ..... B-1
- Return and Repair ..... B-1
- Warranty Disclaimer ..... B-1
- Service Information ..... B-2

**Glossary**

**Index**

# Notes:

---

---

---

---

---

---

---

---

---

---

---

---

---

---

---

---

---

---

---

---

---

---

---

---

---

---

---

# Preface

This manual has been developed to provide the operator with information necessary to operate and maintain TOPCON products. Proper service and use is important to the reliable operation of the equipment. The procedures described herein are effective methods for performing service and operation of this system.



## NOTICE

*Please read these Terms and Conditions carefully.*

## Terms and Conditions

**USE** – Please study this manual carefully. The benefits this product provides can be greatly influenced by your applications knowledge.

**COPYRIGHT** – All information contained in this Manual is the intellectual property of, and copyrighted material of Topcon Positioning Systems (TPS). All rights are reserved. You may not use, access, copy, store, display, create derivative works of, sell, modify, publish, distribute, or allow any third party access to, any graphics, content, information or data in this Manual without Topcon's express written consent and may only use such information for the care and operation of your product. The information and data in this Manual are a valuable asset of TPS and are developed by the expenditure of considerable work, time and money, and are the result of original selection, coordination and arrangement by TPS.

**TRADEMARKS** – System Five™, Topcon® and Topcon Positioning Systems™ are trademarks or registered trademarks of TPS. Windows® is a registered trademark of Microsoft Corporation. Product and company names mentioned herein may be trademarks of their respective owners.

**DISCLAIMER OF WARRANTY** – EXCEPT FOR ANY WARRANTIES IN AN APPENDIX OR A WARRANTY CARD ACCOMPANYING THE PRODUCT, THIS MANUAL AND THE PRODUCTS ARE PROVIDED “AS-IS.” THERE ARE NO OTHER WARRANTIES. TPS DISCLAIMS ANY IMPLIED WARRANTY OF MERCHANTABILITY OR FITNESS FOR ANY PARTICULAR USE OR PURPOSE. TPS AND ITS DISTRIBUTORS SHALL NOT BE LIABLE FOR TECHNICAL OR EDITORIAL ERRORS OR OMISSIONS CONTAINED HEREIN; NOR FOR INCIDENTAL OR CONSEQUENTIAL DAMAGES RESULTING FROM THE FURNISHING, PERFORMANCE OR USE OF THIS MATERIAL OR THE PRODUCT. SUCH DISCLAIMED DAMAGES INCLUDE BUT ARE NOT LIMITED TO LOSS OF TIME, LOSS OR DESTRUCTION OF DATA, LOSS OF PROFIT, SAVINGS OR REVENUE, OR LOSS OF THE PRODUCT’S USE. IN ADDITION TPS IS NOT RESPONSIBLE OR LIABLE FOR DAMAGES OR COSTS INCURRED IN CONNECTION WITH OBTAINING SUBSTITUTE PRODUCTS OR SOFTWARE, CLAIMS BY OTHERS, INCONVENIENCE, OR ANY OTHER COSTS. IN ANY EVENT, TPS SHALL HAVE NO LIABILITY FOR DAMAGES OR OTHERWISE TO YOU OR ANY OTHER PERSON OR ENTITY IN EXCESS OF THE PURCHASE PRICE FOR THE PRODUCT.

**WEBSITE and OTHER STATEMENTS** – No statement contained at the TPS website (or any other website) or in any other advertisements or TPS literature or made by an employee or independent contractor of TPS modifies these Terms and Conditions (including the Software license, warranty and limitation of liability).

**SAFETY** – Improper use of the Product can lead to injury to persons or property and/or malfunction of the product. The product should only be repaired by authorized TPS warranty service centers. Users should review and heed the safety warnings in Manual.

**MISCELLANEOUS** – The above Terms and Conditions may be amended, modified, superseded, or canceled, at any time by TPS. The above Terms and Conditions will be governed by, and construed in accordance with, the laws of the State of California, without reference to conflict of laws.

All information, illustrations, and applications contained herein are based on the latest available information at the time of publication. TOPCON reserves the right to make product changes at any time without notice.

Comments, suggestions, and questions about TOPCON products are welcomed. Contact your local TOPCON representative or a representative at our corporate facility.

TOPCON POSITIONING SYSTEMS, Inc.

5758 W. Las Positas Blvd.

Pleasanton, CA 94588

925 / 460 1300

925 / 460 1315 FAX

## Manual Conventions

This manual uses the following conventions:



Supplementary information that can help to configure, maintain, or set up a system.



*Supplementary information that can have an affect on system operation, system performance, measurements, personal safety.*



***Notification that an action has the potential to adversely affect system operation, system performance, data integrity, or personal health.***



**Notification that an action *will* result in system damage, loss of data, loss of warranty, or personal injury.**



**UNDER NO CIRCUMSTANCES SHOULD THIS ACTION BE PERFORMED.**

# What's New...

This manual includes the changes for version 1.7 of the 9256 Control Box code.

## **In this version:**

The range of the following settings has changed:

- Gain (Elevation) range is now 1–200
- Gain (Slope) range is now 1–200

See “Performance Menu Settings” on page 4-16 and Table 4-2 on page 4-16 for more information on menu settings.





# System Overview

System Five™ is a complete, non-contacting control system which combines both elevation control and slope control into a simple, easy to use package (Figure 1-1).

The primary function of System Five is to provide screed control so that the paving material is placed into position at the correct elevation and slope.

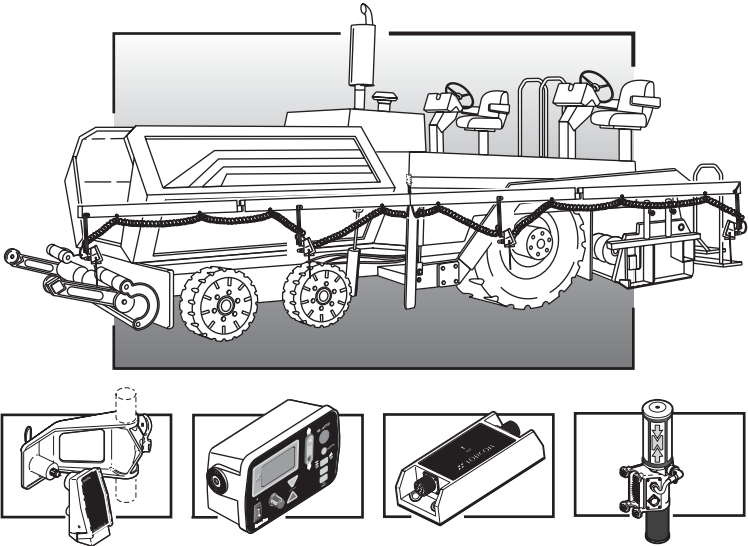

Figure 1-1. Paver System Five Components

Figure 1-2 displays the setup of components on a screed.

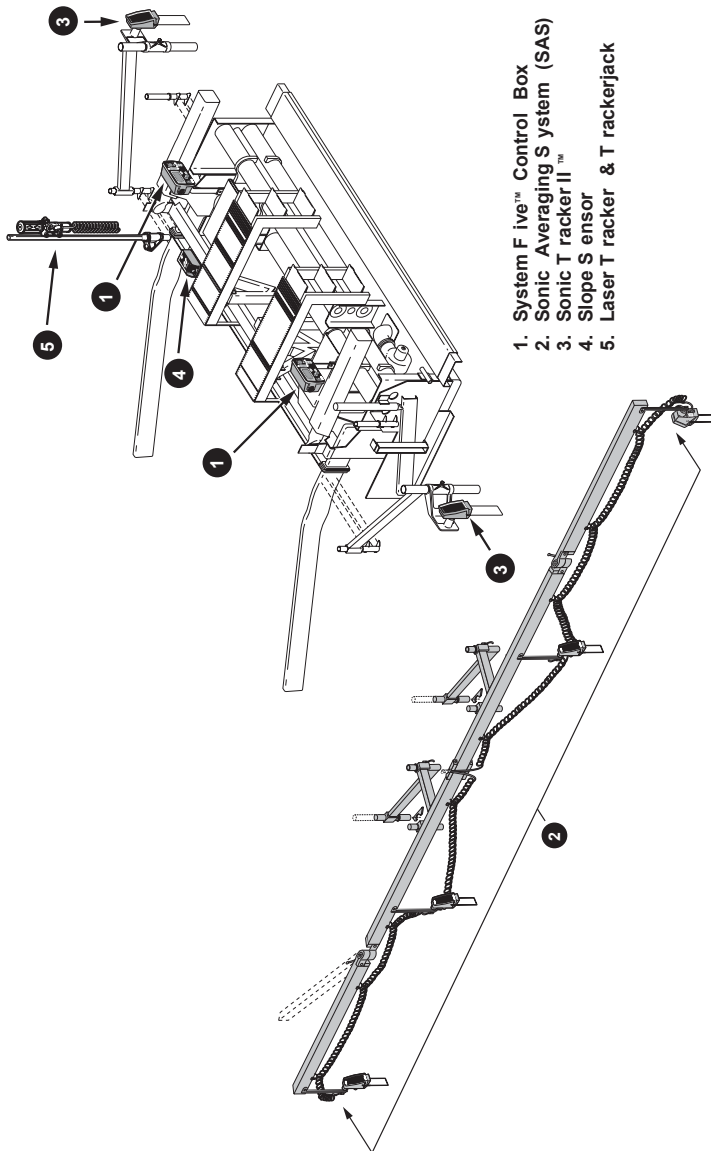

Figure 1-2. Paver System Five Top View

## Getting Acquainted

A standard System Five Paver system includes two Control Boxes, two Sonic Trackers and a single Slope Sensor. When setup and connected, the Control Boxes control either the left or right side of the machine for either elevation or slope.

### Control Box

The Control Box (Figure 1-3) is the operator's interface to System Five. The Control Box receives signals from the sensors (Sonic Tracker II™, Laser Tracker, and/or Slope Sensor), and uses these signals to determine if grade or slope corrections are necessary. If a change in grade or slope is required, the Control Box sends a signal to the valve controlling the tow point cylinder on the appropriate side of the machine to raise or lower, thus maintaining correct mat thickness.

The Control Box connects to the Sonic Tracker II™, the Slope Sensor, and to the paver through electrical cables. The Control Box easily attaches to its mounting bracket with one clamp, and at the end of the day should be removed for storage.

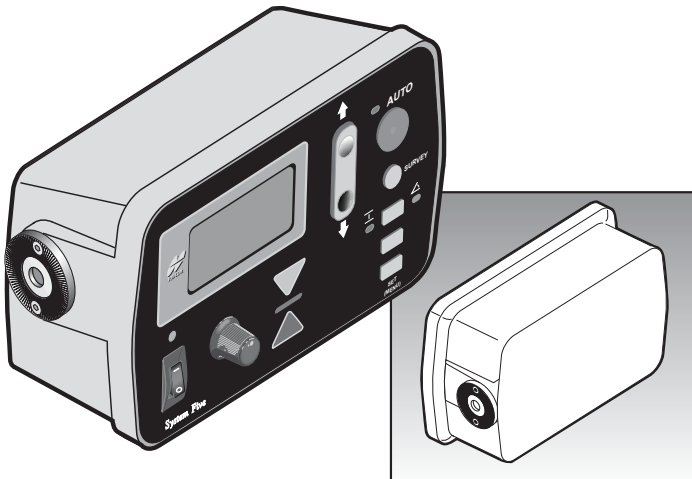

Figure 1-3. Control Box

## Sonic Tracker II

The Sonic Tracker II™ (Figure 1-4) measures and controls the elevations of the screed. A transducer, located in the bottom of the Sonic Tracker II™, generates sound pulses like a speaker and listens for returned echoes like a microphone. The Tracker measures the distance, and controls grade from a physical grade reference, such as a curb, stringline, or existing road surface. A bail is used to compensate for rapid air temperature changes. In paving applications a bail should always be used.

The Sonic Tracker II attaches to the system through one quick connect cable and attaches to the machine with a single bolt. At the end of the day, Sonic Tracker II should be removed for proper storage in the carrying case.

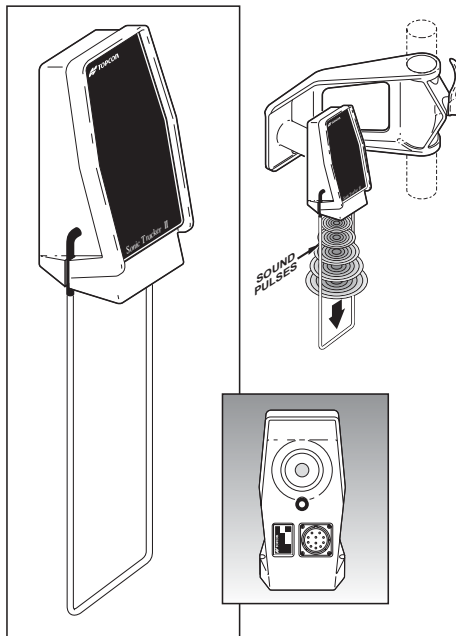

Figure 1-4. Sonic Tracker II

## Slope Sensor

The slope sensor (Figure 1-5) is a precision electronic sensor which functions much like a precision carpenter's level. The slope sensor reads the inclination (tilt) of the screed and sends the signal to the Control Box. The slope sensor measures slopes from +20% to -20%.

The slope sensor connects to each Control Box through an electrical cable and requires no adjustments, and is the only component of System Five that can be used to control either side of the paver. The slope sensor is a sealed component, and once attached to the Paver, should not be removed.

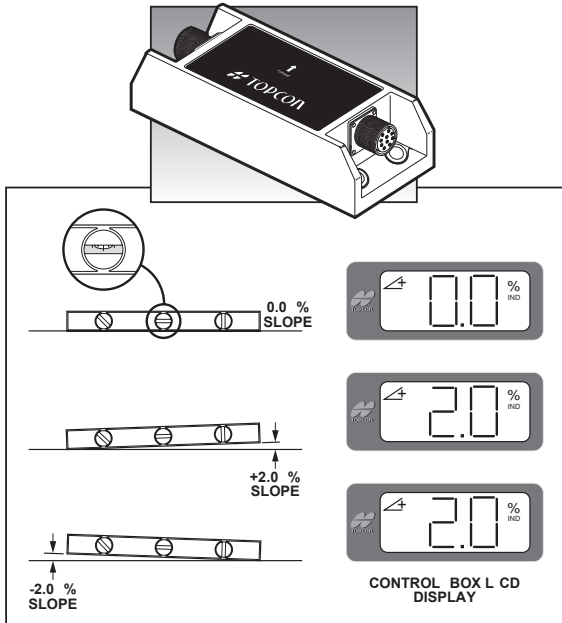

Figure 1-5. Slope Sensor

## Smoothtrac Sonic Averaging System (SAS)

The Smoothtrac® SAS (Figure 1-6) is an elevation control system that combines multiple sonic trackers to calculate an average of the physical reference. Each tracker sends its distance measurement to the Control Box which then averages those measurements and sends a correction signal to the tow point cylinder. The Smoothtrac replaces the mechanical ski that drags on the ground.

The Smoothtrac connects to the Control Box through the tracker cable.

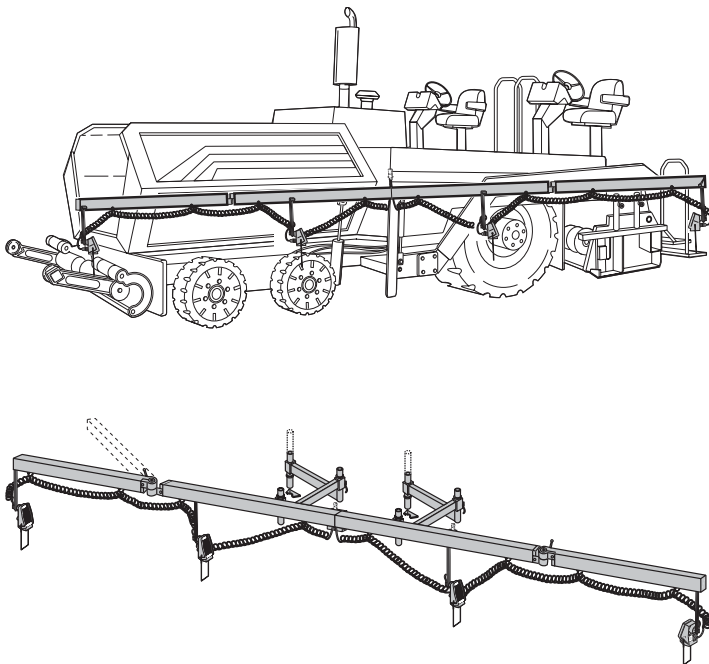

Figure 1-6. Smoothtrac Sonic Averaging System (SAS)

## Laser Tracker & Trackerjack

The laser tracker (Figure 1-7) is an elevation control sensor that measures and controls the elevation of the screed. After receiving a signal from a rotating laser, the laser tracker sends a signal to the Control Box, which then sends a raise or lower signal to the tow point cylinder.

The Trackerjack attaches to the laser receiver and then mounts to a vibration pole (Figure 1-7). Use the same cable from the Sonic Tracker II to power the laser tracker/Trackerjack system.

The laser trackerjack should be removed at the end of each day and stored in its carrying case.

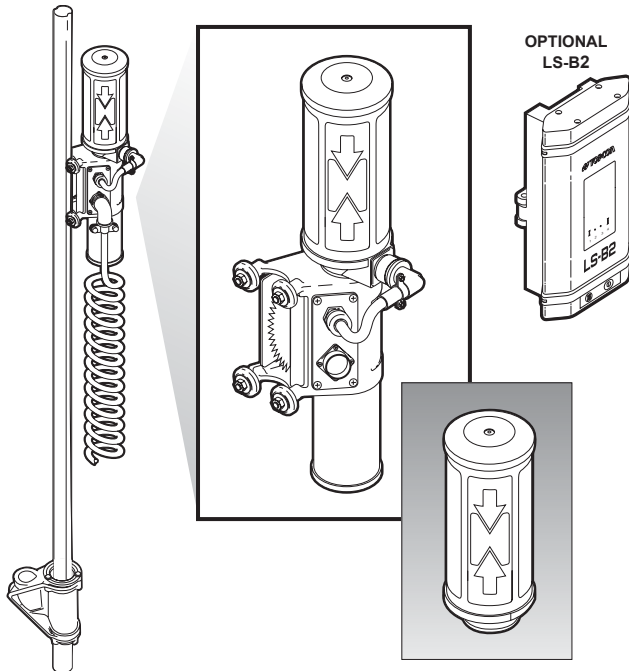

Figure 1-7. Laser Tracker & Trackerjack

## Care and Preventive Maintenance

In general, follow these guidelines when using System Five:

- Always clean and thoroughly dry the removable components before storing them in carrying cases. Use a clean, soft cloth moistened with a neutral detergent or water.
- Keep carrying cases clean and dry. Do not leave them open and exposed to the elements.
- Some moisture on the Control Box and its components is acceptable during working conditions. Do not spray water or use high pressure steam cleaner hoses directly on cables and components.
- Use protective connector caps on cables when not using the System Five for a period of time. Water accumulating on the connectors can cause electrical shorts.

At the end of the day, performing general maintenance and storing mobile parts will help to keep the System Five in top condition.

- Remove the Control Box and the Laser Tracker and dust with a dry or damp non-abrasive, soft cloth.
- Insert cables into appropriate storage connectors after removing the Control Box.

A Carrying Case is provided with each System Five. The Carrying Case is lined and includes pre-cut sections for each Sonic Tracker II and the Control Boxes. A cut-out section is also provided for storing coil cords (Figure 1-8 on page 1-9).



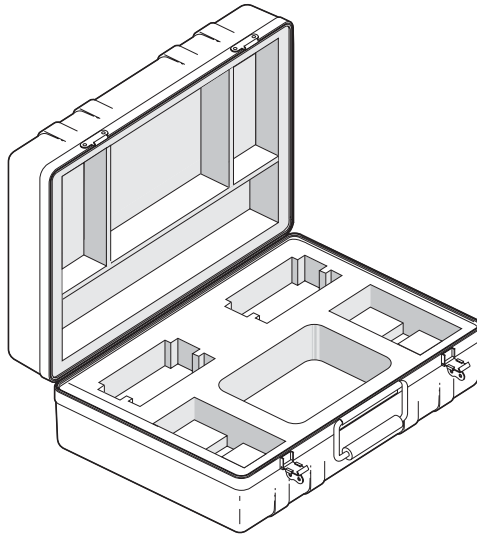

**Figure 1-8. Carrying Case**



**NOTICE**

*Keep the carrying case dry and store in a dry location. Never let the interior of the carrying case become wet. If the case does become wet, remove the components and let it dry.*



# Paving Principles & Control Methods

This chapter describes the components of pavers and the basics in paving principles, as well as control methods used for paving.

## Paver Components

Modern pavers (Figure 2-1) consist of two major units: the Tractor and the Screed.

The primary function of the tractor is to propel the truck or paver feeding device, to convey and distribute the paving material and to tow the screed. The function of the screed is to strike off the material in preparation for further compaction. The screed is mounted to the tow arms at the screed pivot points and is attached to the paver at the tow points.

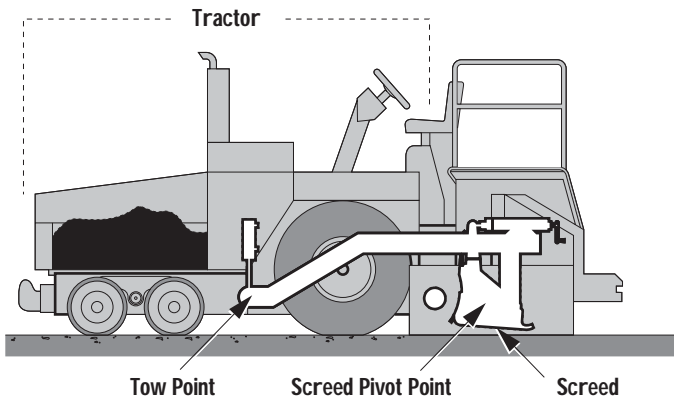
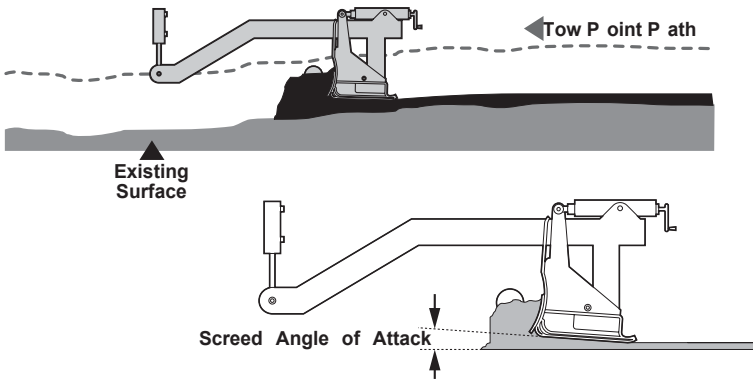

Figure 2-1. Paver Components

## How a Screed Works

The screed on all modern pavers is of the “floating, self leveling” type. As the paver tows the screed unit forward, paving material flows under the screed. This causes the screed to float on the mat of material, thus establishing mat thickness. Since the screed is mounted to the paver only at the tow points, the screed is completely free to float up or down (Figure 2-2). The screed will always seek it’s own “Planing Angle”, or angle of attack, dependent on the combination of forces acting upon the screed (Figure 2-2).



**Figure 2-2. Tow Point Path and Planing Angle**

- If the screed angle of attack is increased the screed rises, increasing the mat thickness (Figure 2-3).
- If the angle of attack is decreased, the screed will settle, providing a thinner mat surface (Figure 2-3).

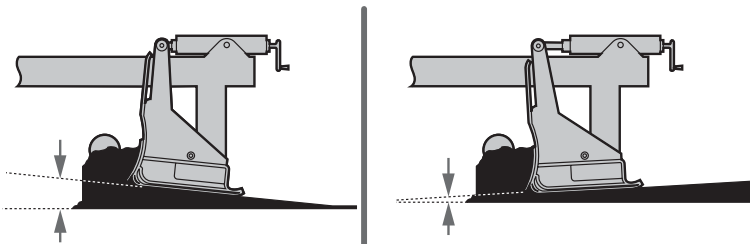
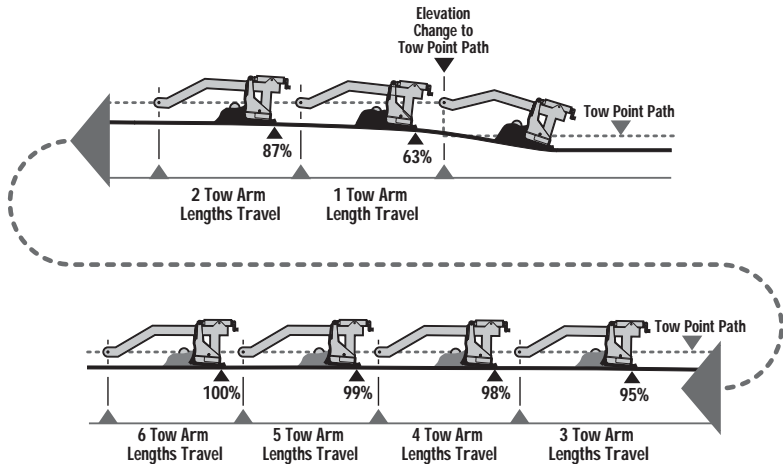

**Figure 2-3. Screed Determines Mat Thickness**

Because the screed floats, it will not immediately react to a change in the tow point. It needs a certain amount of time or distance to make a correction in the mat thickness (Figure 2-4).

- If the tow point is changed by a unit of one, the paver must move one tow arm length before the screed will correct 63% of the elevation.
- After 2 tow arm lengths 83% of the correction is made and 3 tow arm lengths would account for 95%.
- It takes 6 tow arm lengths to achieve 100% of the elevation change.

Considering that 95% of the change takes place after 3 tow arm lengths, this can be used in practical applications to qualify for full correction.



**Figure 2-4. Tow Arm Travel**

The same is true when making elevation changes with the manual thickness cranks (Figure 2-5).

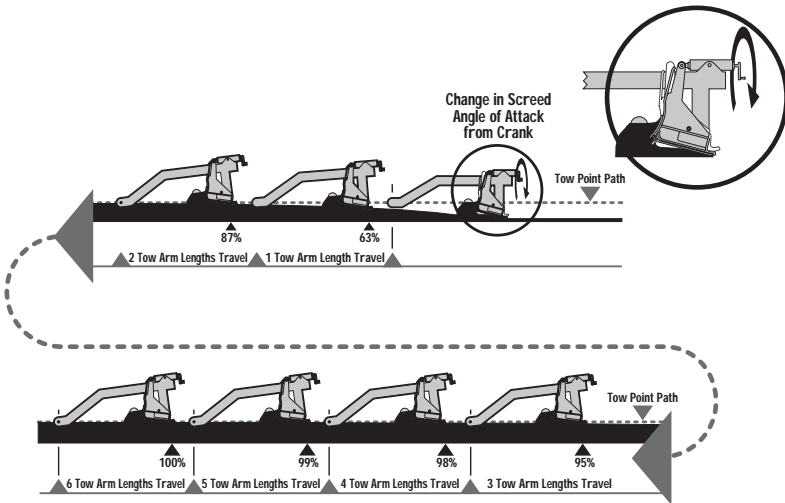

**Figure 2-5. Manually Changing Mat Thickness**

Always check mat depth in several locations before making any elevation corrections. The surface being paved may have wheel ruts, dips and ridges that will give an untrue indication of overall mat depth. Check several spots to get an average (Figure 2-6). If an elevation change is made, wait 3 tow arm lengths for full correction. Too much cranking and stabbing will cause raise and lower changes that will produce an uneven mat surface.

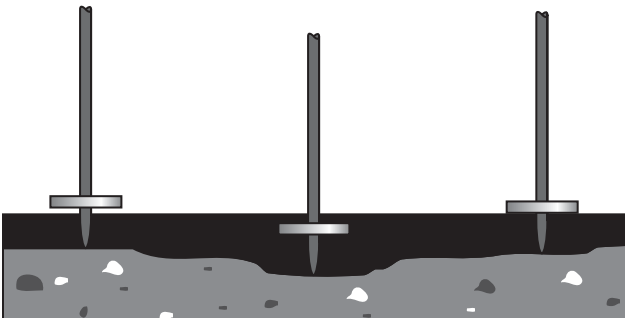

**Figure 2-6. Checking Mat Thickness**

The screed has four main forces acting on it at all times, whether paving in manual or with automatics (Figure 2-7). A change in any one of the forces will cause the screed to rise or fall, changing the mat depth. The key to smoother paving is to keep these forces as constant as possible. The following sections review these forces and the factors that will have an effect on the paving.

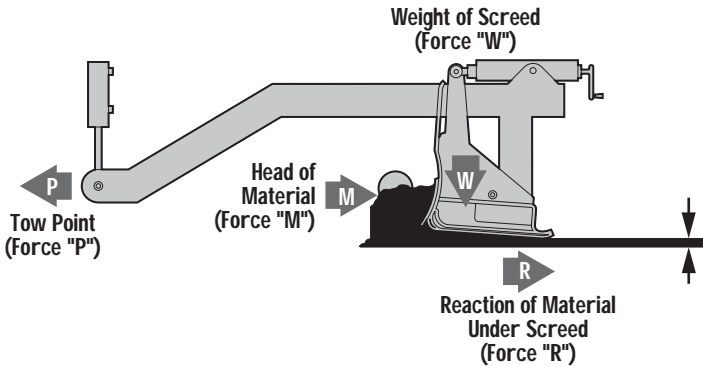

Figure 2-7. Forces Affecting the Screed

## Tow Point Force ("P")

The tow point force (P) is the resistance to forward travel (Figure 2-8).

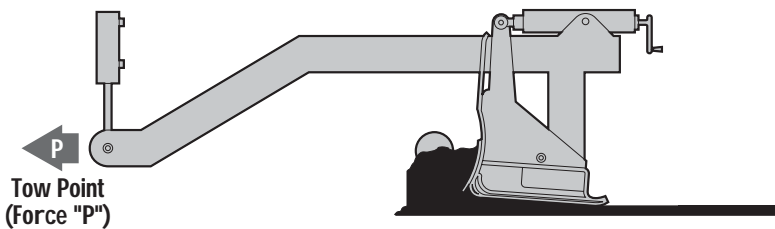

Figure 2-8. Tow Point Force ("P")

The P force will remain constant if the paver is kept moving at a consistent speed at all times. If the paver is allowed to stop, the screed will settle in the fresh mat and leave a mark. The mark cannot be fully smoothed out by the roller and a bump will end

up in the mat that will show up in the profilograph readings. Changing the speed of the paver will also cause the screed to rise and fall, affecting the mat thickness.

The optimum paving speed is determined by the depth and width being paved and the rate at which material can be delivered to the job. Calculate the tons/hour into feet per minute (Figure 2-9). Do not start and stop the paver.

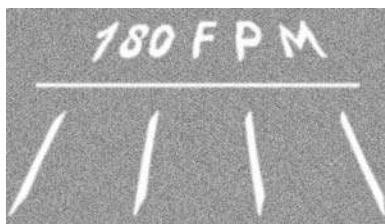

Figure 2-9. Travel Speed to Reduce Tow Point Force (“P”)

### **Truck Exchange, Another Tow Point Force**

It is very important that truck exchanges be carried out as smoothly as possible to avoid disturbing the smooth, uninterrupted forward motion of the paver. The following lists some steps to take to avoid disturbance of the paving operation by trucks.

1. Stop the mix delivery truck close, but not too short of the paver. Always allow the paver to pickup trucks on the run.
2. Never allow the truck to bump the paver. Allowing trucks to bump the paver when backing up, can drive the screed into the mat and produces bumps and ridges which may not roll out.
3. Trucks applying and holding their brakes excessively while dumping their load may cause the paver to slow, which in turn will cause the screed to rise. The truck driver should apply only light pressure on the brakes, sufficient to maintain contact with the paver.



4. Dumping of material in front of the paver as the truck pulls away after emptying its load into the hopper, can cause the paver to ride over the pile of material with subsequent adverse effects on mat quality. Avoid trucks pulling away prior to completely dumping all material. Use a dump person to monitor and regulate truck movements in front of the paver.

## Head of Material (“M”)

One of the primary functions of the paver tractor is to convey and distribute paving material onto the ground in front of the entire width of the screed. This material, once deposited in front of the screed is the head of material over which the screed will pass.

One of the keys to smooth paving is to maintain this head of material as constant as is possible. The resistance to forward motion exerted by the head of material (M) is one of the major component of resistance to forward motion (Figure 2-10). Control of this force is a basic and necessary function of any paving operation.

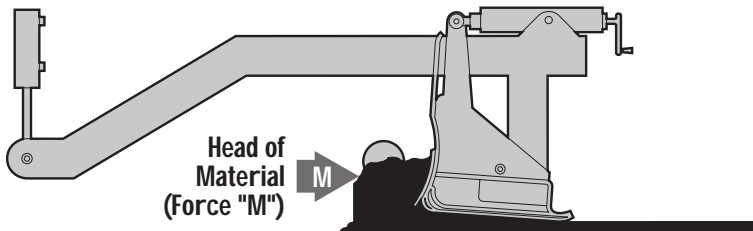

Figure 2-10. Head of Material Force (“M”)

The volume and consistency of the head of material determines how much paving material flows under the screed and influences mat thickness and surface texture.

The most common factor affecting force “M”, the head of material, is incorrectly adjusting the Automatic Feeder Controls.

These systems, whether of the “hanging paddle” type or the sonic sensor type, should be adjusted to operate the auger/conveyor assemblies 95% to 100% of the time. On/off operation of the auger system will cause fluctuation in the head of material.

The highest quality mat will generally result when a constant head of material is maintained across the entire width of the screed and the material almost covers the auger shaft. If the volume of paving material is too high, there is resistance to the travel of the screed. This causes the screed to rise and can result in ripples, auger shadows and long waves. It also results in increased auger wear (Figure 2-11).

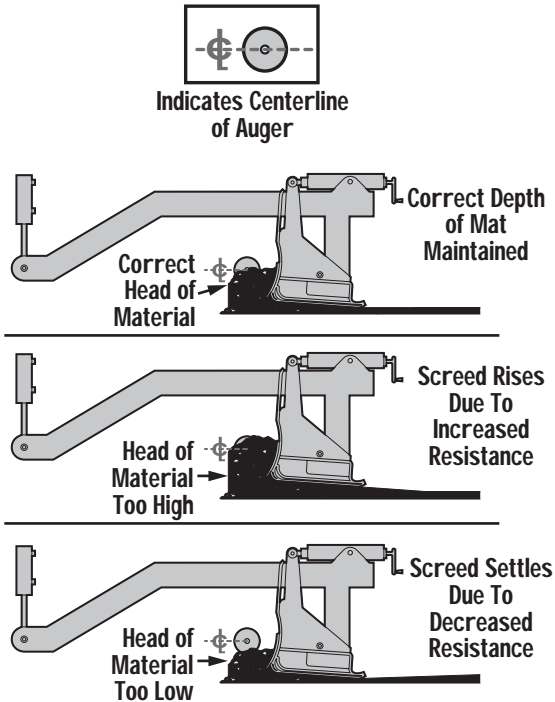

Figure 2-11. Head of Material Affects Mat

## Reaction of Material Under Screed (“R”)

Ideally, every truck load of material delivered to the paver would be exactly like every other load, with no variation. However, as a practical matter, changes in mix characteristics such as mix temperature, density, gradation, A.C. Content, segregation, etc., will affect the internal stresses developed within the mix, which in turn affects the resistance of the mix to flow under the screed (reaction of material under screed, “R”). The key element to bear in mind is that the screed passing over the paving material will compact the material to a certain degree. Variables in the resistance of the material to compactive forces will cause changes in the screed's angle of attack, which in turn will affect mat thickness and therefore mat smoothness (Figure 2-12).

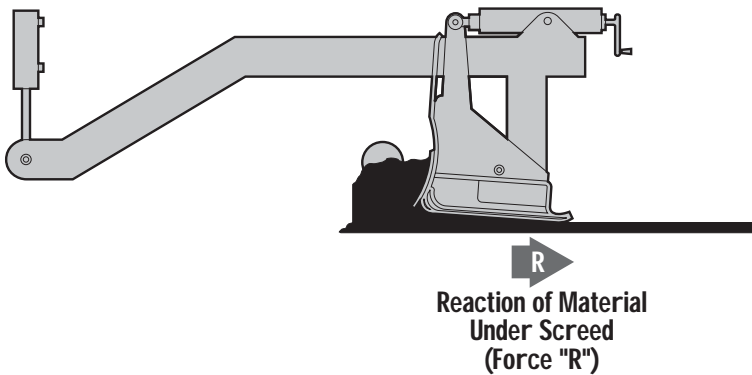

Figure 2-12. Reaction of Material Under Screed

### Gradation Mix Characteristics

This aspect of the paving material will vary according to the intended use of the material as abase course, binder course or the final wearing surface. Normally, maximum aggregate size, ratio of aggregates, fines content and most importantly, asphaltic binder content, is specified by the contracting agency.

Adherence to mix design specifications is usually the responsibility of the material supplier.

Segregation is a material deficiency caused by a separation of the larger aggregate sizes from the bulk of the paving material.

This condition is encountered especially in mixes with relatively large maximum size aggregate (example: 1" and larger, the so called "large-particle" mixes). When paving material is deposited in piles, as in an asphalt plant silo, a haul truck, a paver hopper, on the ground in front of the paver in a windrow, or on the ground in the auger chamber, segregation can and does frequently occur.

 **NOTICE**

*The areas listed above where segregation can occur are all areas that the material may encounter before being laid down as a mat. Therefore, these areas of segregation must be addressed prior to any paving. The screed cannot rectify segregation during the paving process.*

Segregation can also be the result of improper hopper dumping.

During normal operation, the vibration of the pavers hopper will cause segregation. Therefore, dumping the hopper after each truck should be avoided because material that has rolled to the outside of the hopper (the large aggregate) will fill the conveyors and auger chamber and result in a segregated area behind the paver with a noticeable difference in surface texture.

**If It Doesn't Look Right, It Isn't Right:** Surface and texture irregularities indicate that the homogeneous characteristics

of the material in the mat have been interrupted, which usually results in bumpiness and premature failure of the pavement in those areas.

Segregation can also be the result of excessively worn augers: “Center Streak” segregation can be caused by worn “Kicker Paddles” at the center chain cause or near the outside auger bearings. In fact center streak segregation is frequently caused by incorrect arrangement of the auger segments adjacent to the auger chain case. (Consult the Manufacturers Manual).

“Center Streak” segregation is also caused by feeder gates being set to tow. Adjust as necessary to provide sufficient uniform material at the center of the paver.



### NOTICE

*“Center Streak” segregation can be limited and even eliminated by slowing paving speed.*

### **Mix Temperature Characteristics**

A common paving problem is inconsistent temperatures in the asphalt mix. As the material cools it loses its viscosity making it more difficult to compact. If the resistance to compaction increases, the screed will naturally increase its angle of attack and begin to float up. This will change the mat depth, resulting in bumps in the surface. If the mix and or screed temperature are too low, the screed may no longer slide smoothly over the material and a tearing of the mat will occur.

#### Simple steps to take to control temperature variations:

1. Ensure that haul trucks take the shortest, most practical route to the paver. Make certain that all trucks take the same route to the paver.

2. Make sure that the trucks arrive at the same order in which they were loaded at the asphalt plant.
3. Ensure that no bunching of trucks occurs at the paver, with several trucks waiting to dump their loads.
4. Match lay-down rate to material delivery rate.

**NOTICE** NOTICE

*Temperature problems may occur will before the time the material is loaded into the trucks, or during the trip to the paver. They can be the result of temperature variations at the plant. If this is not addressed prior to delivery of material to the paver, waviness in the he mat will be the result.*

**Weight of Screed (“W”)**

For the weight of screed force “W” to remain constant, the weight of the screed or the downward pressure exerted by the screed on the paving material should not change (Figure 2-13). The weight of the screed is measured in pounds per square inch.

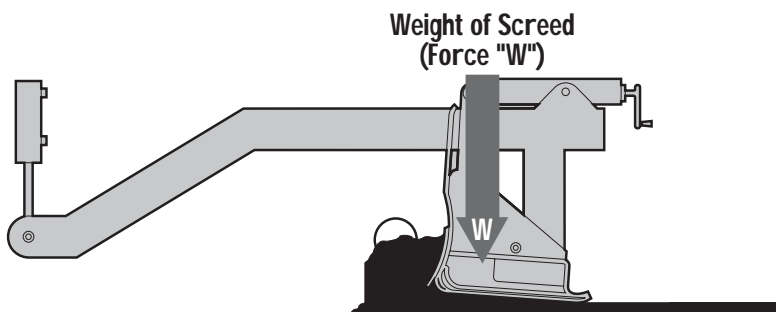

**Figure 2-13. Weight of Screed**

Members of the paving crew climbing on and off the screed will also have some affect on the weight of screed force.

The primary factor affecting this force is changing the width of the screed (Figure 2-14). Extendible screeds weigh the same whether they are fully retracted or fully extended. The difference is the wider the extension of the screed the greater the surface area of paving material to support. An extended screed has fewer psi, which means less compaction, causing the screed to raise.

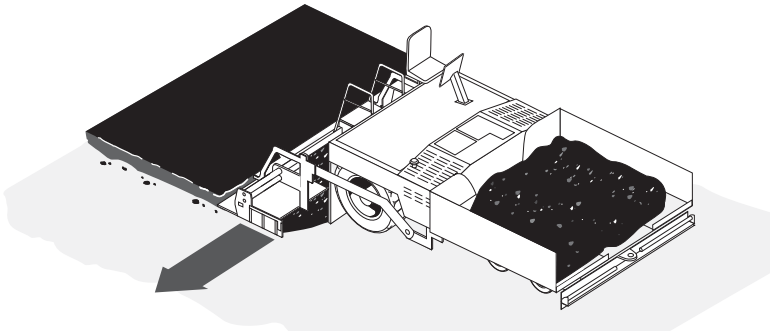

Figure 2-14. Width of Screed Affects Weight of Screed

## Quality of Base Being Paved

There are factors other than the four main forces that can have an effect on the quality of the mat. An important one is the quality of the base to be paved. It makes more sense to build smoothness from the base up, than to try to smooth a road in the last lift of paving. However, on overlay paving jobs we have to work with what we have.

Remember that a mat which appears smooth immediately behind the paver, may actually contain areas of considerably varying thickness of material as a result of undulations in the base being paved. Due to the principle of “Differential Compaction” high spots will not compact as much as the low, therefore allowing some of the irregularities to be rolled back onto the mat (Figure 2-15 on page 2-14). To minimize this problem, lay a leveling course in the low spots or pave multiple lifts to average out the irregularities.

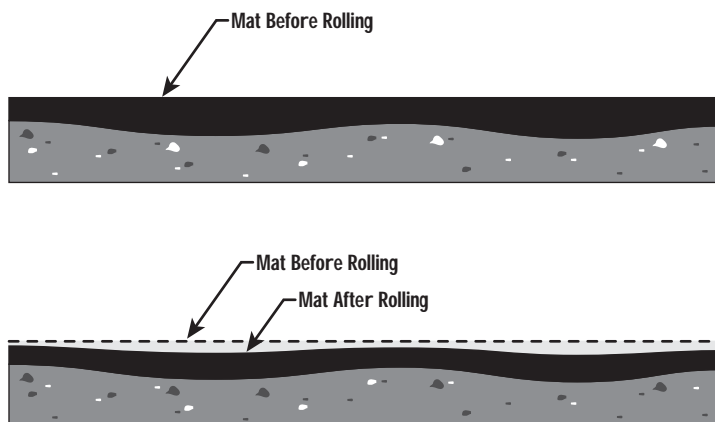

Figure 2-15. Differential Compaction

### Rolling Techniques

A well laid mat can end up with a poor ride quality if proper rolling methods are not followed. Consult your compaction equipment manufacturer's manuals and handbooks on compaction techniques.

### Controlling Mat Quality

The primary purpose of the asphalt paver is to place a smooth mat of material. The primary function of System Five is to control the vertical position of the screed in relation to the surface being paved. Automatic grade and slope control systems can help tremendously in controlling mat smoothness but mat quality is also dependent on the following factors:

- Non-stop, continuous operation of paver
- Constant speed of paver
- Truck exchange
- Head of material



- Mix characteristics
  - Gradation
  - Segregation
  - Mix Temperature
- Screed Compaction
- Quality of Base Being Paved
- Rolling Techniques



### NOTICE

*Changes in any of these factors will cause a change in mat thickness, density, surface appearance and mat quality. If changes must be made, make them as gradually as possible. Abrupt changes in any of the above factors will produce rapid changes in mat thickness, adversely affecting mat quality.*

## Control Methods

The following sections describe the three types of control possible with the Pave System Five: sonic, laser, and slope.

### Sonic Control

The Sonic Tracker II™ measures and controls the elevation of the screed, controlling grade from a physical grade reference, such as a curb, stringline, or existing road surface.

A transducer, located in the bottom of the Tracker, generates 39 sound pulses per second and listens for returned echoes like a microphone. As soon as the Tracker sends out a sound wave, it starts a stop watch. The sound waves go down, bounce off of a physical reference, and reflect back to the Tracker. The Tracker measures the time it takes for the sound wave to return to the

Tracker. Knowing the speed of sound, the Tracker accurately calculates the exact distance to the grade reference (Figure 2-16).

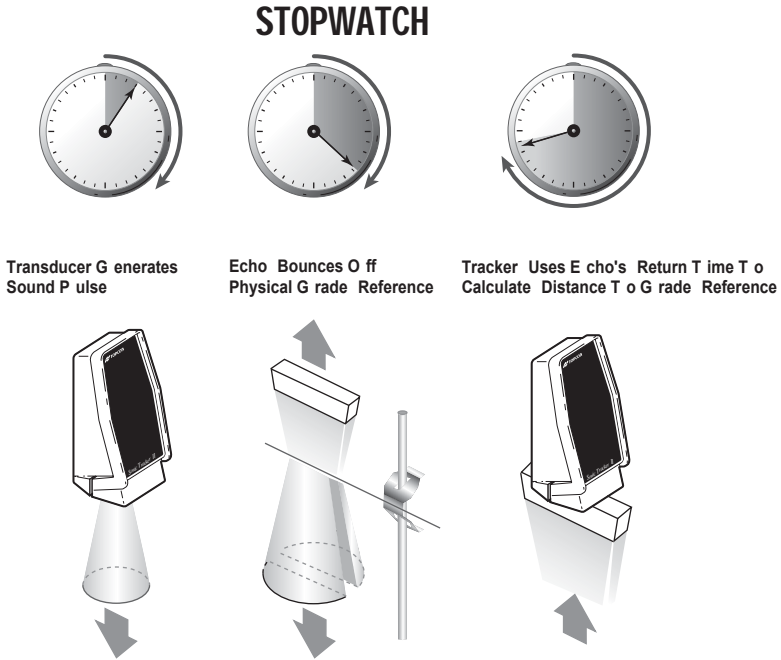
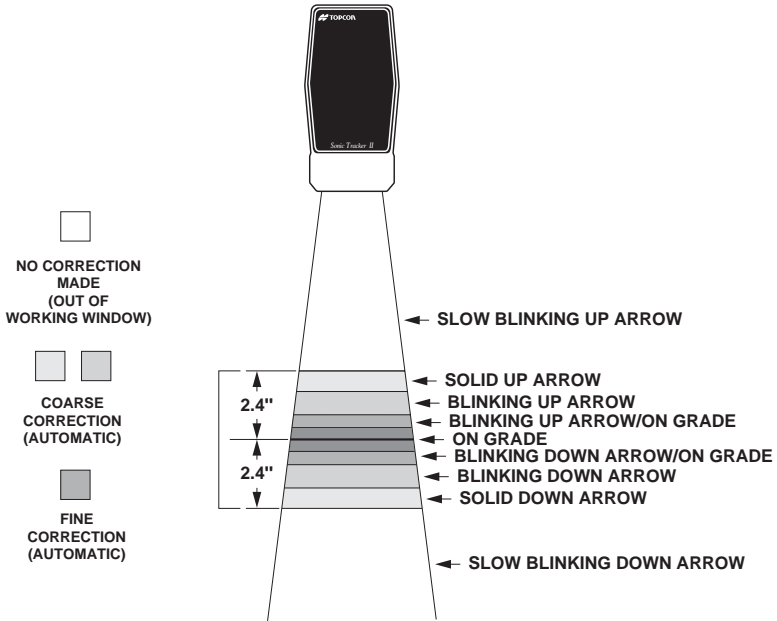

Figure 2-16. Timed Sound Pulses Determine Distance

### Working Window and Sonic "Footprint"

Built into the Tracker is an operational zone, or Working Window, 2.4 inches above and below the grade reference (Figure 2-17 on page 2-17). The grade lights on the Sonic Tracker and Control Box continuously display this grade information to the operator.



**Figure 2-17. Sonic Tracker Working Window**

When setting up the Tracker over a grade reference, the size of the Sonic Cone or the “footprint” needs to be considered (Figure 2-18 on page 2-18). As an example, at about 2 feet from the tracker, you will have a footprint or cone of about 6 inches.

As the Tracker is positioned closer to the grade reference the working footprint decreases in size. As the Tracker is moving farther away from the grade reference the sonic footprint or cone will increase in size.

### SONIC "FOOTPRINT"

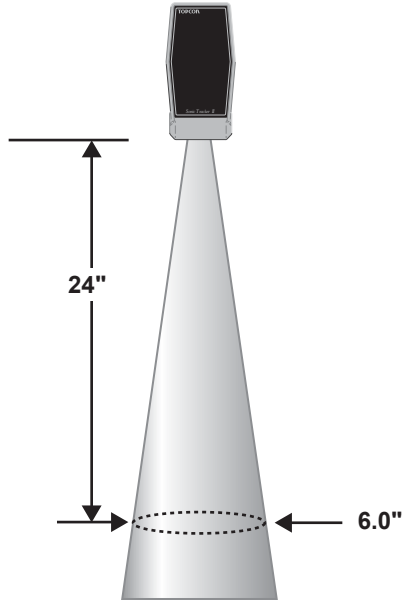
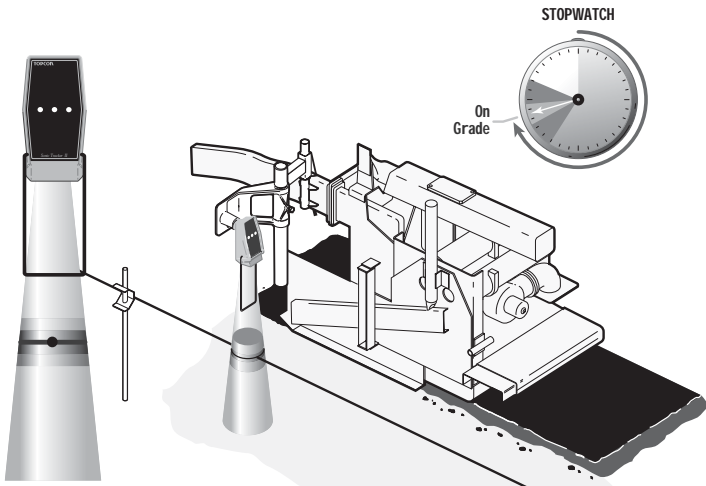

Figure 2-18. Sonic Tracker "Footprint"

### Sonic Tracker Operation and its Position

On the paver, the Sonic Tracker II will be positioned above the grade reference to maintain an exact distance from the tracker to the reference (Figure 2-19 on page 2-19). If the Tracker is on-grade, the mat being laid will be at the desired depth.



**Figure 2-19. Sonic Tracker On-Grade**

If the screed and the Sonic Tracker II start to raise, the watch stops at a longer time (Figure 2-20). The Tracker and Control Box will indicate a down correction arrow, and lower hydraulic valve corrections are applied to bring the Tracker back to on-grade.

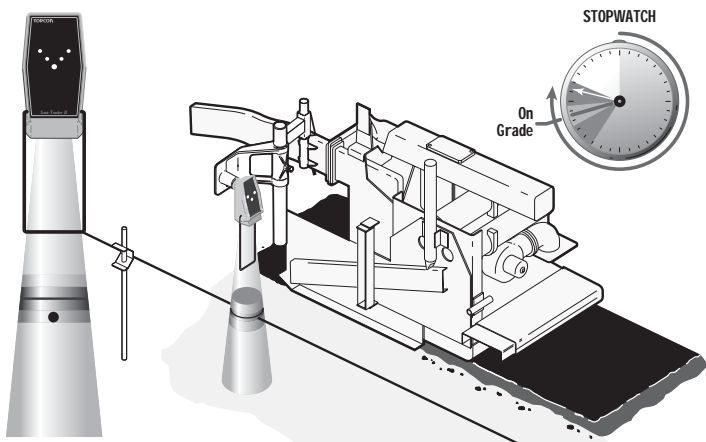

**Figure 2-20. Sonic Tracker above Grade**

If the screed and Sonic Tracker II are lowered, the watch stops at a shorter time (Figure 2-21). The Tracker and Control Box indicate a raise correction arrow, and raise hydraulic valve corrections are applied to bring the Tracker back to on-grade.

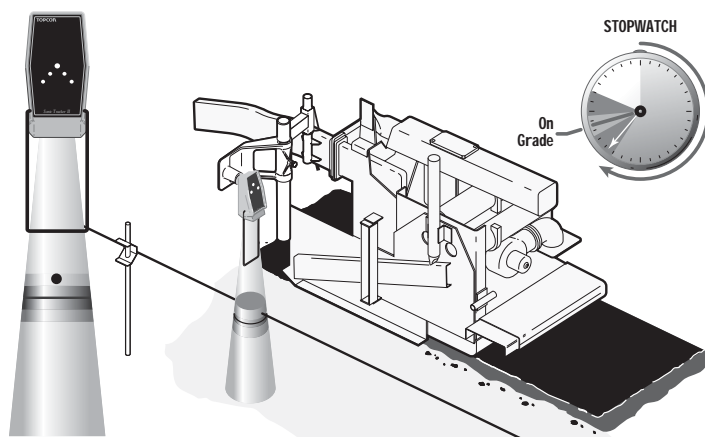

**Figure 2-21. Sonic Tracker Below Grade**

If the Sonic Tracker II is side shifted off a stringline, the sound waves reflect off the ground and the Tracker's stopwatch indicate a longer time (Figure 2-22 on page 2-21). The Tracker is out of the Working Window, and no on-grade corrections are applied.

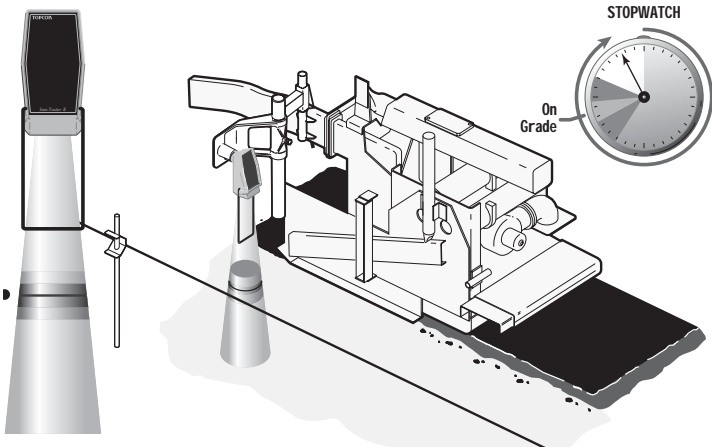

**Figure 2-22. Sonic Tracker Scanning Outside of Stringline**

If the Tracker sees an obstruction closer than the reference signal, such as a grade pin, the watch stops at an even shorter time (Figure 2-23). The Tracker is out of the Working Window, and no on-grade correction signals are applied.

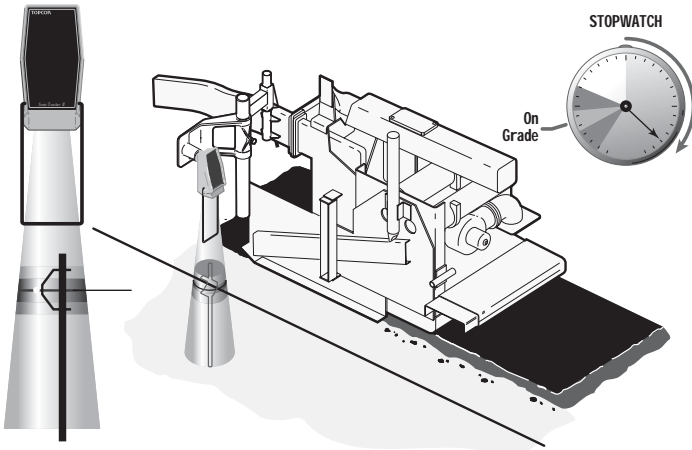

**Figure 2-23. Obstructions within the Sonic Tracker's Working Window**

## Sonic Tracker and Temperature Changes

Since temperature affects the speed of sound, the tracker has a built in temperature sensor for applications with gradual temperature changes such as on graders or dozers. In paving applications you can get a more dramatic and rapid change in air temperature. To compensate for these variations a temperature bail is positioned below the tracker.

When the Sonic Tracker's transducer emits a sound wave, the tracker records the time to the bail and continues to listen for the grade reference. If a temperature variation occurs, such as heat off a freshly paved mat, a difference in time to the temperature bail is recorded. The correction for the speed of sound is then applied to the grade reference signal, preventing a change in mat depth. The tracker corrects for temperature variations with every sound wave, 39 times per second. Figure 2-24 illustrates this concept.

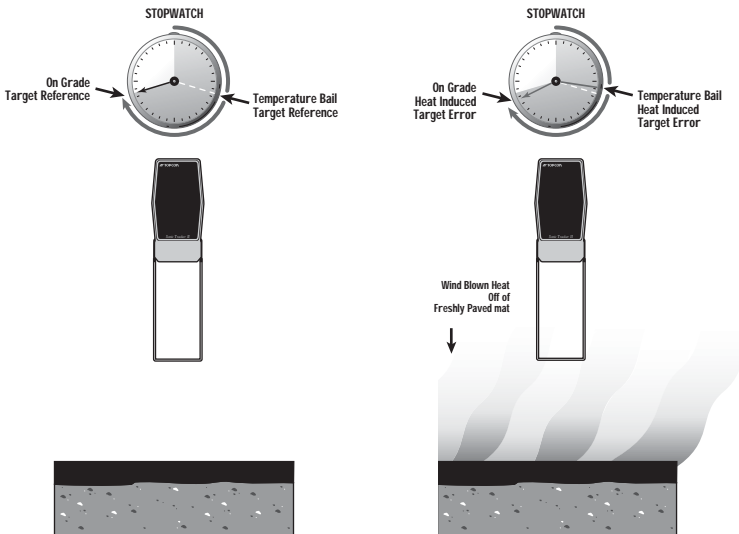
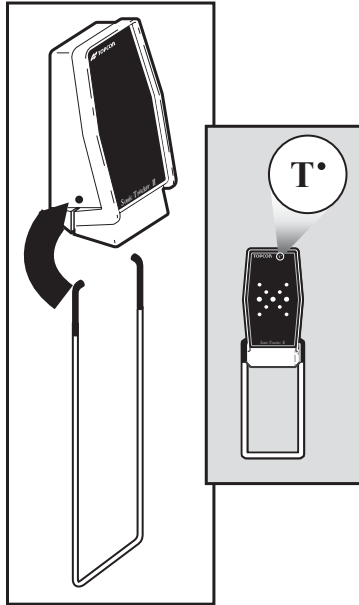

Figure 2-24. Working with Sonic Trackers and Temperature Changes



In the upper right hand corner of the Sonic Tracker II faceplate is a small symbol used to represent the use of the temperature bail. The LED symbol automatically illuminate when the bail is connected to the tracker. The tracker is cast with holes on each side for the bail to snap and lock into place (Figure 2-25).



**Figure 2-25. Sonic Tracker and Components**

## Laser Control

For Laser Control a laser transmitter is used to produce a plane of light which becomes the grade control reference for the job site. The laser receiver will control the screed to lay a mat parallel to the laser beam reference.

When the laser beam is in the center of the receiver, it indicates an on-grade signal (Figure 2-26).

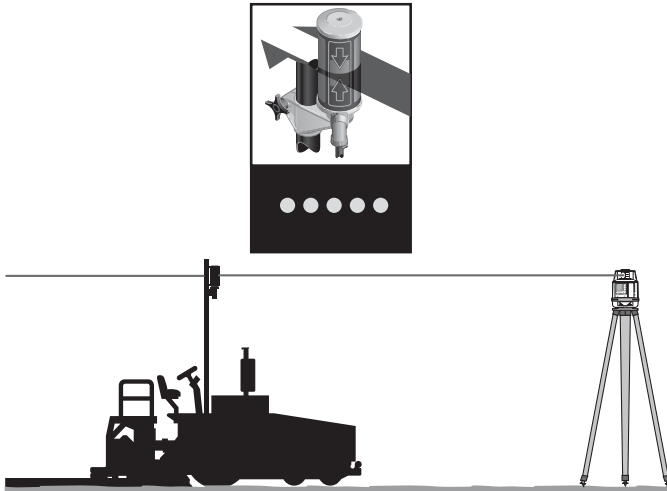
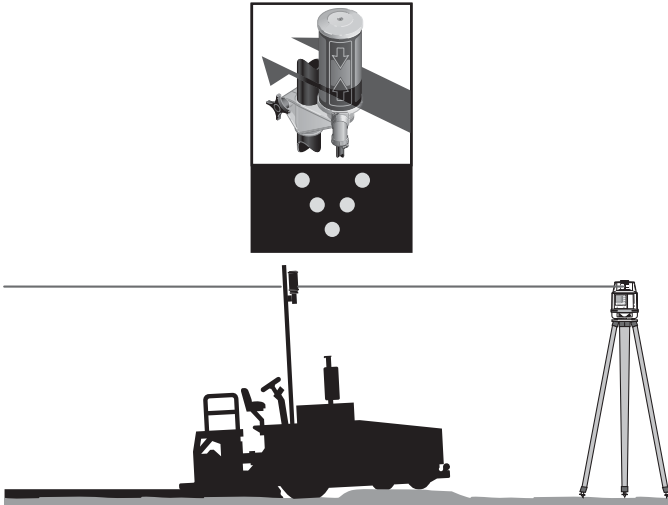

Figure 2-26. Laser Control – On-Grade

As the screed is raised, the beam of light hits the laser receiver below the center and a lower signal is indicated (Figure 2-27 on page 2-25).



**Figure 2-27. Laser Control – Above Grade**

As screed is lowered the beam of light hits the Laser Receiver above the center a raise signal is indicated (Figure 2-28).

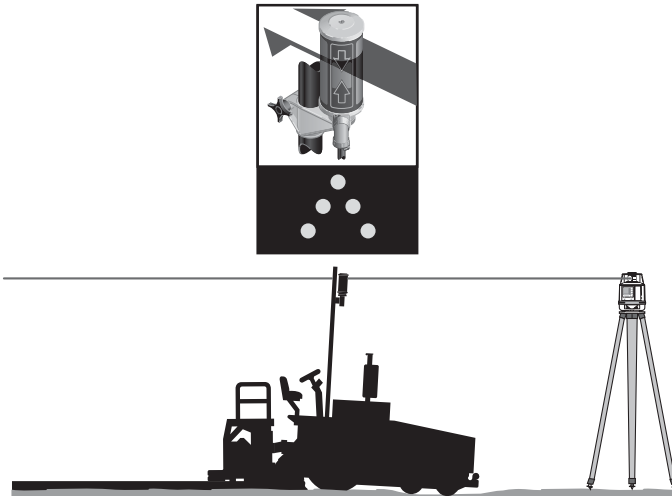

**Figure 2-28. Laser Control – Below Grade**

## Slope Control

System Five uses a slope sensor mounted to the transducer beam on the paver to measure and control the slope of the mat being laid (Figure 2-29). The sensor contains an electronic level vial, that acts as a “precision carpenter’s level”. Slope control with this electric level vial is very accurate and repeatable.

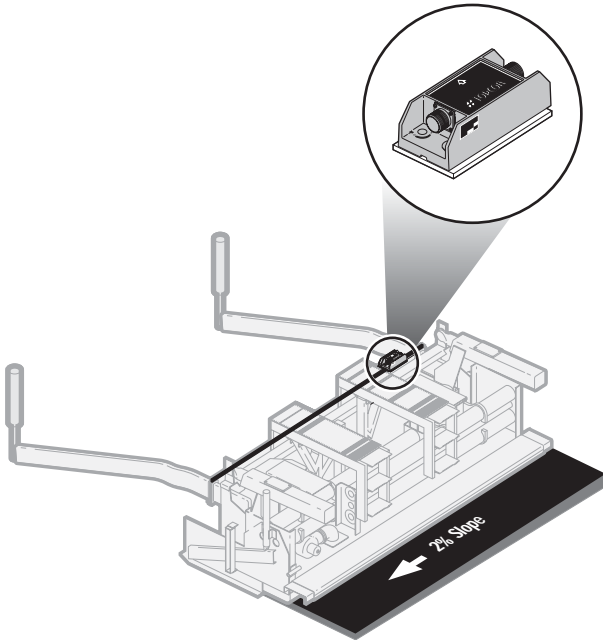

Figure 2-29. Position of Slope Control on Paving System

If the required slope changes, the screed operator dials the new slope into the System Five Control Box (Figure 2-30). The tow point cylinder on the slope side will raise or lower until the slope sensor measures the new slope.

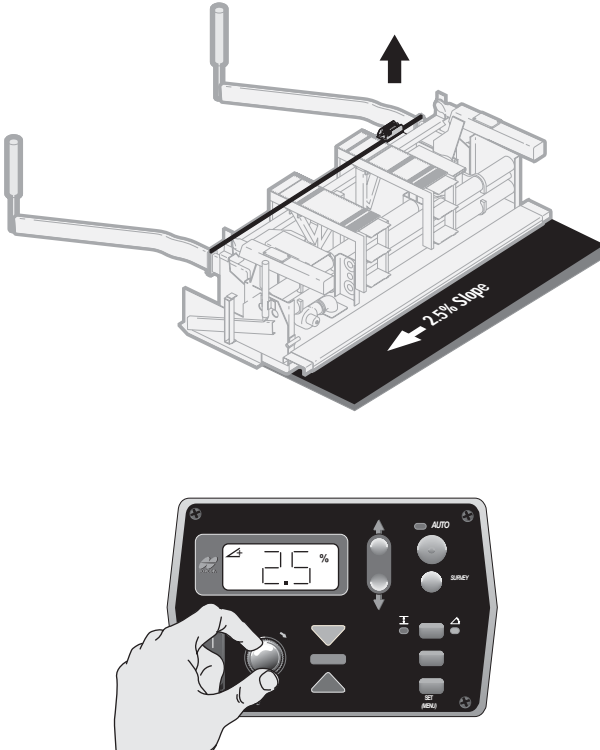

Figure 2-30. System Five Box directing the Slope Sensor position

# Notes:

---

---

---

---

---

---

---

---

---

---

---

---

---

---

---

---

---

---

---

---

---

---

---

---

---

# Stringline Setup

Sonic Stringline provides an inexpensive, easy to set up, continuous reference that takes the best advantage of the non-contacting feature of the Sonic Tracker II™. Stringline takes a few minutes to setup, and becomes a constant grade reference. The stringline also becomes a visual reference for the job, allowing any mistakes in a hub elevation to be quickly spotted by sighting down the string.

Sonic stringline is both a reference and an averaging solution.

- As a reference, surface and elevated stringline provides consistent results for level and sloped surfaces.
- As an averaging solution, surface stringline takes the place of averaging skis.

The sonic stringline setup consists of readily available materials and up to 500 feet of nylon stringline. Topcon's Sonic Tracker II works with many sizes and types of stringline, for best results use an 1/8 inch diameter nylon stringline.



## NOTICE

*Using steel wire or a plastic coated stringline with a smooth surface can provide erroneous results.*

For a review of how the Sonic Tracker II works, see “Sonic Control” on page 2-1. If the Sonic Tracker tracks the ground but not a 1/8 inch diameter stringline, clean or replace the transducer. See Chapter 7 for this procedure.

## Setting Surface Stringline

Surface stringline provides a low-impact reference and averaging solution for steering and grade control. Because it rests close to the surface, trucks and other traffic can drive over the stringline without causing control problems and reference damage.

As a grade reference, Pavers use the Sonic Tracker II to track the stringline, producing a consistent and constant cut. When sighting down the stringline, problem areas can be spotted, and marked or fixed, before paving begins.

Surface stringline replaces a contacting averaging ski when a reference is unavailable or impractical. Averaging skis average out the irregularities of the surface being cut, but can be impractical, bulky, complex, and fragile. Surface stringline is simple, more practical, and easier to maintain than an averaging ski. When stretched over the ground, surface stringline levels the high places and bridges the low (Figure 3-1), creating a natural average over a distance as long as 500 feet.

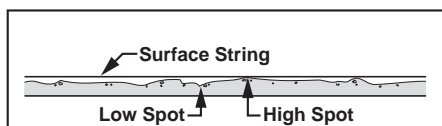

Figure 3-1. Surface String Averaging

Surface stringline is a verifiable reference for any job, replacing cumbersome averaging skis. In coordination with the Sonic Tracker II, stringline acts as 5 to 500 foot long, virtual, and more accurate, averaging ski.

Sometimes, the surface to be milled contains pot holes or surfaces too broken to use as a joint match reference. Setting elevated stringline would be too time consuming, especially for small, divided projects. In these applications, surface stringline provides a simple, easy alternative.



Position the tracker 14 to 18 inches above the stringline (Figure 3-2).

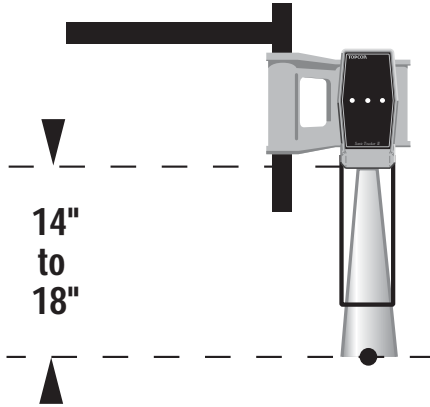

Figure 3-2. Position of Tracker in Correlation to Stringline



### NOTICE

*It is important to use a stringline with a diameter at least 1/8" thick. The sonic tracker can detect a smaller diameter stringline, but when stretched on the surface to be paved the surface below the stringline will be within the working window so you want to make sure you have a strong return signal.*

To setup surface string in two simple steps:

1. Drive a concrete nail into the existing surface to be cut (Figure 3-3) and tie the stringline to the concrete nail.

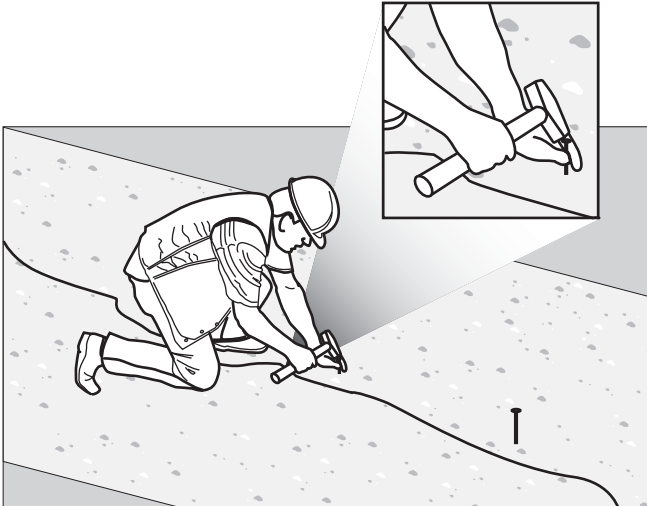

**Figure 3-3. Setup Concrete Nails**

2. Roll out the stringline to the desired length. Pull tight and secure to another nail at the opposite end. The tightened stringline rests on top of the existing surface (Figure 3-4).

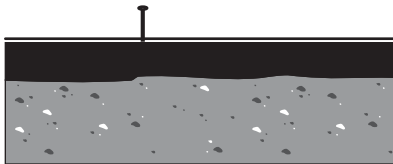

**Figure 3-4. Stringline Reference**

- When the sonic tracker sends out a sound wave, the first thing the tracker sees will be the reference stringline.

- Since the stringline is pulled tight, any small irregularities in the existing surface will be spanned (Figure 3-5).

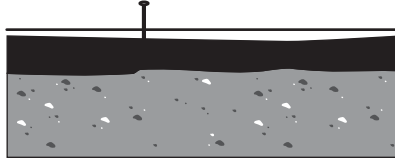
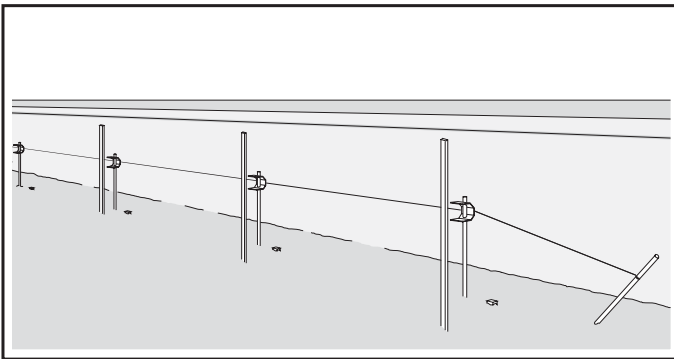

**Figure 3-5. Stringline Spans Surface Irregularities**

As a verifiable grade reference, potential problems can be pointed out to the inspector before paving.

## Setting Elevated Stringline

On some projects the asphalt must be laid to a specified elevation. For this application an elevated stringline must be set. Elevated stringline is positioned 1–2 feet above the finished grade using referencing hubs or lath placed by the surveyor (Figure 3-6).



**Figure 3-6. Elevated Stringline**

Once positioned, the Sonic Tracker II tracks the stringline, providing a verifiable slope and cut reference.



### NOTICE

*Do Not disturb the hubs.*

Your local Topcon dealer carries the following supplies for setting elevated stringline:

- Sonic Stringline, 1000' roll (p/n 7020-0101)
- Sonic Grade Clips, box of 100 (p/n 7020-0121)
- Cut/fill Offset Tap, feet/tenths (p/n 7000-1026)
- Cut/fill Offset Tap, metric (p/n 7000-1027)

Although Topcon's Sonic Tracker will work with many sizes and types of stringline, for best results use an 1/8 inch diameter nylon stringline. Using steel wire or a plastic coated stringline with a smooth surface can cause erroneous results.

1. Place the Sonic Grade Clips on stakes and drive the stakes approximately 6 to 8 inches away from, but in line with, the hubs—Do Not disturb the hubs (Figure 3-7).

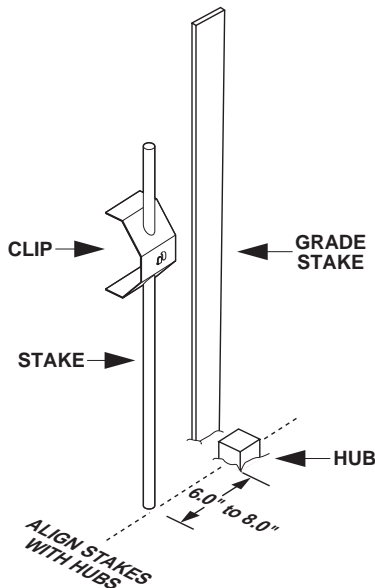

Figure 3-7. Place Clips and Position Stakes

2. Using an anchor pin at each end, roll out the Sonic Stringline the length of the working area and pull the stringline tight.

- After the stringline has been pulled tight, place it into the “fingers” of each Sonic Grade Clip (Figure 3-8).

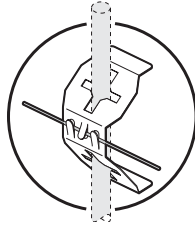

Figure 3-8. Place Stringline in Clip

- Decide what the Sonic Stringline hike-up (the distance from Finished Grade to the Sonic Stringline) should be; in this example, two feet.

## Making a Cut/Fill Lath

Once you have the stringline setup, fine-tune the height of the stringline above the grade. To do this, make a cut/fill lath using a lath and a Topcon Cut/Fill Decal.

- Assemble the required number of laths for the job.
- Measure from the bottom of the lath to the desired height above grade, and make a mark at that point. Place the Cut/Fill Decal on the lath with “0” at the marked point (Figure 3-9).

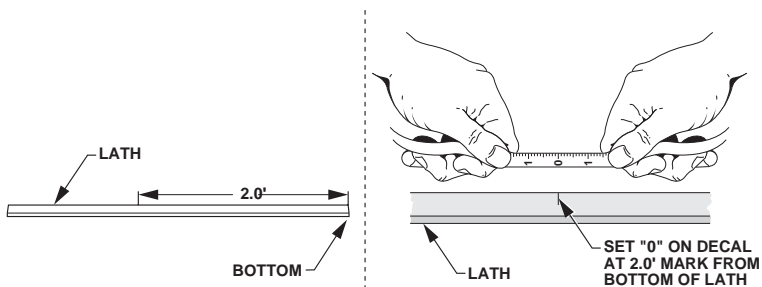
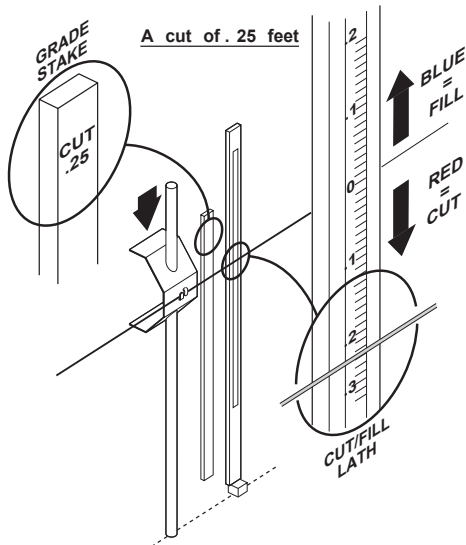

Figure 3-9. Measure Height Above Grade and Place Cut/Fill Decal

- Set the cut/fill lath on the hub and read the cut or fill from the grade stake next to the hub. Adjust the clip up or down until the stringline crosses the cut/fill lath at that point (Figure 3-10).



**Figure 3-10. Adjust Clip and Stringline to Desired Cut/Fill**

The stringline is now set to 2 feet above finished grade.

- Repeat step 3 on page 3-8 at each station before starting to cut (Figure 3-11).

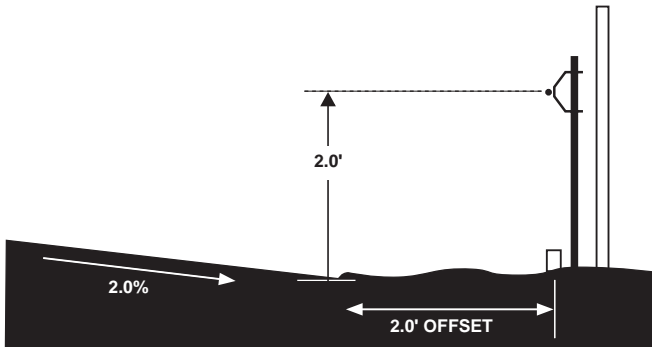

**Figure 3-11. Stringline Set at Desired Elevation**

## Attaching Stringline to the Grade Stake

Some jobs may require the stringline to be secured directly to the grade stake rather than attached to the clip.

1. Mark the lath with the desired “hike-up” above grade (Figure 3-12).

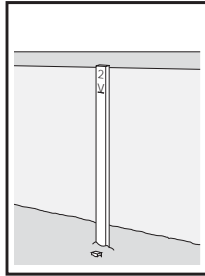

Figure 3-12. Mark Lath with Hike-up Height

2. Secure an anchor pin at each end of the stringline and pull the stringline tight.
3. At each station, staple or Ty-Wrap the stringline directly to the witness lath at the desired “hike-up” (Figure 3-13).

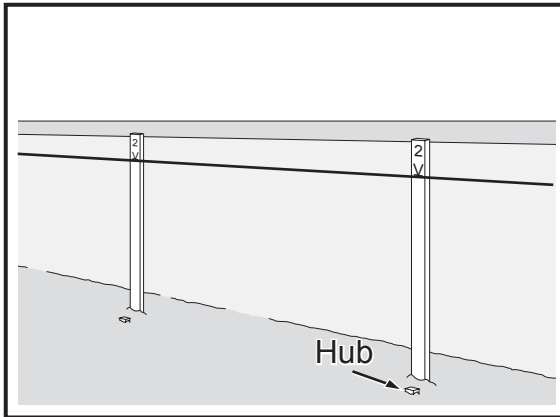

Figure 3-13. Stringline Attached to Lath

4. Due to the height of some stakes, raise the Tracker or cut off the tops of the stakes.

## Setting Projected Slope Stringline

Jobs with slope transitions or super-elevations will have the stringline set to the “projected slope.” As the profiler cuts, the Sonic Tracker and mill follow the slope of the job, preventing elevation errors at the edge of the road as the slope changes.

To set the stringline to the projected slope,

1. Set up the string at the desired elevation as shown in “Setting Elevated Stringline” on page 3-5.
2. Raise or lower the stringline to compensate for the percentage of slope and the distance from the edge of the road to the stringline:

$$\text{Rise} = \text{Run} \times \text{SlopePercentage}$$

- If the road rises away from the stringline, the stringline will need to be lowered (Figure 3-14).

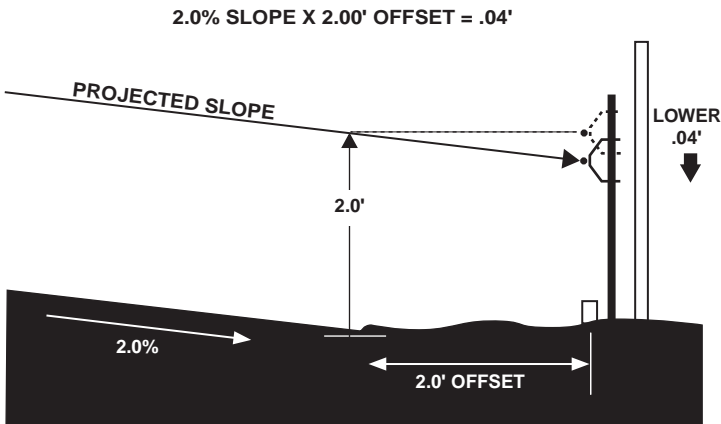

**Figure 3-14. Lower Stringline: 2% Cross Slope with 2 Foot Offset**



- If the road slopes down from the stringline, the stringline will need to be raised (Figure 3-15).

$$3.0\% \text{ SLOPE} \times 2.00' \text{ OFFSET} = .06'$$

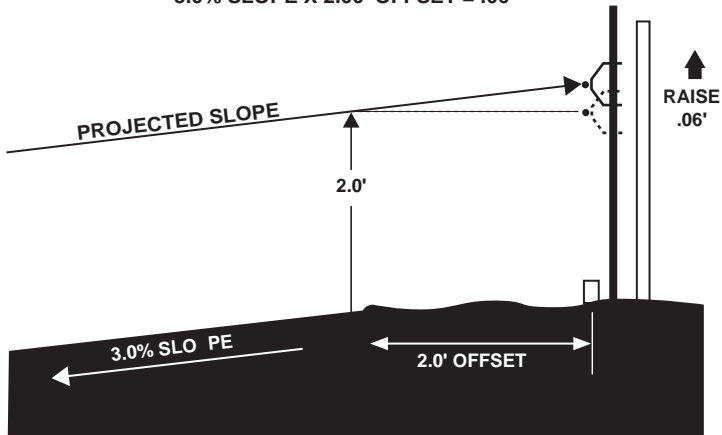

Figure 3-15. Raise Stringline: 3% Cross Slope with 2 Foot Offset

3. Repeat step 2 for each station.

## Verifying Grade

Verifying grade requires measuring the distance from the cut ground to the Sonic Stringline. To check grade, use a Grade Checking Lath to check the levelness and depth of cut with the Sonic Stringline.

The following figures show an example of a hub offset of 1.5 feet from the edge of the road, and a hike-up of 2.0 feet.

1. Construct a Grade Checking Lath using a lath, a level bubble, nails, and standard hand tools as shown in Figure 3-16.

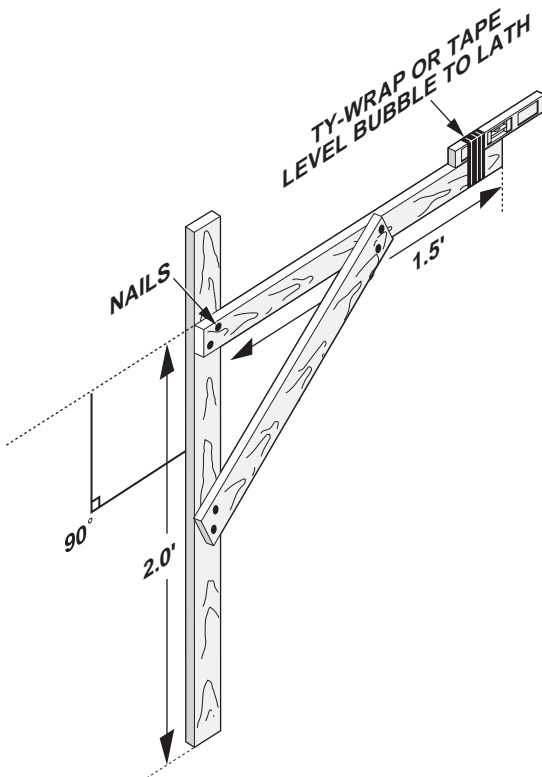
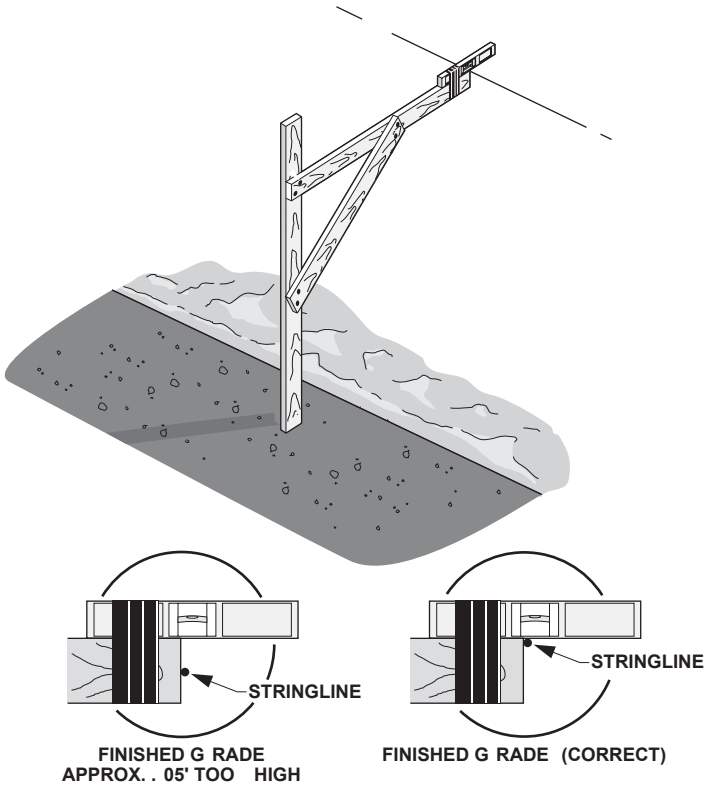

Figure 3-16. Grade Checking Lath

- Set the Grade Checking Lath on the edge of the newly cut ground so the level bubble extends over the Sonic Stringline (Figure 3-17).



**Figure 3-17. Check Finished Grade**

- Tilt the Grade Checking Lath to center the level bubble. Finished grade is correct if the level just touches the Sonic Stringline (Figure 3-17).



# Operation & Menu Settings

System Five™ uses a Control Box and Sonic Trackers to produce exceptional paving solutions. This chapter describes using the various components, including:

- The buttons, knobs, and switches on the Control Box.
- How to change settings, access information, and take readings using the various buttons, knobs, and switches.
- The menus available in the Performance Menu.
- How to access, change settings, and apply features using the Performance Menu.
- How the Sonic Tracker II™ works.



## NOTICE

*When operating in rainy weather or in wet conditions, the Control Box, Sonic Tracker II, and cables must be thoroughly dried BEFORE placing them in the Carrying Case at the end of the day.*

*Any moisture in the Carrying Case will cause condensation on the inside of the components which may severely affect accurate operation during the next paving application.*

## Control Box

The Control Box is the operator's interface to System Five™ (Figure 4-1), receiving signals from the sensors, and using these signals to determine if grade or slope corrections are necessary. If the paving requires a change in grade or slope, the Control Box sends a signal to the valve controlling the tow point cylinder on the appropriate side of the paver to raise or lower, thus maintaining correct mat thickness. The operator can control and monitor the slope and thickness of the mat using the buttons and displays located on the front panel of the Control Box.

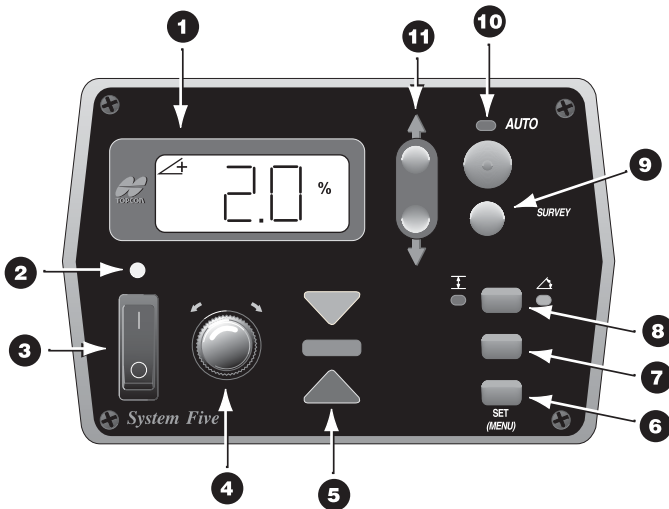

Figure 4-1. 9256 Control Box

- |                                 |                               |
|---------------------------------|-------------------------------|
| 1. LCD                          | 7. Cross Communication Button |
| 2. Light Sensor for LED Display | 8. Slope/Elevation Button     |
| 3. Power Switch                 | 9. Survey Button              |
| 4. Grade Adjustment Knob        | 10. Auto/Manual Button        |
| 5. Grade Adjustment LED         | 11. Jog Button                |
| 6. Set (Menu) Button            |                               |

## LCD

The LCD (Liquid Crystal Display) allows the operator to view text and graphic symbols that represent elevation or slope settings that System Five™ currently maintains for the paver (Figure 4-2).



Figure 4-2. LCD Display

## Light Sensor for LED Display

The light sensor monitors ambient light to adjust the brightness of the LED display for better visibility.

The light sensor is located above the power switch.

## Power Switch

The power switch (Figure 4-3) for the System Five Control Box turns it on and off.

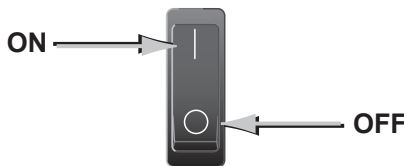

Figure 4-3. Power Switch

## Grade Adjustment Knob

The grade adjustment knob makes measured adjustments to elevation and slope settings, or cycles through menu options.

- Knob adjusts the grade height while in elevation control (Figure 4-4).

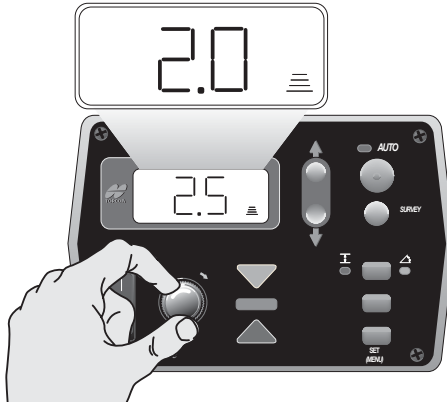

Figure 4-4. Adjusting Grade Height

- Knob adjusts the percentage of slope while in cross slope control (Figure 4-5).

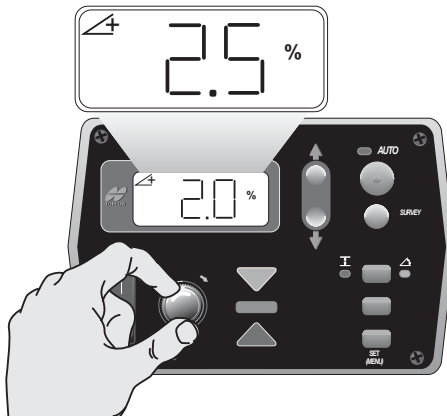

Figure 4-5. Adjusting Cross Slope Control



## Grade Adjustment Direction Arrows

The grade adjustment arrows are located at the upper left and upper right of the grade adjustment knob.

These two arrows (Figure 4-6) light up in red to indicate the direction to turn the knob to reach on-grade.

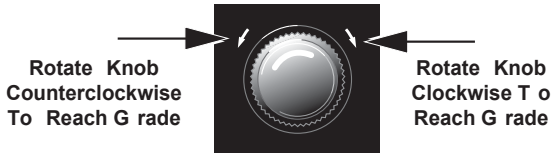

Figure 4-6. Grade Adjustment Direction Arrows

## Grade Adjustment LEDs



The grade adjustment LEDs (Figure 4-7) indicate raise, on-grade, and lower information and corrections.









Figure 4-7. Grade Adjustment LEDs

Table 4-1 describes grade adjustment LED indications.

Table 4-1. LED Indications for Elevation/Slope Control

LED Display	LED	Elevation Description	Slope Description
Slowly blinking, yellow down arrow		Out of range; beyond .2' above grade	Beyond 2% above grade
Solid yellow down arrow		Above grade; between .05' and .2'	Above grade, between 1% and 2%
Blinking yellow down arrow		Above grade; between .02' and .05'	Above grade, between .5% and 1%

**Table 4-1. LED Indications for Elevation/Slope Control (Continued)**

LED Display	LED	Elevation Description	Slope Description
Blinking yellow down arrow w/ green bar		Within .02' of grade	Within .5% of grade
Blinking green bar		On grade	On grade
Blinking red up arrow w/ green bar		Within .02' of grade	Within .5% of grade
Blinking red up arrow		Below grade; between .02' and .05'	Below grade, between .5% and 1%
Solid red up arrow		Below grade; between .05' and .2'	Below grade, between 1% and 2%
Slowly blinking red up arrow		Out of range; beyond .2' below grade	Beyond 2% below grade

### Function Indicator LEDs

The function indicator LEDs (Figure 4-8 on page 4-7) are located below the jog button and next to the slope/elevation, cross communication, and set/menu buttons:

- CON – indicates the box is in Control Mode.
- SUR – indicates the box is in Survey Mode.
- ELEV – indicates the LCD displays the current elevation.
- AVG – indicates the LCD displays the calculated average elevation.

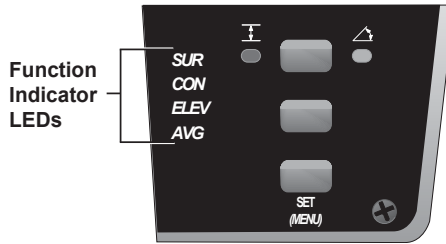

Figure 4-8. Function Indicator LEDs

## Set/Menu Button

The Set/Menu button (Figure 4-9) has two functions:

- Set Mode – used to change the reference number viewed on the display to a desired value.
- Menu Mode – used to access the performance menu.

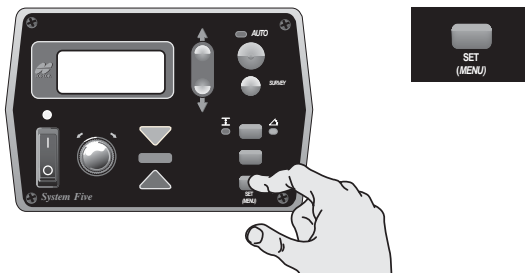

Figure 4-9. Set/Menu Button

## Using the Set Mode

The Set mode is used to change the reference number viewed on the display to a desired value. The reference number is used to set the elevation or slope display number.

1. Press and hold the Set/Menu button.
2. Dial in the desired value using the Grade Adjustment Knob. Both the grade correction indicator lights and the double arrows light up.

3. Release the Set/Menu button and the value will be saved.

**NOTICE** NOTICE

*Using Set only changes the reference number viewed on the display, leaving the existing cutting depth unchanged.*

**Using the Menu Mode**

The Menu mode assigns menu mode functions, allowing you to set valve offsets, units of measurements, an alarm, deadband, and other useful functions.

See “Performance Menu Settings” on page 4-16 for information on using the menu settings.

**Cross Communication Button**

If enabled, the Cross Communication button (Figure 4-10) allows you to remotely control a second Control Box.

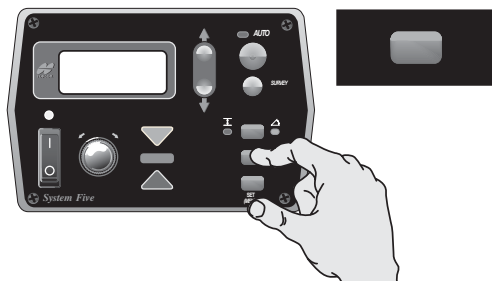

**Figure 4-10. Cross Communication Button**

During cross communication, the Control Box that initiates the communication (primary) displays and controls the settings of the second Control Box.

1. Press and hold the Cross Communication button (Figure 4-11).

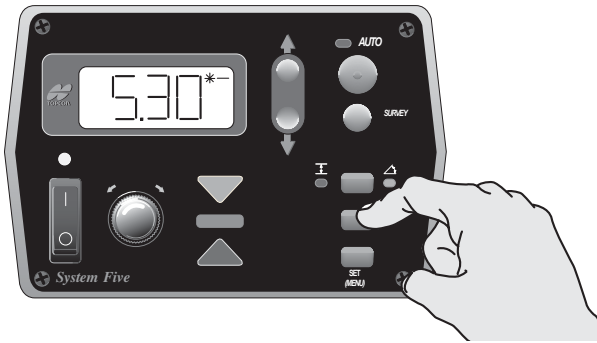

**Figure 4-11. Initiate Cross Communication**

- The left arrow illuminates, indicating cross communication has started (Figure 4-12).

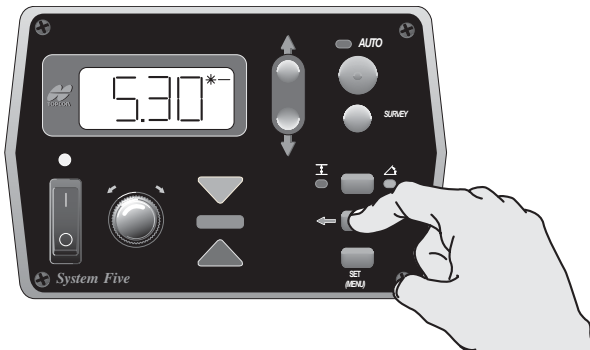

**Figure 4-12. Cross Communication Started**

- The right arrow illuminates once cross communication with the second Control Box has been established. The display now shows the settings of the second box (Figure 4-13 on page 4-10). The cross communication arrows on the second Control Box flash during cross communication.

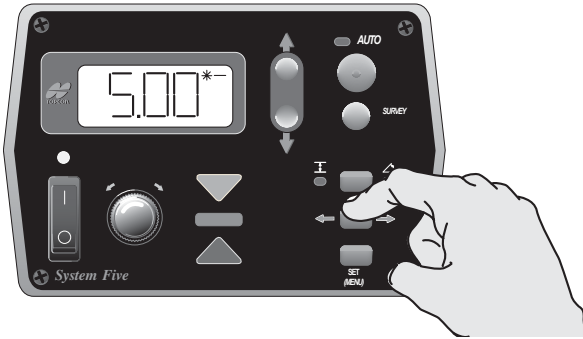

**Figure 4-13. Cross Communication Established – Second Control Box Settings**

2. Hold the cross communication button and view or make changes to the settings in the second box (Figure 4-14).

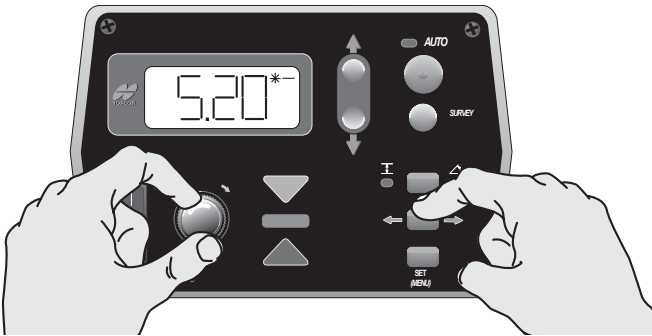

**Figure 4-14. Remotely Change Second Control Box Settings**

3. When finished, or to apply new settings to the second box, release the cross communication button.

## Slope/Elevation Button

The elevation/slope button (Figure 4-15) is used to set the System Five™ for slope or elevation control

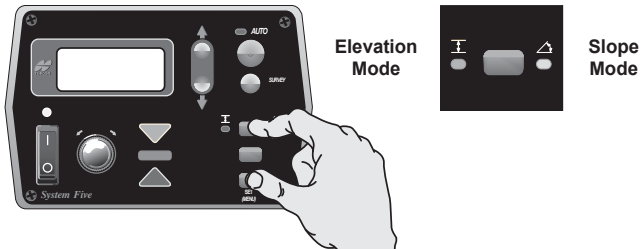

Figure 4-15. Slope/Elevation Button

### Slope Mode

If the Control Box is connected to a slope sensor, the desired cross slope can be dialed in for automatic control.

1. Press the Slope/Elevation button: the yellow LED next to the Cross Slope Symbol illuminates.
2. Turn the Adjustment Knob to get the desired slope.

### Elevation Mode

Press the Slope/Elevation button: the green LED next to the Elevation Symbol illuminates.

## Survey/Indicate Button

Use the survey/indicate (Figure 4-16) button to lock on-grade or continuously monitor the grade or slope setting on the LCD.

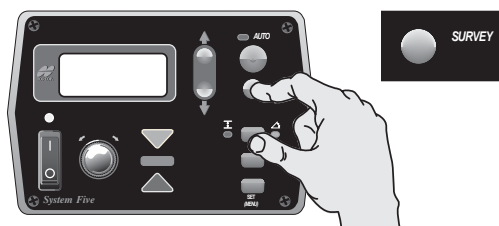

Figure 4-16. Survey/Indicate Button

### Using the Survey Function

Survey sets the sensor to on-grade.

Hold the Survey/Indicate button for one second until the Control Box beeps and the on-grade light illuminates.

### Using the Indicate Function

The grade or slope setting continuously displays on the LCD during indicate mode.

**NOTICE** *NOTICE*

*Indicate puts the System Five in Manual Mode.*

Press and hold the Survey/Indicate button for three seconds, until the Control Box emits a second beep.

“IND” briefly displays on the LCD, then the grade or slope setting. The Grade Adjustment LEDs remain dark.

To exit Indicate Mode, push either the Survey/Indicate button or the Auto button.



## Auto/Manual Button

The auto/manual button (Figure 4-17) has three functions:

- In Automatic Mode, the tow point cylinders are automatically adjusted as needed.
- In Manual Mode, displays grade corrections without adjusting the tow point cylinders.
- Makes selections in the Performance Menu.

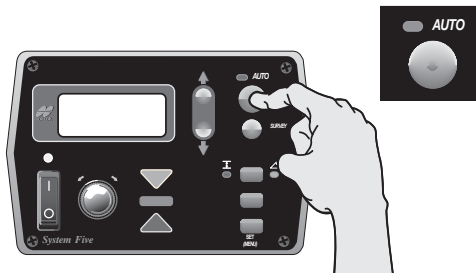

Figure 4-17. Auto/Manual Button

### Using Automatic Mode

In automatic mode, the tow point cylinders are automatically adjusted up or down to maintain proper grade.

To enter auto mode, press the red button. The red LED lights up showing that the Control Box is in auto mode.

### Using Manual Mode

In manual mode, the LED displays grade corrections without adjusting the tow point cylinders. In this mode, the operator manually adjusts the tow point cylinders to reach on-grade.

To enter manual mode, press in the red button. The red LED will go dark (unlit), showing that the Control Box is in manual mode.

## Making Selections in the Performance Menu

When using the Performance Menu, the Auto/Manual button selects settings and functions for the System Five Control Box. See “Performance Menu Settings” on page 4-16 for information on the different menus available.

## Jog Button

The jog button (Figure 4-18) manually moves the tow point up or down, and is always active when the Control Box is turned on.

- To raise the tow arm cylinder, push switch up.
- To lower the tow arm cylinder, push switch down.

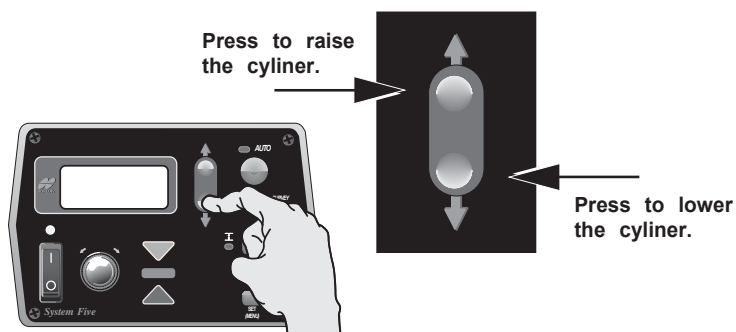

Figure 4-18. Jog Button

## Other Control Box Components

Other Control Box components include the following (Figure 4-19 on page 4-15):

1. Mounting Knob – secures the Control Box to its mounting bracket. The bracket has a jaw that matches up with the jaw located on the side of the Box.
2. Serial Number Plate – contains Systems Five part and serial numbers.

3. Audible Beeper – When the power is turned on, or calibration selections are made, the beeper will sound. The beeper may be turned Off or On for certain functions by using the Beeper Alarm Mode (see the Accessing System Five™ Performance Settings section).

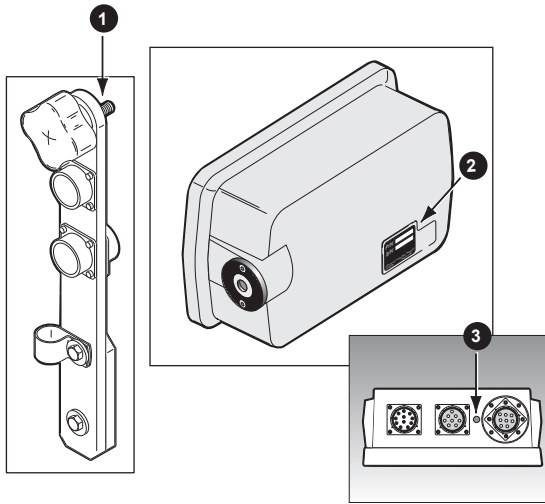

**Figure 4-19. Other Control Box Components**

## Performance Menu Settings

The System Five™ Control Box Performance Menu settings are a series of features that allow System Five to be modified for operator or performance enhancement. The Control Box automatically stores all operating information when it is turned off.







If power is interrupted to the Control Box within two seconds after making an adjustment, the new setting will not have had time to be stored and the settings will revert to previous (or original) settings.

**NOTICE** NOTICE

*For some machine configurations, some menu selections are inaccessible.*

Table 4-2 lists the Control Box menus and their settings.

**Table 4-2. Performance Menu Settings**

Menu	LED Symbol	Range	Factory Setting
Gain (Elevation)		1 – 200	25
Gain (Slope)		1 – 200	25
Valve Offset		1 – 999	135
Averaging		1 – 100	50
Elevation Deadband		1 – 30 mm	3 mm
Slope Deadband		.025% – .75%	0.075%

**Table 4-2. Performance Menu Settings (Continued)**

Menu	LED Symbol	Range	Factory Setting
Beeper	BEP	on/off	off
Unit	UNIT	in, ft, cm	in
Test	TEST	open, short, pass	no setting

Factory settings are preset values that will run most pavers. If your machine does not perform properly within those preset values, adjust the setting accordingly until you have satisfactory machine performance.

Follow these steps to access the Performance Menu.

1. Turn power off. While holding down the Set/Menu button turn the box back on (Figure 4-20). The Auto LED light and Grade Adjustment Direction arrows will flash.

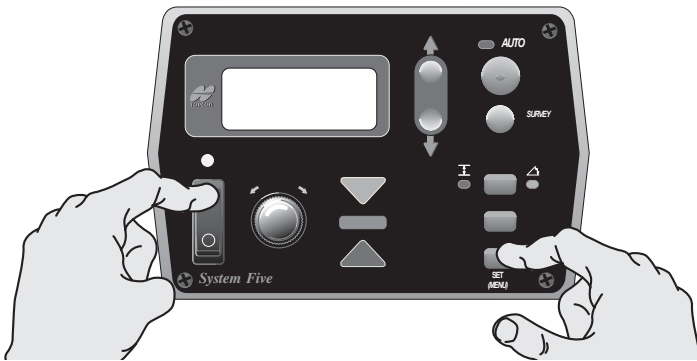
**Figure 4-20. Accessing the Performance Menu**

2. Rotate the Grade Adjustment Knob to scroll through the menu selections located on the LCD (Figure 4-21).

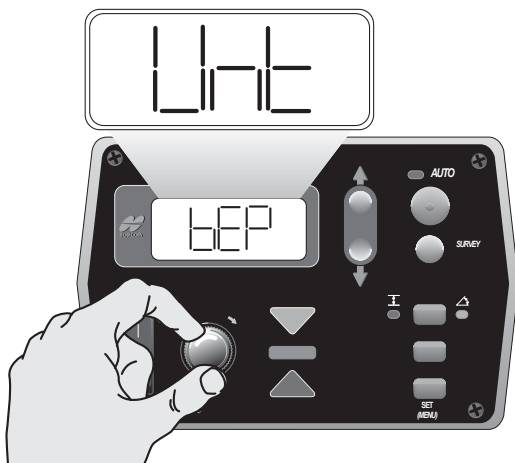

Figure 4-21. Scrolling through the Performance Menu

3. Press the Auto button to select a menu item (Figure 4-22).

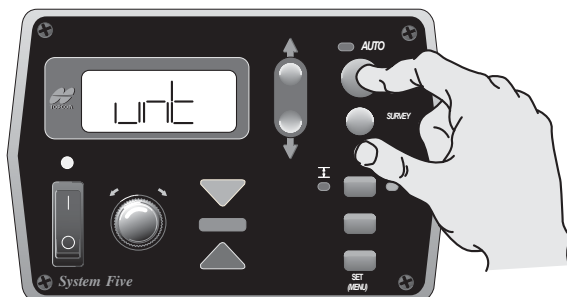
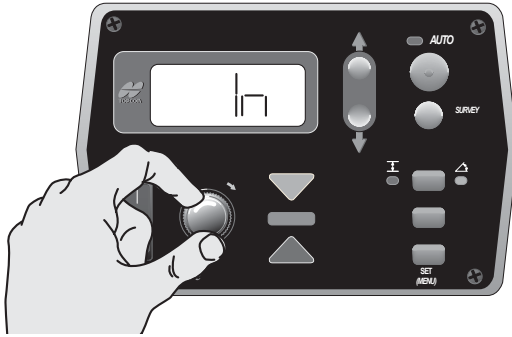

Figure 4-22. Selecting Performance Menu Items

- Turn the Grade Adjustment Knob to view the options available for the Menu selection (Figure 4-23).



**Figure 4-23. View Menu Options**

- Press the Auto button again to store value (Figure 4-24).

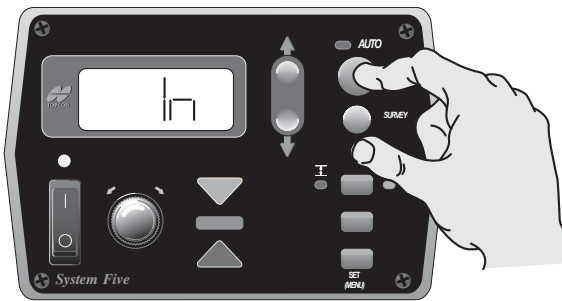

**Figure 4-24. Storing Menu Value**

- To access other Menu settings, turn the Grade Adjustment Knob. To exit the Performance Menu, press the Set/Menu button.

See the following sections for greater detail on each menu item.

## Gain (Elevation)

This setting determines the speed at which System Five allows the tow point cylinders to adjust to a change in elevation. For faster hydraulic response, increase the gain value. For slower hydraulic response, decrease the gain value.

The objective is to set the gain so the screed reacts to the change in grade quickly, but without “overshooting” the new elevation.

- Gain Elevation Value Range: 1-200
- Factory Preset: 25

Before setting the Gain, make sure the machine's hydraulic flow controls valves are adjusted for proper cylinder speed according to the manufacturer's recommendations. Typical cylinder speed is 15-20 seconds for full up or down cylinder travel.

1. From the Performance Menu, press the Auto button to select Gain (Elevation) (Figure 4-25).

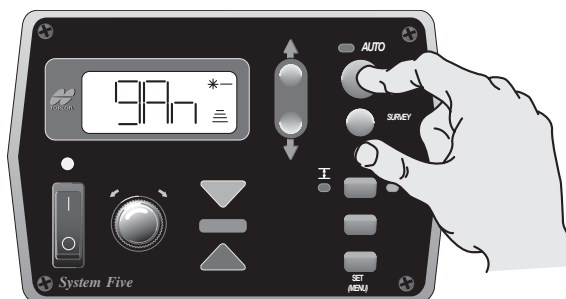

**Figure 4-25. Selecting Gain Elevation**

2. Turn the Grade Adjustment Knob to select the desired value, typically 25 for most paving applications (Figure 4-26 on page 4-21).



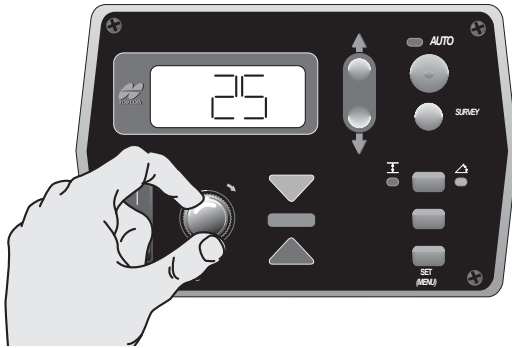

**Figure 4-26. Selecting Gain Menu Option**

3. Press the Auto button again to store value.
4. Rotate the Grade Adjustment Knob to access another item in the Performance Menu, or press the Set/Menu button to exit.

## **Gain (Slope Control)**

This setting determines the speed at which System Five allows the tow point cylinders to adjust to a change in slope. For faster hydraulic response, increase the gain value. For slower hydraulic response, decrease the gain value.

The objective is to set the gain so the screed reacts to the change in grade quickly but without “overshooting” on-grade. Slope gain should not be set at a higher value than the elevation gain on the other side of the paver.

- Gain Elevation Value Range: 1-200
- Factory Preset: 25

Before setting the Gain, ensure the machine's hydraulic flow control valves are adjusted for proper cylinder speed according to the manufacturer's recommendations. Typical cylinder speed is 15-20 seconds for full up or down cylinder travel.

1. From the Performance menu, press the Auto button to select Gain (Slope Control) (Figure 4-27).

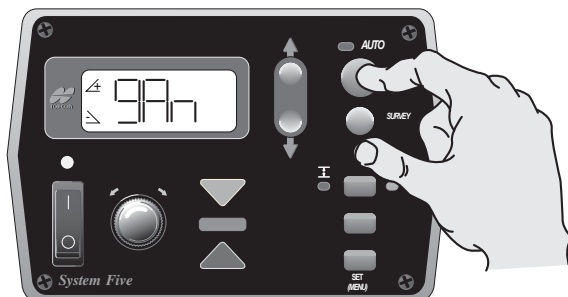

**Figure 4-27. Select Gain (Slope Control)**

2. Turn the Grade Adjustment Knob to select the desired value, typically 20% to 25% (Figure 4-28).

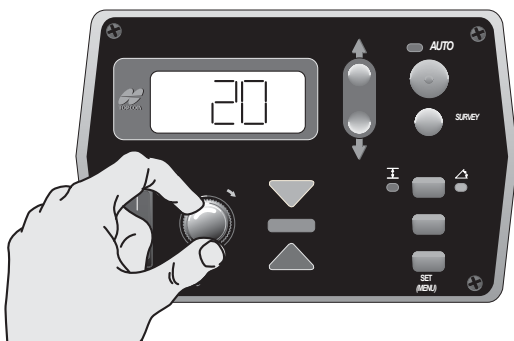

**Figure 4-28. Selecting the Gain Value**

3. Press the Auto button again to store value.
4. Rotate the Grade Adjustment Knob to access another item in the Performance Menu, or press the Set/Menu button to exit.

**NOTICE** NOTICE

*Do not set slope gain at a higher value than the elevation gain on the other side of the paver. A higher value may cause the slope to be over reactive.*

### Valve Offset

The valve offset is the minimum amount of electrical signals sent to the valve which causes the hydraulic cylinder to move. If the valve offset is too small, the sensor will not reach on-grade. Likewise, if the valve offset value is too large, the sensor will move too much and overshoot On-Grade.

**NOTICE** NOTICE

*Valve offsets should be the first performance menu function completed.*

Valve offsets should be set before adjusting elevation and slope gains, and averaging. The paver should be run until the hydraulic oil is at normal operating temperature before the value offset function is performed. Once they are set, valve offsets should not need to be adjusted unless the Control Box has been moved to a new paver, or the hydraulic performance has changed.

- Valve Offset value range – 1 to 999
- Factory preset – 135

Table 4-3 lists suggested valve offsets for different valve types.

**Table 4-3. Suggested Valve Offsets**

Valve	Offset
Solenoid	135
Proportional	350

1. From the Performance Menu, press the Auto button to select Valve Offset. This will automatically activate the value screen for Raise Offsets. The raise grade correction display arrow illuminates, and the Control Box will begin sending a raise correction signal to the valve (Figure 4-29).

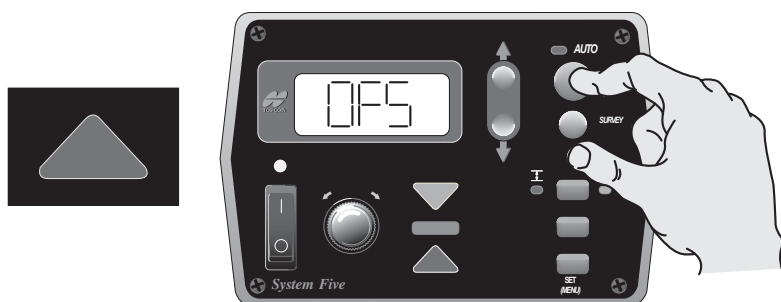

**Figure 4-29. Select Valve Offset**

2. Turn the Grade Adjustment Knob counter clockwise, decreasing the valve offset value until the hydraulic cylinder no longer moves. Then slowly rotate the Grade Adjustment Knob clockwise until the hydraulic cylinder just begins to move up (Figure 4-30).

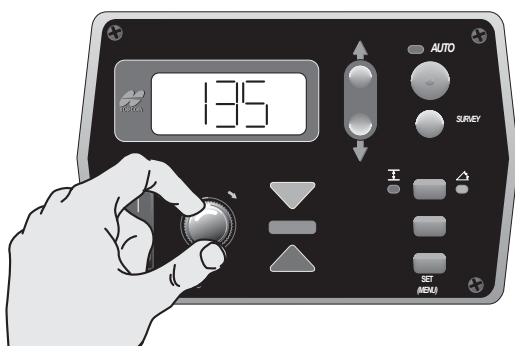

**Figure 4-30. Setting the Raise Valve Offset Value**

3. Press the Auto button to store the Raise Offset Value (Figure 4-31 on page 4-25).

Pressing the Auto button also switches the box to Lower Offset. The Lower Grade Correction Display arrow will illuminate and the Control Box will begin sending a lower correction signal to the value (Figure 4-31).

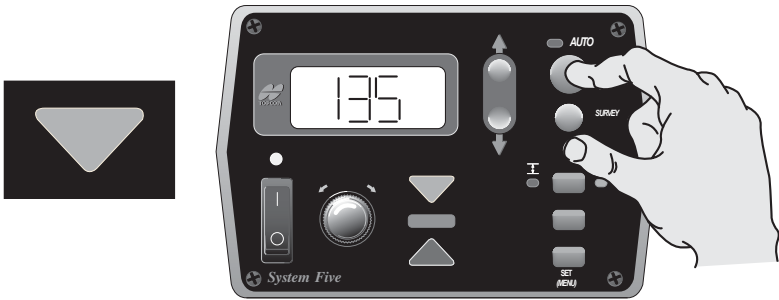

**Figure 4-31. Storing the Raise Offset Value**

4. Turn the Grade Adjustment Knob counter-clockwise, decreasing the valve offset value until the hydraulic cylinder no longer moves. Then slowly rotate the Grade Adjustment Knob clockwise until the hydraulic cylinder just begins to move down (Figure 4-32).

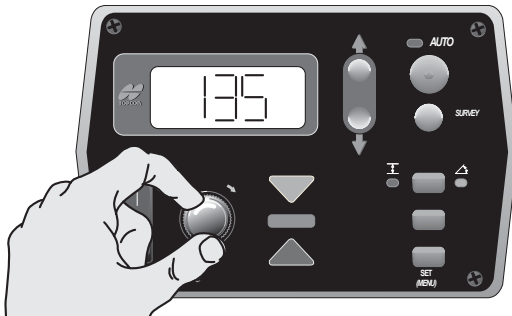

**Figure 4-32. Setting the Lower Valve Offset Value**

5. Press the Auto button to store the lower valve offset value and return to the Performance Menu.
6. Rotate the Grade Adjustment Knob to access another item in the Performance Menu, or press the Set/Menu button to exit.

## Averaging

This setting changes the amount of dampening, or filtering, applied to sonic tracker and laser receiver measurements. It can be thought of as the time period over which a running average of the elevation measurement is calculated. A lower value will average fewer elevation measurements, allowing the system to react more quickly to smaller grade changes. This will make it more susceptible to fluctuations in temperature or small obstructions.

A larger value will average more elevation measurements, preventing the system from reacting to undesirable items close to the reference. This will also make it less susceptible to fluctuations in temperature or small obstructions.

- Averaging value range – 1 to 100
  - Factory preset – 50
1. From the Performance Menu, press the Auto button to select Averaging (Figure 4-33).

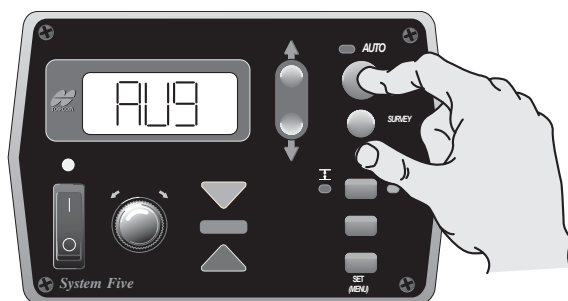

Figure 4-33. Select Averaging

2. Turn the Grade Adjustment Knob to select the desired value (Figure 4-34).

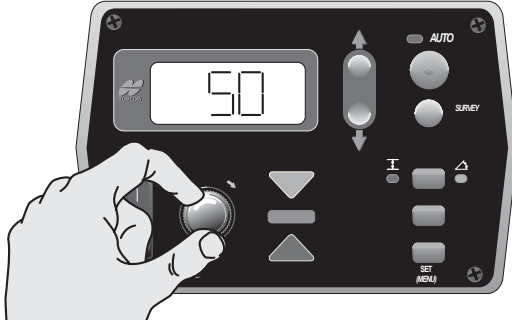

Figure 4-34. Select Value

3. Press the Auto button again to store the value.
4. Rotate the Grade Adjustment Knob to access another item in the Performance Menu, or press the Set/Menu button to exit.

## Deadband Elevation

Deadband is the area of the Working Window that is on-grade. While the reference is within that area, the paver's valves are idle (closed). Therefore the wider the Deadband (on-grade area), the more a reference can move up or down without a correction being initiated. Once the signal from the reference is out of the deadband, System Five will drive the hydraulics to place the reference back in the CENTER of the deadband.

- Deadband Elevation value range – 1 to 30mm
- Factory preset – 3mm (01' or 1/8")

### **NOTICE** NOTICE

Select the amount of Deadband carefully selected. Too small of a Deadband will cause the tow point cylinder to constantly hunt up and

*down while the sensor tries to find On-Grade. Too large of a deadband will not allow the sensor to send grade corrections to the valves, causing unwanted variations in the mat thickness.*

1. From the Performance Menu, press the Auto button to select Elevation Deadband (Figure 4-35).

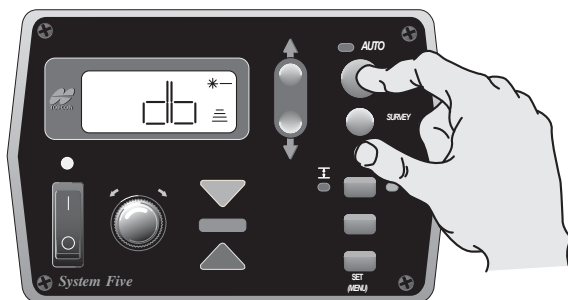

**Figure 4-35. Select Elevation Deadband**

2. Turn the Grade Adjustment Knob to select the desired value, typically 3mm (0.01') (Figure 4-36).

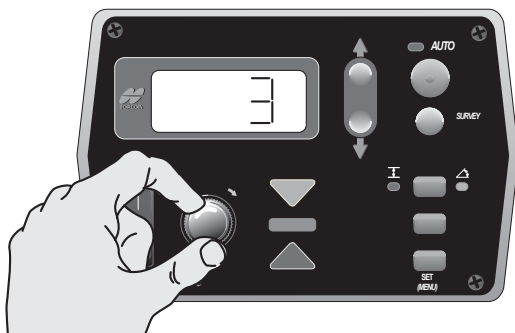

**Figure 4-36. Select Value**

3. Press the Auto button again to store the value.
4. Rotate the Grade Adjustment Knob to access another item in the Performance Menu or press the Set/Menu button to exit.



## Deadband Slope

Deadband is the area of the Working Window that is on-grade. While the reference is within that area, the paver's valves are idle (closed). Therefore the wider the Deadband (on-grade area), the more a reference can move up or down without a correction being initiated. Once the signal from the reference is out of the deadband, System Five™ will drive the hydraulics to place the reference back in the CENTER of the deadband.

When the Deadband is changed, it adds or takes away from the fine correction region (1% above or below on-grade) of the slope sensor; it does not add this distance to the overall working range.

- Deadband Slope value range – 025 to 750%
- Factory preset – 075%



### NOTICE

*Select the amount of Deadband carefully. Too small of a Deadband will cause the tow point cylinder to constantly hunt up and down while the sensor tries to find on-grade. Too large of a deadband will not allow the sensor to send grade corrections to the values, causing unwanted variations in the mat thickness.*

1. From the Performance Menu, press the Auto button to select Slope Deadband (Figure 4-37).

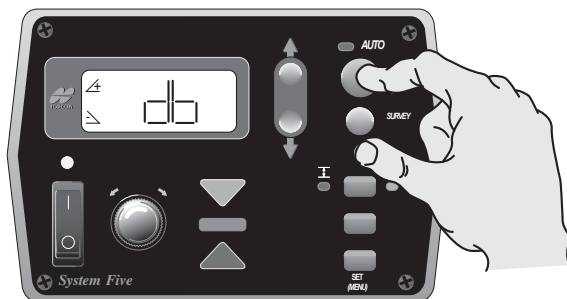

**Figure 4-37. Selecting Slope Deadband**

2. Turn the Grade Adjustment Knob to select the desired value, typically 075 (Figure 4-38).

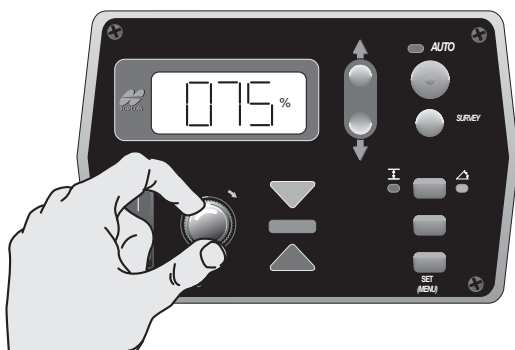

**Figure 4-38. Select Value**

3. Press the Auto button again to store the value.
4. Rotate the Grade Adjustment Knob to access another item in the Performance Menu, or press the Set/Menu button to exit.

## Beeper Alarm

When in Automatic Mode and the Sonic Tracker receives a reference signal outside of the Working Window (more than 2.0" from grade), a single audible beep will be heard.

1. From the Performance Menu, press the Auto button to select Beeper (Figure 4-39).

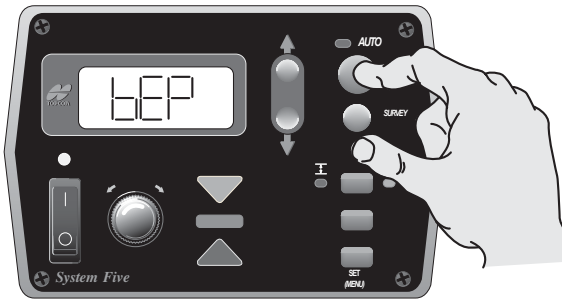

Figure 4-39. Select Beeper

2. Turn the Grade Adjustment Knob to turn the beeper ON or OFF (Figure 4-40).

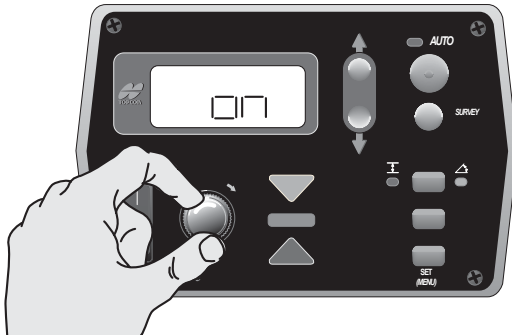

Figure 4-40. Turning Beeper On

3. Press the Auto button again to store the choice.
4. Rotate the Grade Adjustment Knob to access another item in the Performance Menu, or press the Set/Menu button to exit.

## Unit

The Unit menu item sets the display to read in feet, inches, or centimeters.

**NOTICE** NOTICE

*If the Unit value is changed, the working window of the Sonic Tracker will have to be reset to grade.*

1. From the Performance Menu, press the Auto button to select Units (Figure 4-41).

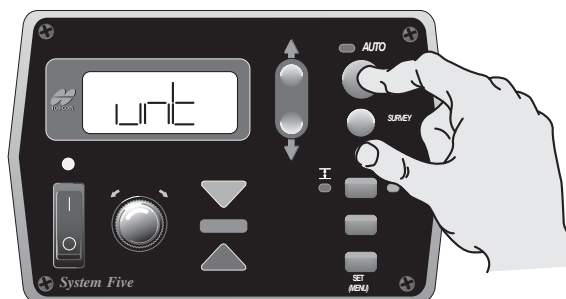

**Figure 4-41. Select Units**

2. Rotate the Grade Adjustment Knob to select a unit for measuring (feet, inches, or centimeters) (Figure 4-42 on page 4-33).

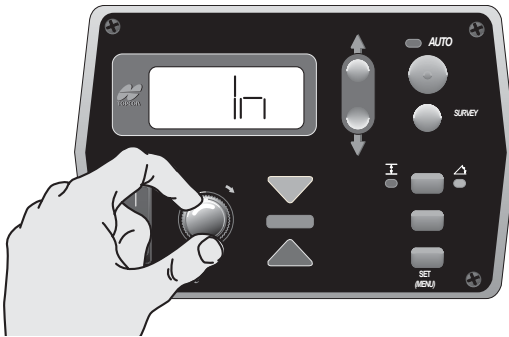

**Figure 4-42. Select Measuring Unit**

Table 4-4 displays and describes the three options available for the Units menu.

**Table 4-4. Unit Measurement Descriptions**

Measurement Display	Description	Numerical Display Example	Description
	Inches		2 1/2 inches
	Feet		25 hundredths of a foot
	Centimeters		2 1/2 cm (25mm)

3. Press the Auto button again to store the value.
4. Rotate the Grade Adjustment Knob to access another item in the Performance Menu or press the Set/Menu button to exit.

## Test

This menu item tests the valves for shorts and disconnected valves. It test the Raise Valve first and then the Lower Valve.

1. From the Performance Menu, press the Auto button to select Test Mode (Figure 4-43).

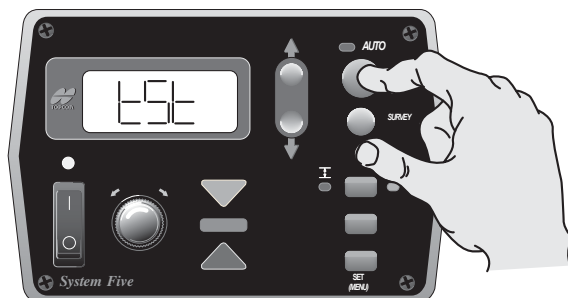

**Figure 4-43. Select Test Mode**

The raise valves test first.



- The display shows “Pass” if the raise valves test OK.
- If there is a problem, the display will read “Open” or “Short”.

Table 4-5 on page 4-35 summarizes the Test solutions.

2. Press the Auto button to test the lower valves.
  - The display shows “Pass” if the lower valves test OK.
  - If there is a problem, the display will read “Open” or “Short”.

Table 4-5 on page 4-35 summarizes the Test solutions.

**Table 4-5. Test Solutions**

Test Display	Description
	Good Valve
	Valve NOT connected (OR Danfoss valve output being used) (OR connected to existing proportional control valves)
	Valve wires have shorted electronically

3. Press the Auto button once more to return to the Menu selections.
4. Rotate the Grade Adjustment knob to access another item in the performance menu or press the Set/Menu button to exit.





# **G**etting Ready to **Pave**

This chapter is designed to get the paving crew started using System Five™. The job application and the desired results will determine what type of non-contacting controls should be used; i.e. sonic, slope, laser and SAS.

- For Sonic Tracker II and SmoothTrac SAS setup, first attach the Sonic Trackers, then setup the Control Box.
- For Slope Sensor setup, first attach and power up the Control Box, then check the sensor's calibration to ensure correct grade.
- For Laser Tracker setup, first setup the laser transmitter, attach the Laser Tracker to the machine, then setup the Control Box.

The components should be mounted on the paver and then the paver itself must be properly set up.

## Control Box Setup

Use the following steps to install the Control Box (Figure 5-5).

1. Attach the Control Box to its bracket.
2. Connect the cables to the Control Box.
3. Turn on the Control Box.

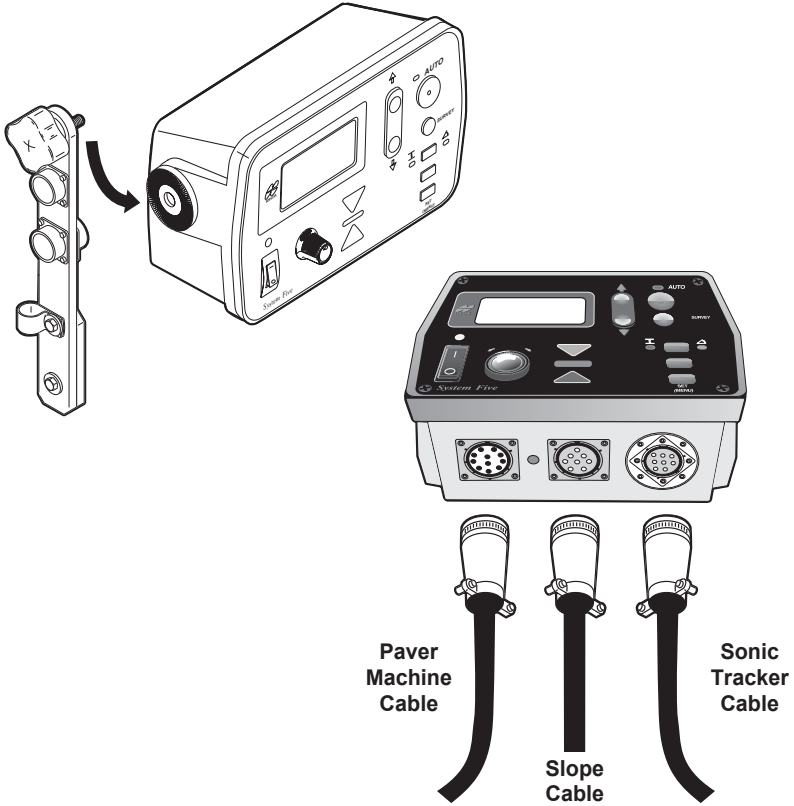

Figure 5-1. Attach Control Box and Connect Cables

**NOTICE** NOTICE

*Due to different types of machine configuration, cable connections may vary.*

## Screed Setup

To start paving with System Five, set up the paver just as you would under manual control.

1. Place the screed on blocks or lath set for the desired paving thickness (Figure 5-2); make sure to account for material compaction.

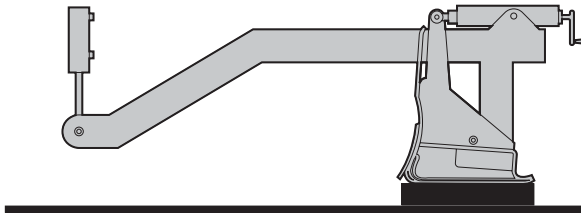
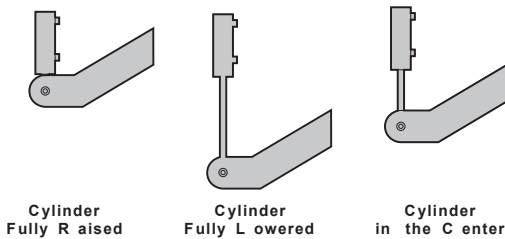

Figure 5-2. Place Screed on Blocks

2. Center the tow point cylinders to maximize travel in raise or lower directions (Figure 5-3): use the jog switch on the Control Box or the switch provided with the Paver.



Cylinder  
Fully Raised

Cylinder  
Fully Lowered

Cylinder  
in the Center

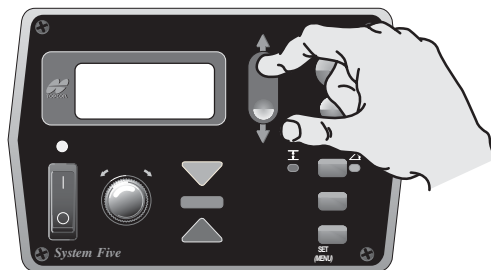

Figure 5-3. Center the Tow Point Cylinders

- Using the manual thickness adjustment cranks or hand cranks on the paver, null the screed and set the proper angle of attack (Figure 5-4).

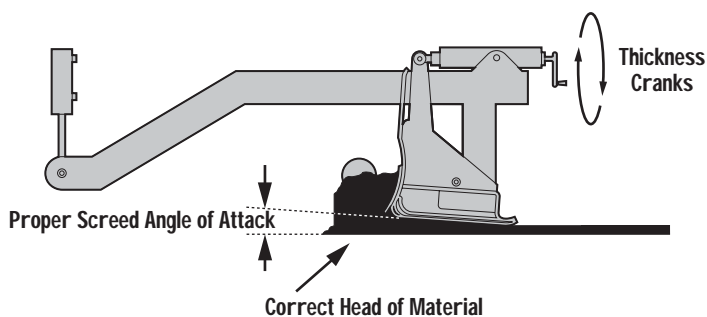

Figure 5-4. Manually Adjust Thickness of Mat

- Next, turn on the auger feeder controls to place the asphalt in front of the screed.

## Sonic Tracker Setup

The following steps describe installing and positioning the Sonic Tracker II on the Paver (Figure 5-5 on page 5-5).

- Connect the coil cord to the Tracker.
- Bolt the Tracker to the bracket, and visually check to get the Sonic Tracker plumb.
- Make one wrap of the coil cord around the L-Bar. This will act as a strain relief for the connector on the Tracker.

Be sure the coil cord snap hook is in place and secure.

- If needed, snap the temperature bail into place
- Place the Sonic Tracker over the reference: raise or lower the Tracker bracket to position it at a proper height above the grade reference.
- Push the Survey button on the Control Box to lock trackers on-grade.

7. Push and hold the Set button while dialing in mat depth.
8. Put the Control Box in Auto and begin paving.

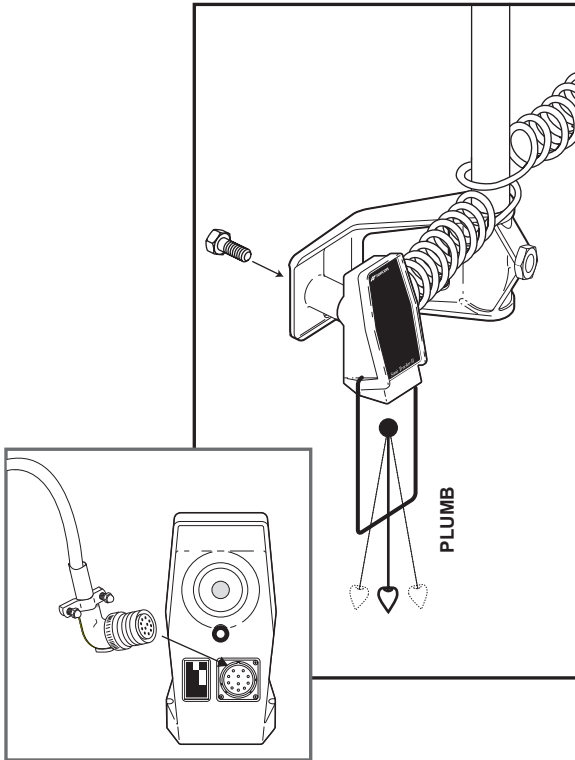

**Figure 5-5. Sonic Tracker Setup**

## SAS Setup

Once the SAS has been installed, the System Five Control Box will automatically configure for SAS when powered on. The box will check to see how many trackers are connected and average over that amount. Getting the Control Box ready to pave is the same as with one tracker.

1. Connect each tracker as described in “Sonic Tracker Setup” on page 5-4, but using the SAS coil cord.
2. Place the SAS trackers over the reference: raise or lower the trackers bracket to position it at a proper height above the grade reference.
3. Push and hold the Set button while dialing in mat depth.
4. Put the Control Box in Auto and begin paving.



### NOTICE

*It is not necessary to start paving in manual as is traditionally done when using a mechanical ski. If the setup procedures are followed correctly, paving with the SAS can and should start in automatic.*

The SAS system has been designed to discontinue operating when one of the Trackers fails. When a failure occurs, the control box will flash “ERR” followed by a number from 1 to 4. The number represents the Tracker which failed, making troubleshooting easy and fast.

To reset the control box once a new tracker has been installed, or if the tracker has been removed and only three trackers will be used, turn the power off then on. The control box will reconfigure to the number of trackers. Changing the number of trackers may change the average distance. Re-survey the Control Box to lock SAS on-grade.

Once one of the Trackers has been eliminated from the averaging, the balance point of the beam will have changed. If the faulty Tracker is not replaced the beam will need to be repositioned to adjust for the new balance point. It is strongly recommended, if the first or last Tracker fails, to replace it with one of the Trackers from the middle of the beam. This will insure that the balance point is not outside of the 1/3 to 2/3 rule.

**NOTICE** NOTICE

*A number reading of "1" could mean the first or last Tracker has failed depending on which side of the paver the beam has been mounted. The SAS cable is labeled with numbers at each connector for easy identification.*

## Control Box Setup for Elevation

Once the Sonic Tracker has been positioned over the reference, the Control Box can now set the tracker on-grade.

1. With the power on, press and hold the Survey button for one second until the box beeps and the green on-grade bar lights up (Figure 5-6).

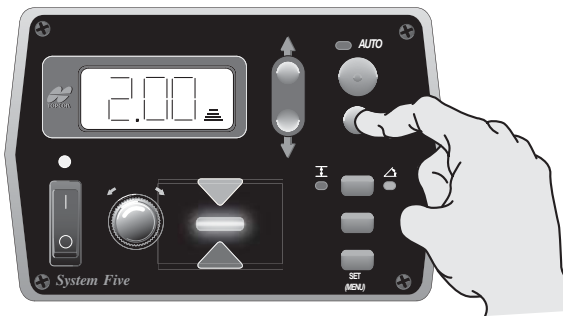

Figure 5-6. Setting the Tracker On-grade

2. To make the display read the same value as the depth of mat to be laid, press and hold the Set button while turning the grade adjustment knob to change the display to the height of the blocks under the screed (Figure 5-7).
3. Release the Set button to save the value.

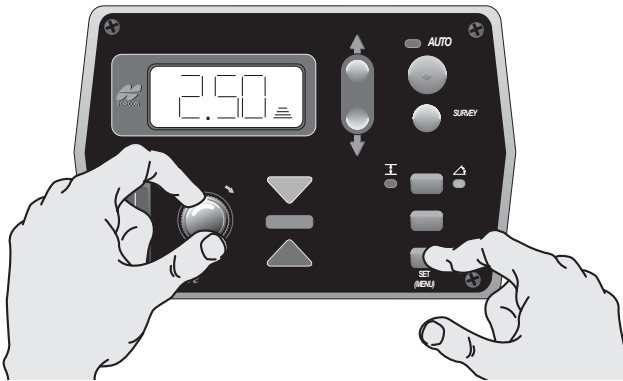

Figure 5-7. Saving Elevation Value

Using Set will not change the existing mat thickness, it only changes the reference number viewed on the display.

4. Press the Auto/manual button to put the Control Box into automatic mode (Figure 5-8). The Auto LED will light up.
5. Begin paving.

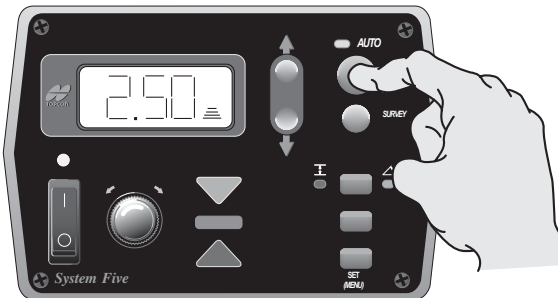

Figure 5-8. Selecting Automatic Mode



After you begin paving, check the mat depth to ensure the desired thickness is being laid (Figure 5-9). The blocks initially placed under the screed may cause the mat to be too thick or too thin. Check the mat several times to get an average before making any corrections.



**Figure 5-9. Checking Pad Thickness**

For example, if a 2.50 inch mat is required, but a 3.0 inch mat is being laid, then an adjustment is necessary. You must first get the box to display the same number as the mat depth.

To change the mat depth being laid,

1. Press the Auto/manual button to put the Control Box and Paver into manual mode. The Auto LED goes dark.
2. Press and hold the Set button while turning the Grade Adjustment Knob to read 3.0 inches (Figure 5-10 on page 5-10). Release the Set button to apply the setting.

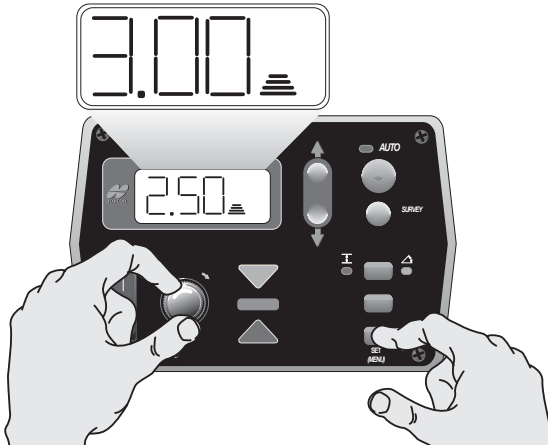

Figure 5-10. Adjusting Grade

3. Press the Auto/manual button return the system to auto mode.
4. With the paver moving and in auto, slowly dial the display from 3 inches down to 2.5 inches (Figure 5-11).

How fast you turn the knob depends on how smooth you want the transition to take place. Highways require gradual changes, parking lots require quick changes. The display should now read the depth of the mat being laid.

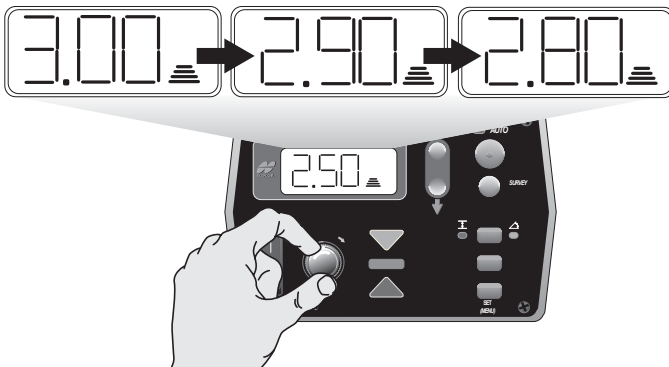

Figure 5-11. Slowly Adjusting Grade

## Control Box Setup for Cross Slope

The slope sensor should already be mounted on the transverse beam of the paver. The sensor can talk to both control boxes, but only one at a time. The sensor communicates to the Control Box through the cable.

To pave using cross slope you must first calibrate the slope sensor, to the screed.

1. Find a smooth area where the screed can rest evenly across its entire surface. Using a laser, a Smart Level, or a slope board, that itself has been calibrated, check the cross slope and direction of fall of the ground (Figure 5-12).

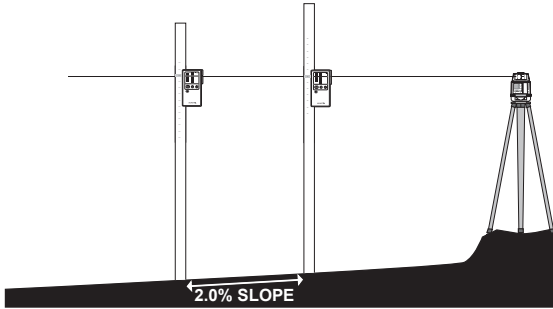

Figure 5-12. Checking Slope

2. Place the screed on the ground and null it out.

3. With the Control Box on, push the Slope Mode button. The yellow LED next to the cross slope symbol will illuminate (Figure 5-13).

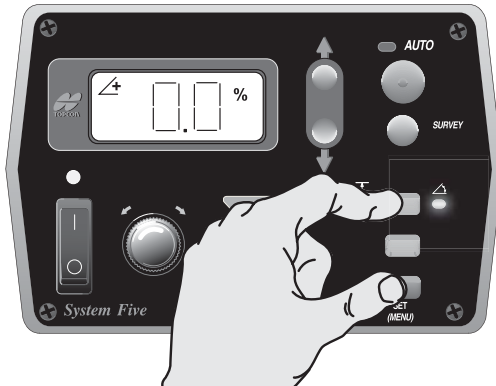

Figure 5-13. Accessing Cross Slope Mode

4. To find out the slope and direction of fall the slope sensor thinks the screed is resting on, push the Survey button for one second to lock sensor on-grade (Figure 5-14).
  - If the box is displaying an on-grade bar and a slope value that is identical to the laser or Smart Level then you can begin paving. Make sure to push the Auto/manual button to put the Control Box into automatic control.

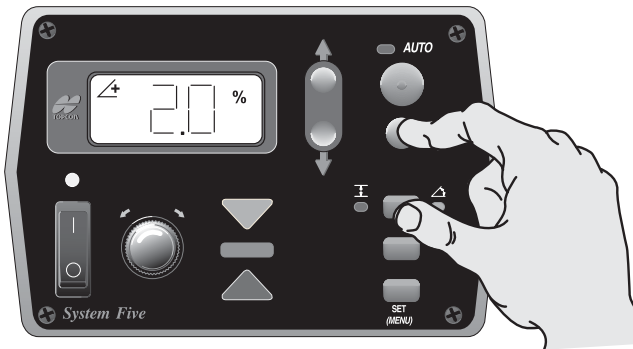
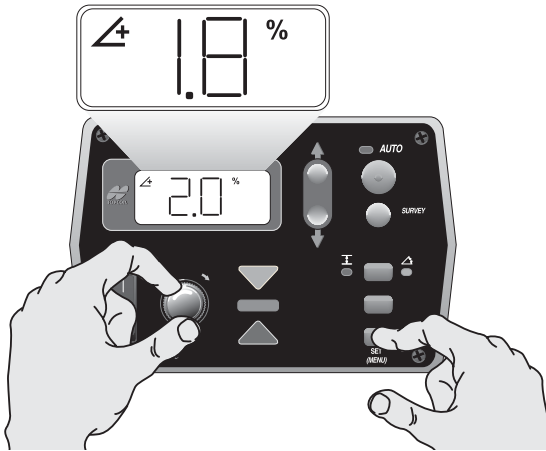

Figure 5-14. Identifying Slope

- If the slope displayed in the box does not match the surface, then the sensor must be calibrated.

Press and hold the Set button while turning the Grade Adjustment Knob to change the display to match the slope of surface (Figure 5-15). Release the Set button to save the value.



**Figure 5-15. Calibrating Slope Sensor**

**NOTICE** NOTICE

*Using Set will not change the slope, it only changes the slope value viewed on the display.*

5. Press the Auto/manual button to enter automatic mode and begin paving. The Auto LED will light up.

Once the slope sensor is calibrated and you are ready to begin paving, you may find the existing surface does not have the same slope as the finish design.

In order to produce a smooth transition, begin paving at the existing slope and slowly turn the grade adjustment knob to change the cross slope to the correct percentage.

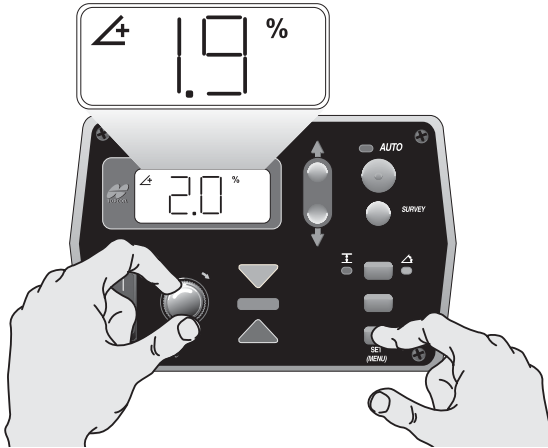

**Figure 5-16. Producing a Smooth Slope Transition**

If a smooth transition is not required, then dial in the desired slope and begin paving.

# T Tracker and SAS Placement

Whether setting up a standard Sonic Tracker II system or a Smoothtrac SAS, consider the following for each Tracker:

- The Tracker has a total working range of 14 inches to 55 inches—41 inches of adjustment—allowing the Tracker to be set over a stringline on one pass, then match grade on the next pass without moving the tracker.

Therefore, the job application determines the position of the Tracker. For example, when using a stringline reference, keep the Tracker about two feet above the string, giving the operator about six inches of lateral movement to keep the Tracker over the string. When tracking a curb, lower the Tracker to keep it over the lip of the curb, preventing the Tracker from “seeing” the top, or face, of the curb.

- When setting up the Tracker over a grade reference, consider the size of the Sonic Cone, or the “footprint”. For example, at about two feet from the Tracker, the footprint, or cone, will be about six inches.
- The Tracker compensates for temperature changes only within the bail range. Placing the Tracker too far from the reference may cause inaccurate temperature compensation.
- Temperature and atmospheric conditions affect the speed of sound. In paving applications, the air temperature can change rapidly and dramatically. A temperature bail attached to the tracker compensates for these variations. If the jobsite has high

winds and/or large temperature fluctuations, lower the Tracker closer to the reference.

The following sections detail the positioning tracker in relation to the grade reference, as well as on the machine.

## Sonic Tracker Positioning in Relation to Reference

Raise or lower the tracker bracket to position the tracker at the proper height above the grade reference (Figure 6-1). The tracker has a total working range of 14 to 55 inches. For paving applications the recommended working height would be from 14 to 24 inches. At 55 inches the sonic footprint would be very large and the tracker may pick up an undesired reference. The tracker also compensates for temperature changes only within the bail range. Placing the tracker too far from the reference may not allow for accurate temperature compensation.

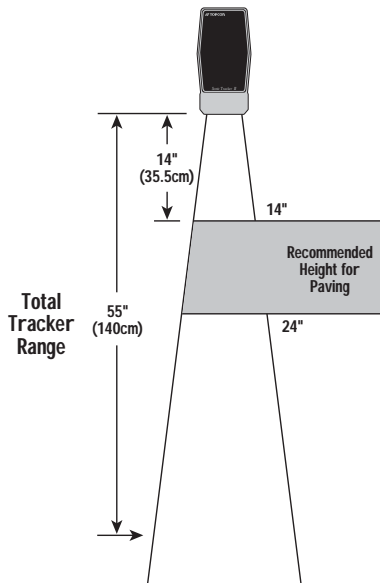

Figure 6-1. Recommended Tracker Placement



## L-bar Positioning

Position the L-Bar horizontally so the tracker will be over the reference. For example, when tracking a curb and gutter, place the screed or extension flush with the edge of gutter and slide the L-Bar so the Tracker is over the lip of the gutter (Figure 6-2).

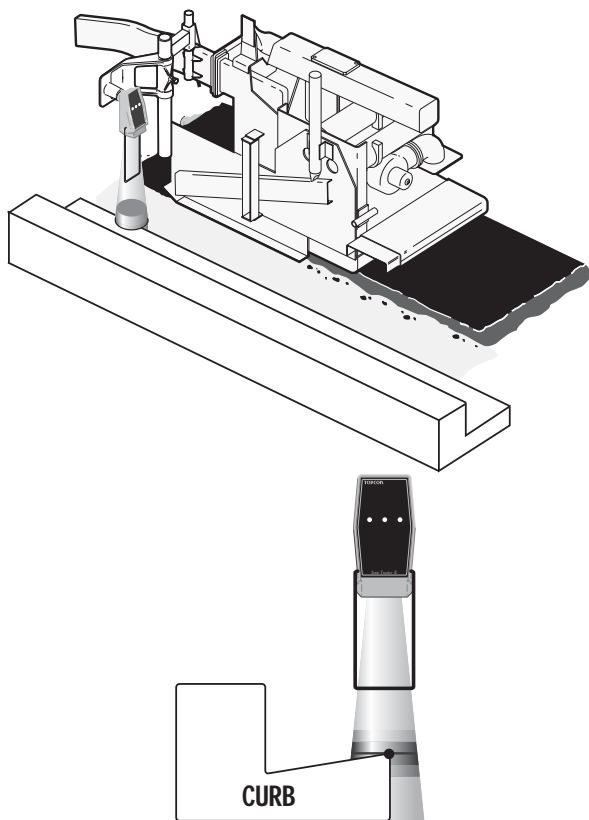

Figure 6-2. Positioning the L-Bar with Tracker

The L-Bar can also be mounted to a bracket on the screed extension (Figure 6-3). This would work well in applications where the reference will not be a constant width and requires the extension to be moved in and out. Mounting to the extension will make it easier to keep the tracker over the reference.

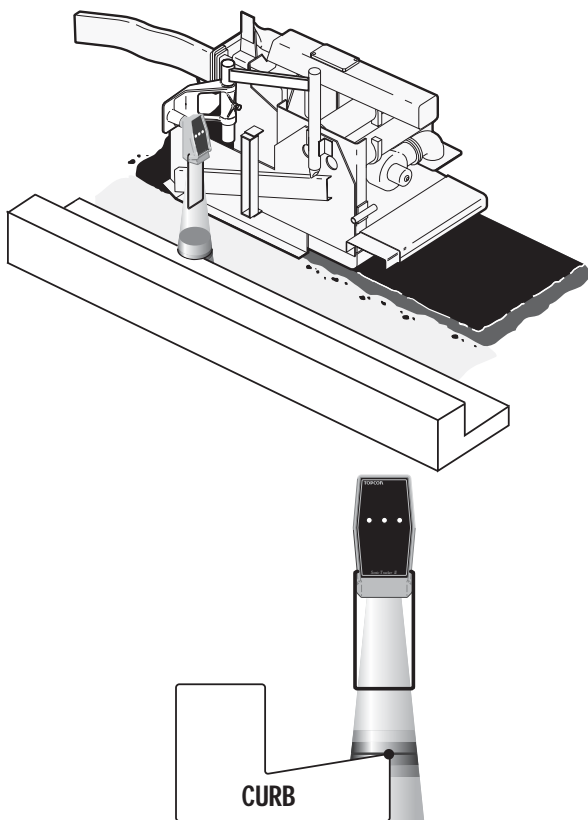

Figure 6-3. Position of L-Bar with Tracker on Bracket

## Curb and Gutter Tracking

When tracking a curb and gutter, keep the tracker 14 to 24 inches above the lip of gutter (Figure 6-4). If the tracker is placed too high, the sonic cone may pick up an unwanted surface, such as the face of the curb.

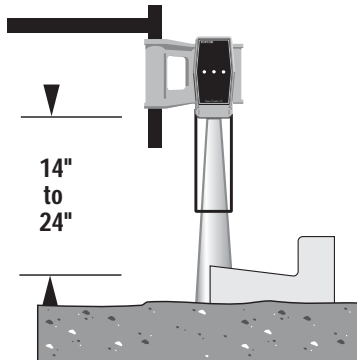

Figure 6-4. Tracking a curb & Gutter

## Joint Matching and Tracking Sub-grade

For joint matching and tracking sub-grade or most surfaces keep the tracker between 14 to 24 inches (Figure 6-5). A good rule of thumb is to set the tracker about 18 inches from the reference.

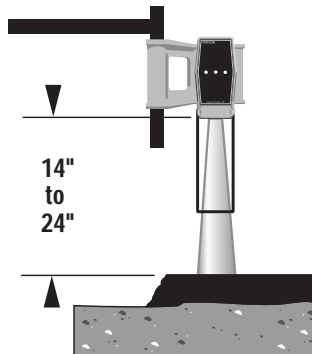

Figure 6-5. Joint matching & Tracking Sub-Grade

## Placement When Using a Temperature Bail

Temperature and atmospheric conditions will have an effect on the speed of sound. In paving applications, you can get a dramatic and rapid change in air temperature. A temperature bail is attached to the tracker to compensate for these variations. If you are on a job where there are high winds and/or large temperature fluctuations, lower the tracker closer to the reference (Figure 6-6).

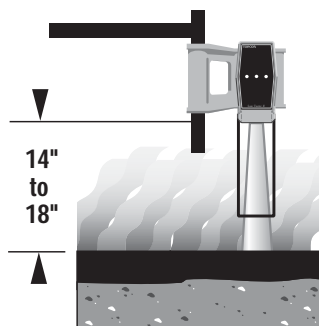

Figure 6-6. Temperature Conditions and Tracker Placement

## Placement When Using a Mechanical Ski

If using a mechanical ski with an elevated string or wire, make sure the string/wire reference is a minimum of 4 inches above the ski (Figure 6-7 on page 6-7). When paving with a mechanical ski through super elevations, the ski will tend to pull away from the paver and may even tip to one side. Elevating the string at least 4" will ensure the ski stays out of the working window.

Also, remember to place the tracker in the center of the ski to maximize the averaging length. If using a 30' ski, the sensor should be placed 15' from the end of the ski. For every 1' positioning error from the center of the ski, you lose 2' of effectivity of the ski. For example, if the sensor is moved forward or backward 2 1/2' (12 1/2' from the end) you are using a 25' ski.

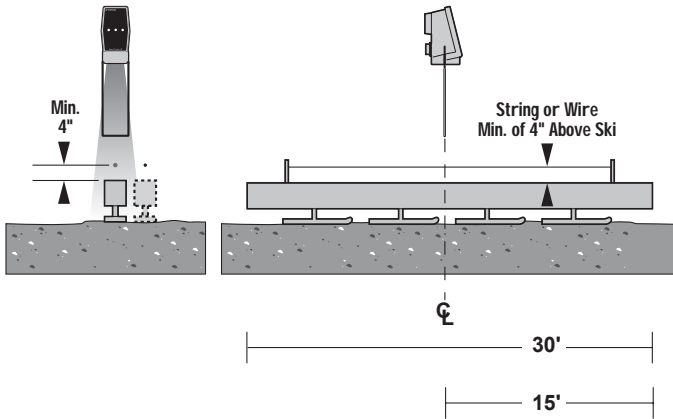

Figure 6-7. Tracker & Mechanical Ski Placement

## Placement When Using Elevated Stringline

Some jobs may require the mat be laid to a specified elevation. In an application like this, an elevated stringline or wire may be set up. The sonic tracker has a built in working window that will prevent the screed from diving if the tracker loses the stringline reference. Position the tracker over the stringline and set the distance between 18 and 24 inches (Figure 6-8).

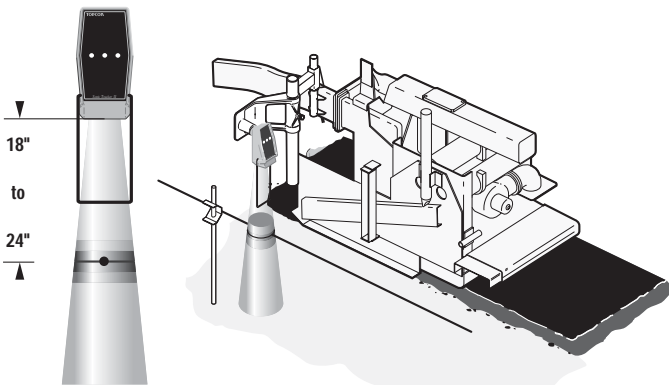

Figure 6-8. Tracker Position – Mat laid at Specific Elevation.

## Placement When Using Surface Stringline

Sometimes the surface to be paved contains pot holes or the surface is too broken up to use as a joint match reference. Setting an elevated stringline is too time consuming, especially for small, divided up projects. In these applications, surface stringline would be a good alternative (Figure 6-9). See “Setting Surface Stringline” on page 3-2 for further details.

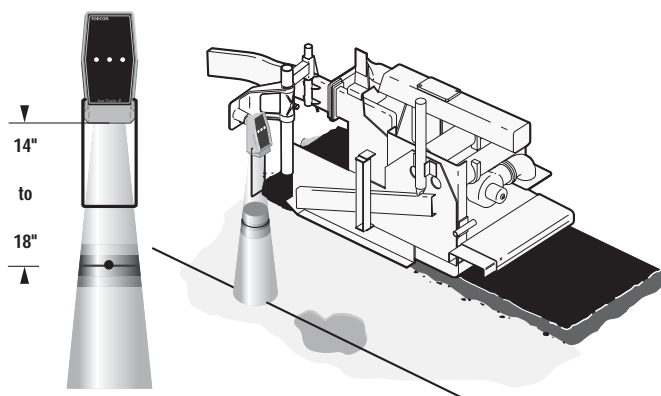
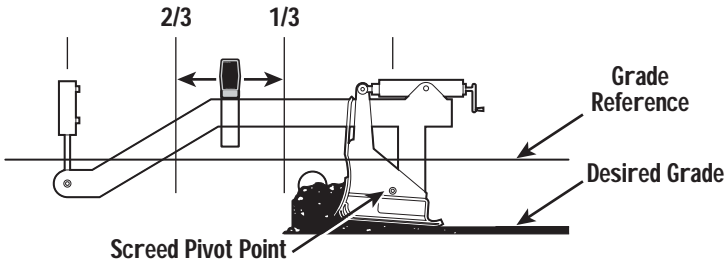

Figure 6-9. Tracker Placement – Pot Holes

## Sonic Tracker Placement in Relation to Screed

As a tracker is moved closer to or further away from the screed, the response of the screed to an elevation correction changes. A rule of thumb is to place the tracker about  $1/3$  to  $2/3$  the length of the tow arm forward of the screed pivot point (Figure 6-10 on page 6-9).

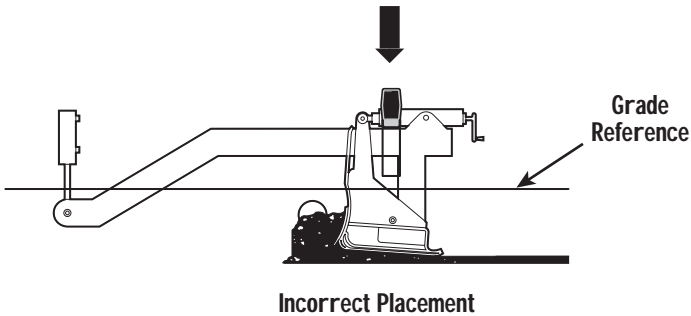

**Figure 6-10. Correct Tracker Placement in Relation to Scream**

If the tracker is not placed between these points, then incorrect screed responses could result. The following examples describe the possible, incorrect placements and the errors that would occur.

- **Example 1: Tracker Placed Incorrectly at Scream Pivot Point**

If the tracker is placed directly at the screed pivot point (Figure 6-11), you can see exactly where the screed is relative to the grade reference. However, there will be no feedback from the tow point cylinder, which is used to make the grade control changes.



**Figure 6-11. Incorrect Placement at Scream Pivot Point**

If the tracker gets closer to the reference, it sends a raise correction signal to the valve and the tow point cylinder begins to move up. Because the screed floats, it does not react

immediately to the tow point movement, so the tracker continues to send raise correct signals to the valve. By the time the screed gets to grade (approximately 3 tow arm lengths), the tow point cylinder has moved too far, causing the screed to continue raising. The tracker senses this over correction and sends a lower signal to the tow point cylinder, repeating the whole process in the other direction. Therefore, with the tracker mounted at the screed pivot point, long waves in the mat will be produced because there is no feedback from the tow point cylinder to the screed (Figure 6-12).

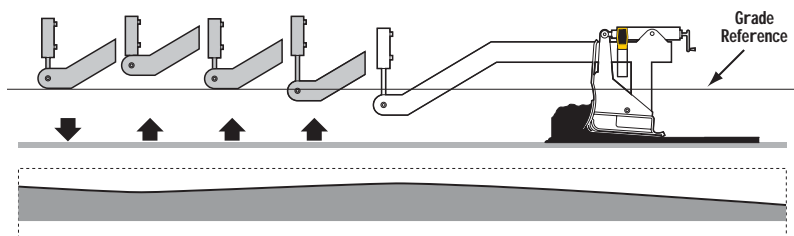

Average profile of mat with Sonic Tracker™ mounted at Screed

**Figure 6-12. Tracker at Screed Pivot Point Causes Erroneous Corrections**

- **Example 2: Tracker Placed Incorrectly at Tow Point**

At this point, where grade corrections are being made, the sonic tracker is kept at an exact distance from the grade reference (Figure 6-13 on page 6-11). Any tracker elevation changes will cause the tow point cylinder to move immediately. The problem with the tracker placed here is the lack of feedback from the screed.



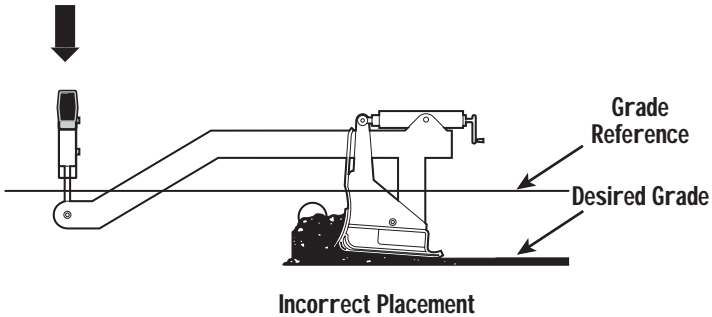

**Figure 6-13. Incorrect Placement of Tracker at Tow Point**

If any of the forces acting on the screed change, then the screed will rise or fall without the tracker sensing the movement. For example, if the amount of material in front of the screed was decreased, the head of material force (“M”) also decreases and the screed would begin to fall (Figure 6-14). However, the sonic tracker would keep the tow point cylinder on grade, but not the screed since there is no feedback.

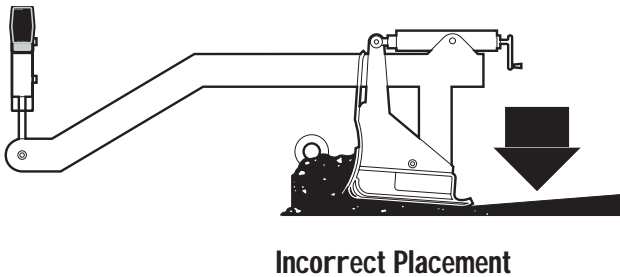

**Figure 6-14. Tracker at Tow Point Causes Erroneous Corrections**

The best place for the tracker is in the 1/3 to 2/3 zone, but where do we position the tracker within that area? That depends on what end result of paving you are trying to achieve. As the tracker is moved further back towards the screed it becomes more reactive. At the 1/3 point a 1/4 inch correction at the tracker will cause a 3/4 inch correction at the tow point (Figure 6-15). Another way to look at it is the “Net Tow Arm Length”.

A paver with a 9 foot tow arm and no sonic tracker will take 27 feet (9 feet x 3 tow arm lengths) to see 96% of the elevation change. If a tracker is placed at the 1/3 point, or 3 feet in front of the screed pivot point, then the paver must move 9 feet (3 feet x 3 tow arm lengths) for 96% of the elevation change. The tracker is measuring the distance to the reference, so its position along the tow arm becomes the “net tow arm length”. A more reactive screed would be beneficial for applications where it is important to match the reference, such as tracking a curb and gutter or matching a joint.

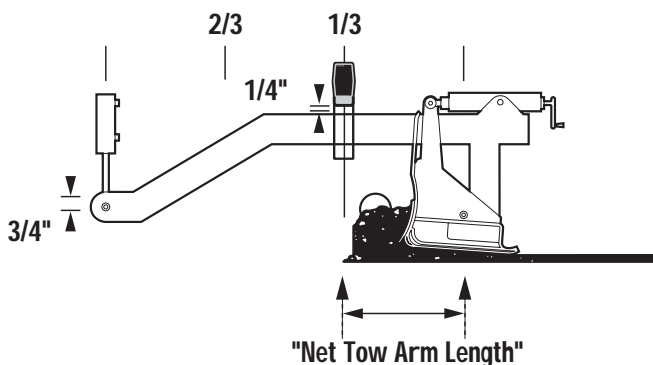
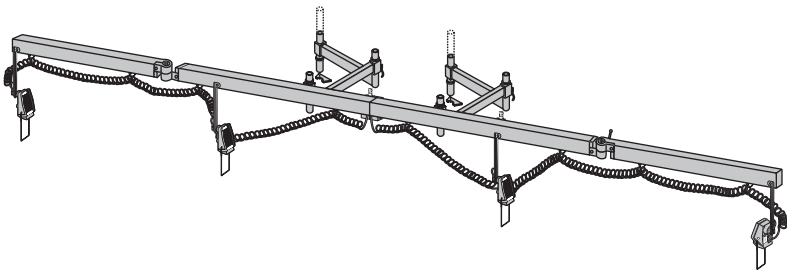

**Figure 6-15. Correct Placement of Sonic Tracker**

As the tracker is moved further forward the screed becomes less reactive. A tracker placed at the 2/3 point and looking for a 1/4 inch correction will only cause the tow point to move 3/8 inch. The net tow arm length is now 18 feet (6 feet x 3 tow arm lengths). This would be a better tracker position for applications where smoothness is desired such as mainline paving or when using a mechanical or non-contacting (SAS) ski.

## Smoothtrac SAS Placement and Setup

Topcon's Smoothtrac® Sonic Averaging System (SAS) is a non-contacting averaging system that uses multiple sonic trackers to smooth out the bumps and dips in a mat surface (Figure 6-16). The non-contacting design allows full maneuverability of the paver when turning around, backing up or passing over obstacles without lifting or removing the beam. The screed man can adjust mat thickness on the control box while standing on the screed. The Smoothtrac is mounted to the tow arm of the paver, and connects to System Five with the same coil cord used for the Sonic Tracker.



**Figure 6-16. Smoothtrac SAS**

When mounting the SAS to the paver, follow these simple steps:

1. If the ski is in pieces, connect them together (Figure 6-17).

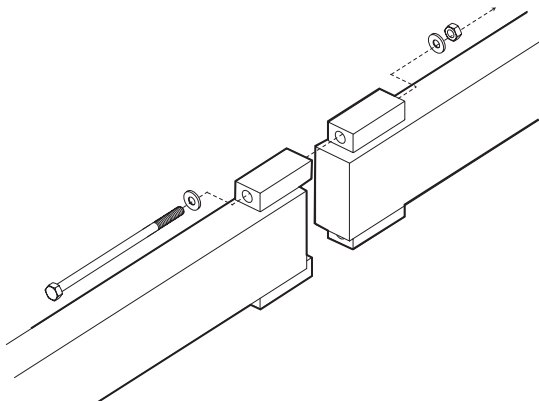
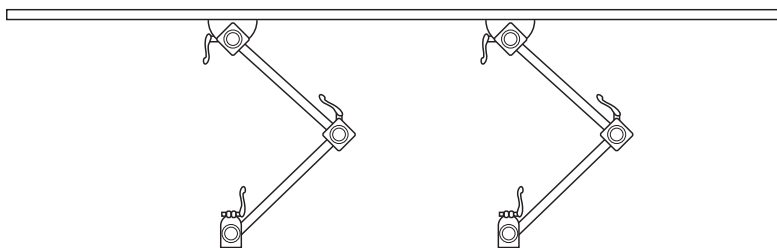

**Figure 6-17. Connecting SAS Pieces**

2. Next, mount the L-bars to the brackets on the tow arm. The outside L-bar can be attached so it points up or down. The position will depend on how tall the tow arm is off the ground.
  - For pavers with a tall tow arm, mount the L-bar in the downward position.
  - For shorter tow arms, mount in the upward position.

Place locking collars on the bars and adjust so they are parallel with one another before tightening with an Allen wrench. This will allow the ski to move freely when adjustments need to be made without falling off.

3. Bend the L-bars so they are aligned in the same position and fold inwards so they are close to the paver (Figure 6-18). Make sure the clamp handles are loose so the bars can move.



**Figure 6-18. Position of L-bars**

4. Lift the ski and slide it over the L-bars. Adjust the ski so it is approximately 2 1/2 feet off the ground. Slide the locking collar up to the ski and lock in place.



### TIP

The ski will be easier to mount if the end beams are folded in. Bend the L-bars so they are aligned in the same position and fold inwards so they are close to the paver. Make sure the clamp handles are loose enough so bars can move.

- Lower each of the Tracker hangers on the SAS and mount a Sonic Trackers using the L-handle bolt (Figure 6-19). An extra washer may need to be added so the L-handle does not block the cable connection.

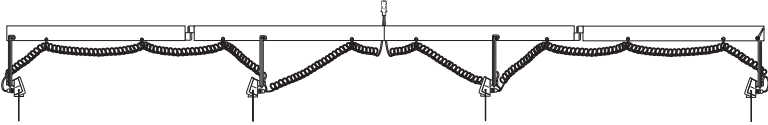

**Figure 6-19. Mounting Sonic Trackers to SAS**

- Connect the SAS coil cable to each tracker (Figure 6-20). Make sure to loop the coil cable through the U-hangers to keep it from getting damaged.

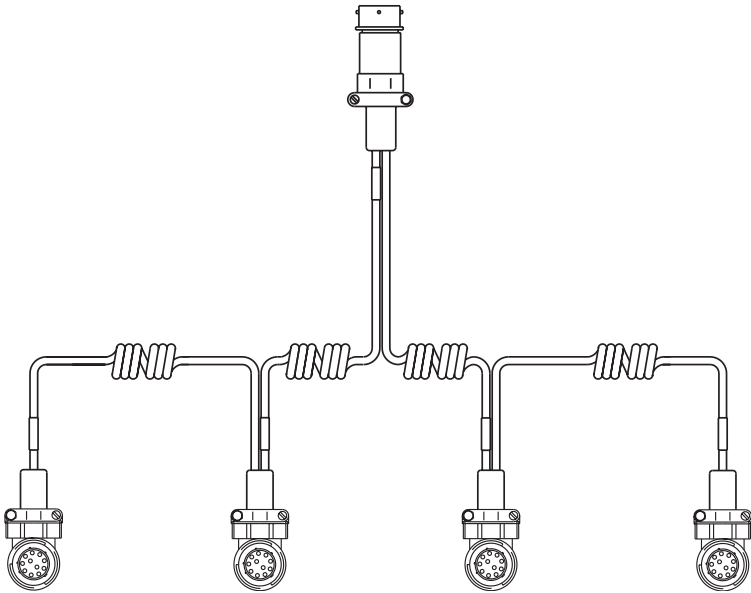

**Figure 6-20. SAS Cable Connectors to Sonic Trackers**

- Attach temperature bails to each tracker and begin paving.

## Positioning the SAS

The SAS should be positioned so the Sonic Trackers are 14 to 24 inches from the grade reference (Figure 6-21). As with single tracker operation, the “lower the better” is a good rule of thumb for paving applications. This will help minimize the variable temperature conditions that can cause erratic signals. The beam does not have to be perfectly level because each tracker averages the distance to the reference individually.

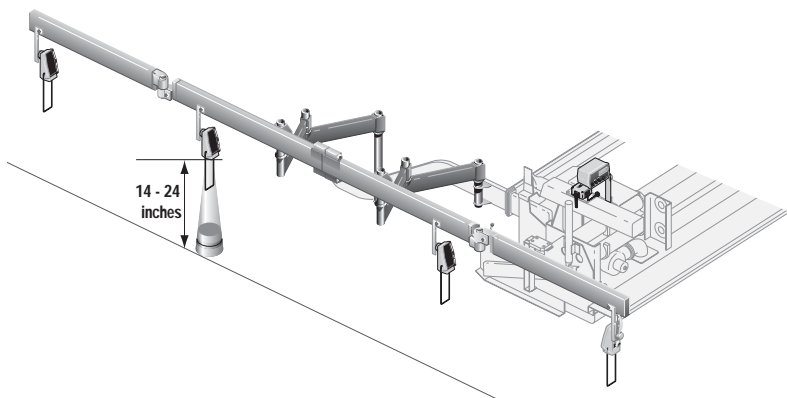
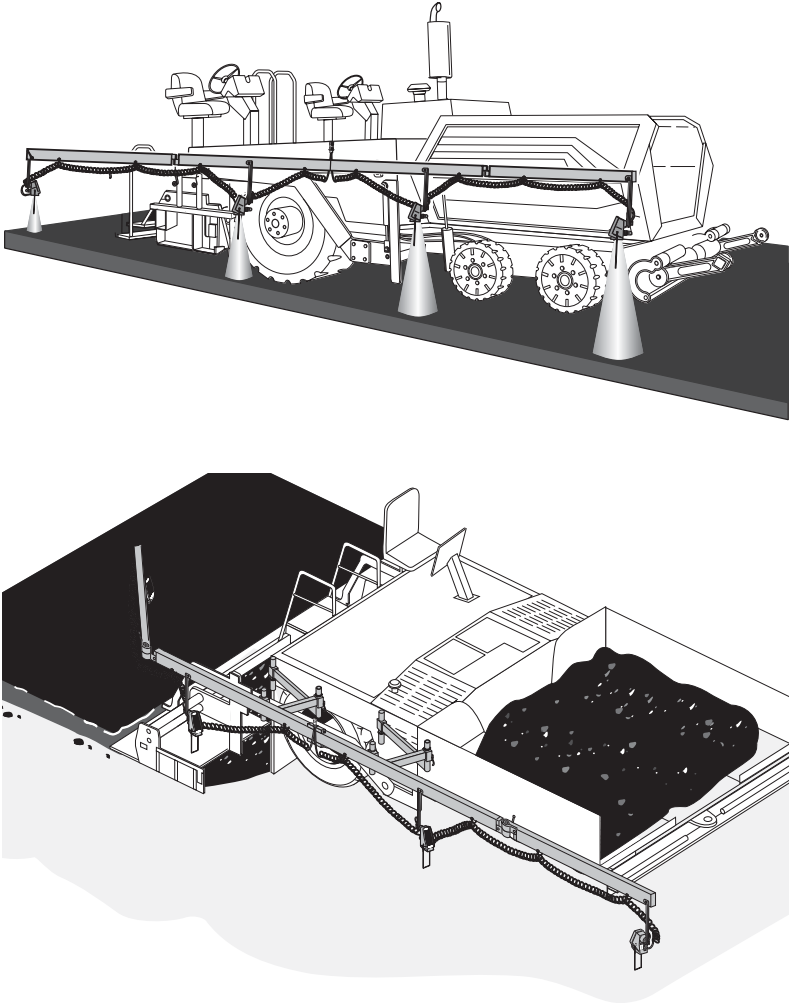

Figure 6-21. Positioning SAS

With SAS, be careful when the screed is raised that the front tracker does not hit the ground. If needed, the tracker bracket can be folded back when raising the screed to keep the tracker from hitting obstructions.

The trackers can be placed so all four are over the reference, or the back tracker can be set over the freshly laid mat. The best method is the one you are presently using or the one in which you are most comfortable (Figure 6-22 on page 6-17).



**Figure 6-22. Example Placement of SAS Trackers Over Reference**

In some applications, a grade reference outside the screed extension may not be in satisfactory condition, such as the shoulder of a road or the broken and warped edge of pavement. Traditionally, the screedman would manually adjust mat thickness on that side of the paver. The non-contacting SAS can be set up over the screed so full automation can be used. The first three trackers will reference the existing grade and the back tracker will reference the mat just laid (Figure 6-23).

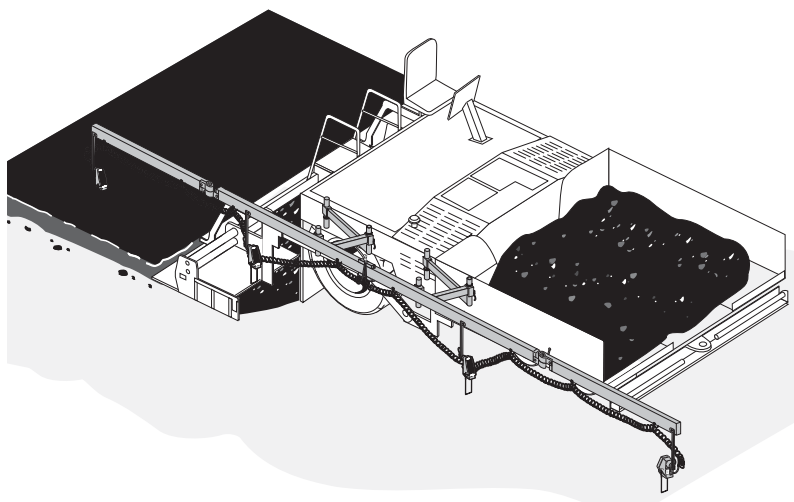

**Figure 6-23. SAS Setup when Screed Extension is Unsatisfactory**

When paving with the screed extensions out, there may be a large “head of material” which could be picked up by the Sonic Tracker. If this happens, determine how far forward the tracker must be placed on the beam to not pickup the mix and drill a new mounting hold for the tracker hanger (Figure 6-24 on page 6-19). The SAS coil cable will easily reach the tracker.



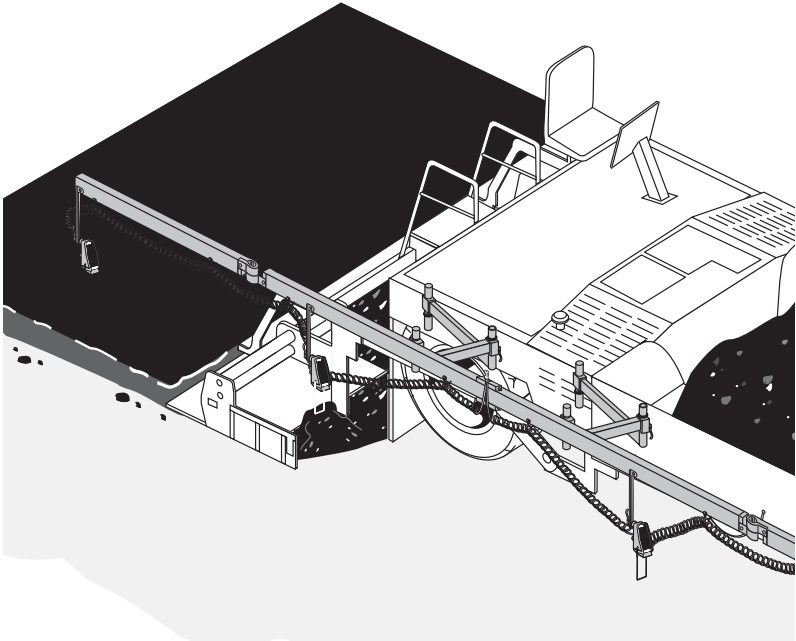

Figure 6-24. Repositioning the Sonic Tracker

## Placement of SAS on Paver

The center connection point of the SAS is the balance point. The position of the balance point to the tow arm is very critical. By moving the balance point, the performance of the system is greatly affected. The balance point of the beam should be located  $1/3$  to  $2/3$  the distance from the pivot point of the screed to the tow point cylinder.

Placing the balance point closer to the  $2/3$  point (near the tow point cylinder), will cause the system to have a slower reaction time. This would be good for smoothness or for mainline paving. Placing the balance point near the back  $1/3$  (closer to screed) will cause the system to have a faster reaction time. This would be good for a combination of smoothness and joint matching.

To determine where to position the SAS on the paver, start by measuring the length of the tow arm. Divide the total length by three. This will give you the placement of the balance point of the SAS on your machine (Figure 6-25).

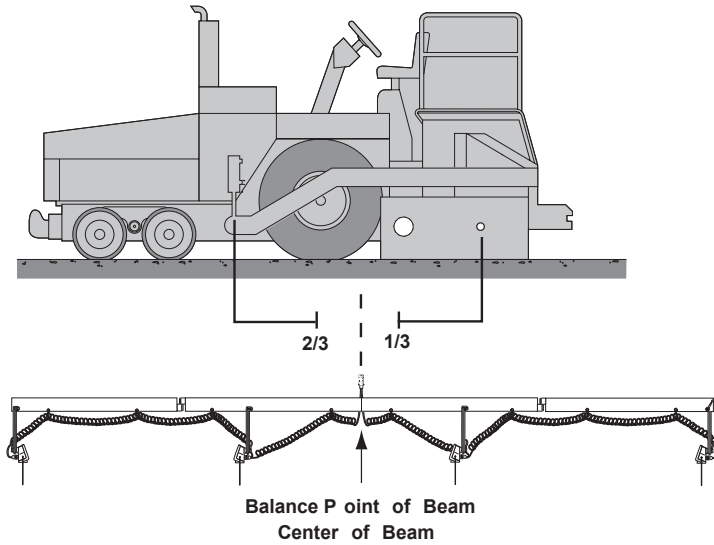

**Figure 6-25. Placement of SAS**

# Paving Applications

What type of controls you should use for paving depends on what result is required for the finish product. Some projects are looking for smoothness and improved rideability. Others are concerned with mat thickness and some require the new asphalt to match curb and gutter or existing grades. Topcon's System Five™ is very versatile and can be used in all these applications. The following are a few examples of what controls might be used and how to set them up.

## Paving City Streets with Sonics

When paving city streets, the general requirement is to lay a mat that is so many inches above the base at the centerline and to match curb and gutter (Figure 7-1). For this application, sonic control will be used on both sides.

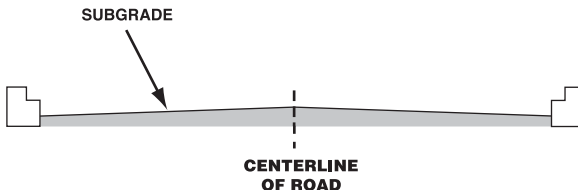

Figure 7-1. Paving to Center Line and to Match Curb

1. Before paving, make sure the machine is properly setup, cross slope is calibrated, and trackers are set in the correct position. See Chapter 5 and Chapter 6 for details.

2. Position right tracker over lip of gutter and left Tracker past the centerline on the base material (Figure 7-2).

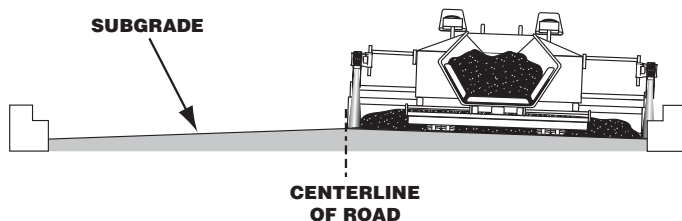

Figure 7-2. Positioning Tracker Over Gutter

3. Turn on the Control Boxes, then Survey and Set the displays to read the depth of asphalt to be laid (Figure 7-3).



Figure 7-3. Control Box Displays – Depth of Asphalt

4. Put both Control Boxes in automatic mode and begin paving. Check the depth of mat at centerline and verify joint matches at lip of gutter. After compaction, make the necessary adjustments at the Control Box.



If the road width varies, it will be easier to keep the Tracker over the gutter if the Tracker is mounted to the extension on the paver.

- To pave the other side of the road, position the left tracker over the lip of the gutter and place the right tracker over the new mat (Figure 7-4).

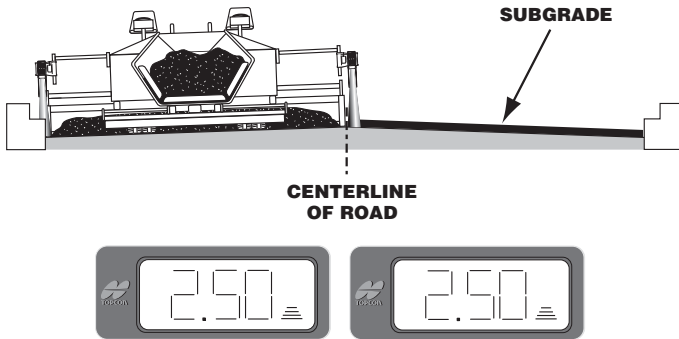

**Figure 7-4. Paving Other Side of Road**

- Survey both Control Boxes on-grade and Set the displays to read the depth of asphalt to be laid. Put the Control Boxes in automatic mode and begin paving. Check to make sure joints match after compaction.

## Paving City Streets with Cross Slope

Another option is to pave the street using cross slope and sonic control. The tracker is positioned over the lip of gutter on one side and cross slope is dialed in for the crown on the other. This method may have to be modified due to the fact that in many cases, the curbs may be poured at different elevations on either side of the street. Even though the curb was poured out of tolerance, it may have passed inspection and the asphalt needs to match the curb and gutter. If the curbs are at different elevations, it is impossible to pave a typical design slope on both sides of the street.

A cross section design of a 36 feet wide street with a 2.0% slope will produce a .36 feet rise at centerline (Figure 7-5).

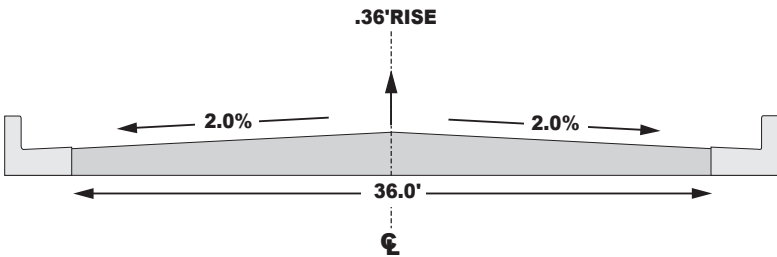

Figure 7-5. Paving with Cross Slope

If the curbs are at different elevations, a .36 feet rise at centerline will produce incorrect slopes (Figure 7-6).

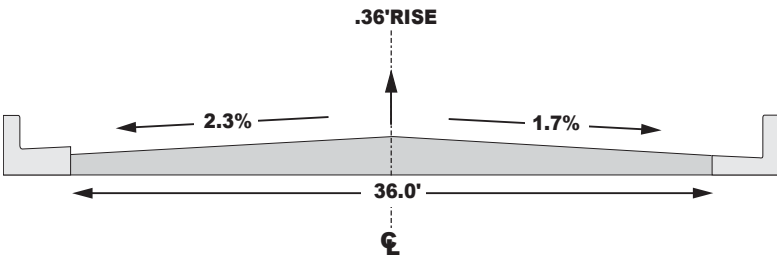

Figure 7-6. Curbs with Different Elevations

When System Five is used to pave a true 2.0% slope, the crown of the street will not be at the centerline (Figure 7-7).

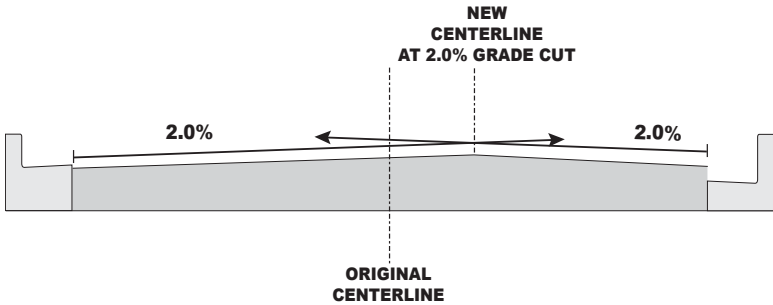

Figure 7-7. Curb with Same Slope

To pave from uneven curbs using slope control, choose the side of the road with the highest curb and position the tracker over the curb. Set the other side for the desired cross slope and begin paving (Figure 7-8).

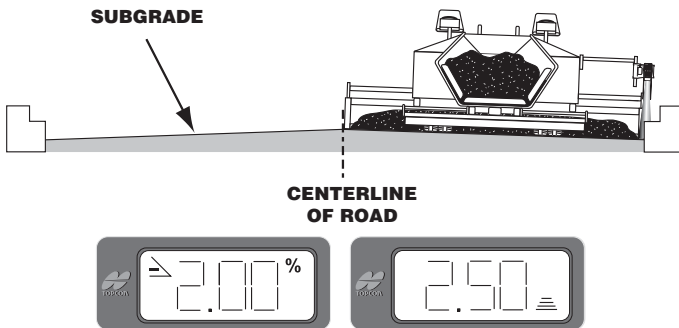
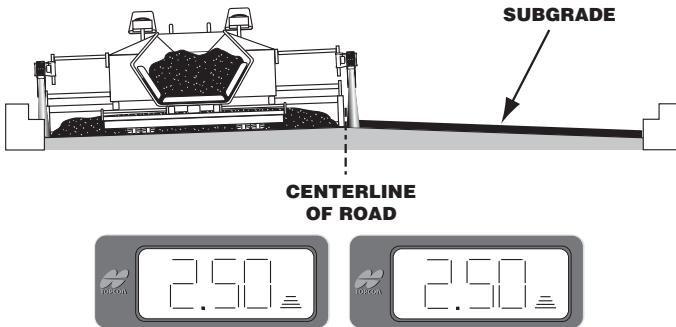

Figure 7-8. Paving Uneven Curbs with Slope Control

To keep the centerline in the middle of the road, the second pass will have to be set up with Sonic Control on each side of the paver. The left tracker will match the lip of the curb and the right side tracker will follow the new mat (Figure 7-9). The cross will not be consistent on this side of the roadway, but the joints will match.



**Figure 7-9. Second Pass when Paving Uneven Curbs**

The curb elevations can be easily spot checked using a fast leveling RL-HB rotating laser. Set the laser at the lip of one curb, then use the detector and a folding rule to take a reading on the other curb (Figure 7-10). Spot check every 25-50 feet by just moving the laser.

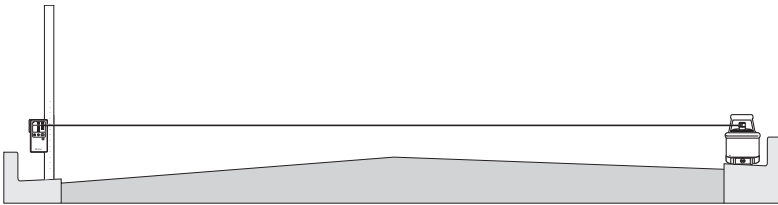

**Figure 7-10. Checking Curb Elevations**



## Paving Streets Through Intersections

As you pave city streets, you will come upon intersections where the curb stops. There are a couple of methods for controlling grade through the intersection.

### Method 1 for Paving Intersections

For this method, the base of the intersecting road will be used as the reference.

1. With both sides in Elevation Control, pave to the intersection (Figure 7-11).

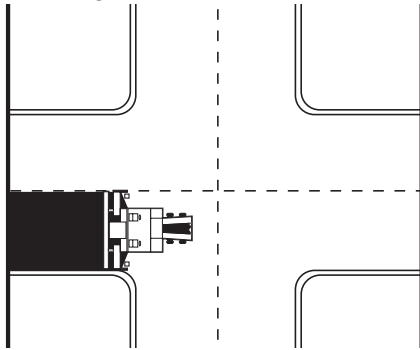

Figure 7-11. Paving Through Intersections

2. Just before the right tracker reaches the end of the curb, press the Auto/manual button to put the Control Box in manual mode (Figure 7-12).

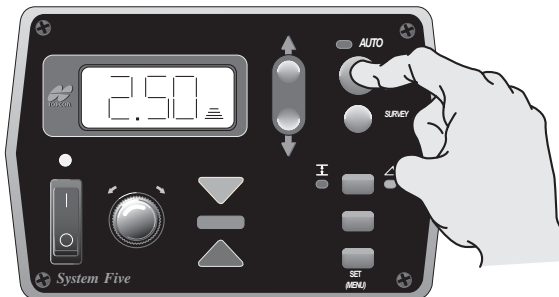
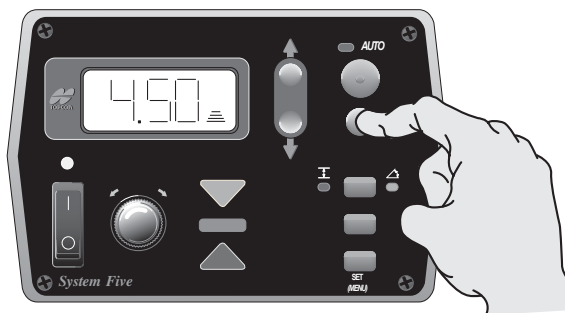

Figure 7-12. Control Box in Manual Mode

- Without stopping, continue paving until the right tracker is on the base material of the intersecting road. Survey the tracker on-grade to the new reference (Figure 7-13) and put back into Automatic Control.



**Figure 7-13. Survey to On-grade and Return to Automatic Control**

- Pave through the intersection, and just before the Tracker reaches the curb on the other side (Figure 7-14), press the Auto/manual button to put the Control Box in manual mode.

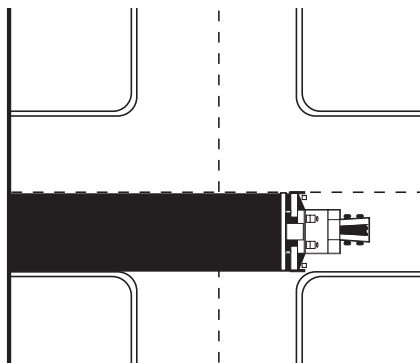

**Figure 7-14. Paving Through Intersection**

- Without stopping, continue paving until the tracker is back on the lip of the curb. Survey the tracker on-grade (Figure 7-15 on page 7-9) and put back into automatic control.

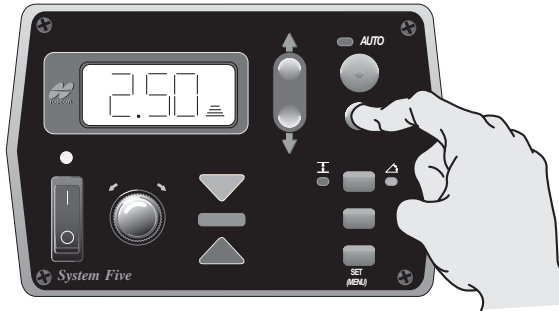

**Figure 7-15. Survey to On-Grade and Return to Automatic Control**

You may find after surveying that for the tracker on the curb the number has changed slightly from the curb on the other side of the intersection. This is due to the different depth of the base below the lip of curbs. While paving, slowly dial the display back to the previous number.

## Method 2 for Paving Intersections

Sometimes, the base of the intersecting road is too rough to use as a reference. An alternative is to use a simple piece of stringline.

1. Take a section of 1/8" diameter string and nail or secure it to the curb.
2. Pull the string tight through the intersection and nail or secure it to the other curb (Figure 7-16 on page 7-10).



If the intersecting road has a crown, hike the stringline up in the middle of the road to place the string at the proper height. A hub or a stake with a piece of wire to hold the stringline works fine.

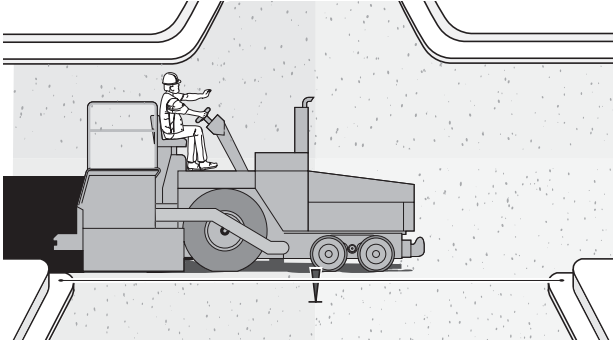

Figure 7-16. Paving Through Intersection Using Hub

This constant reference will give you complete control through the intersection and will also ensure that you tie in perfectly to both curbs.

## Paving Intersections with Cross Slope

When paving with slope, intersections do not require any adjustments if the “mainline” cross slope does not change. If the slope does change, then a combination of slope and Tracker should be used (Figure 7-17).

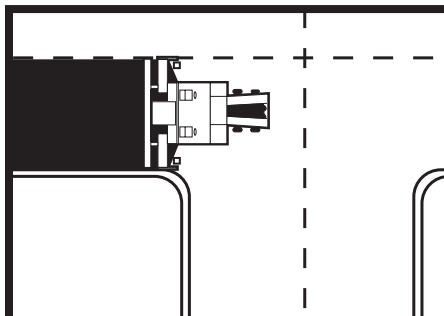
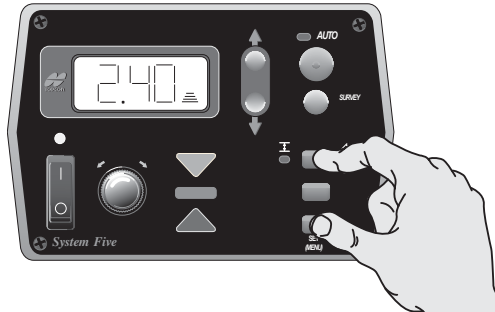

Figure 7-17. Paving Intersections with Cross Slopes

1. Put the slope side of Paver in manual mode just before the slope of the intersection begins to change (Figure 7-18).



**Figure 7-18. Switching to Elevation Control and Surveying On-grade**

2. Switch from slope to elevation control on the Control Box and Survey the tracker on-grade (Figure 7-19).

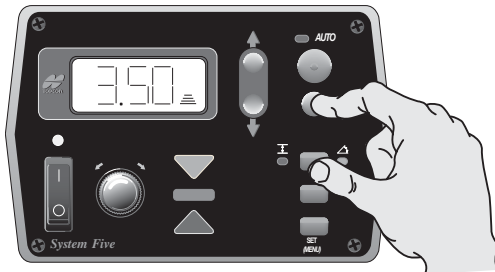

**Figure 7-19. Surveying Tracker to On-grade**

3. Pave through the intersection with the Sonic Tracker in automatic.

4. Upon reaching the end of the intersection (Figure 7-20), put the Control Box back in manual mode, change to slope control, and Survey the slope to get an on-grade signal (Figure 7-21).

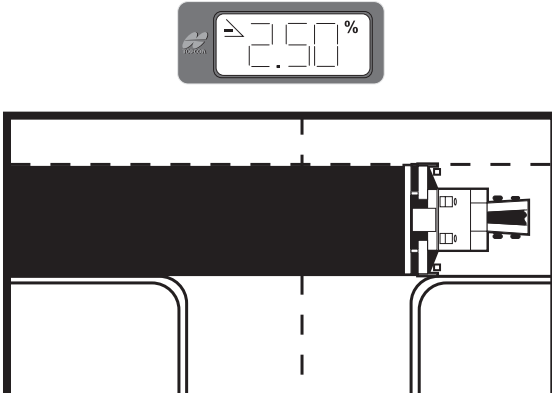

Figure 7-20. Paving Through Intersection

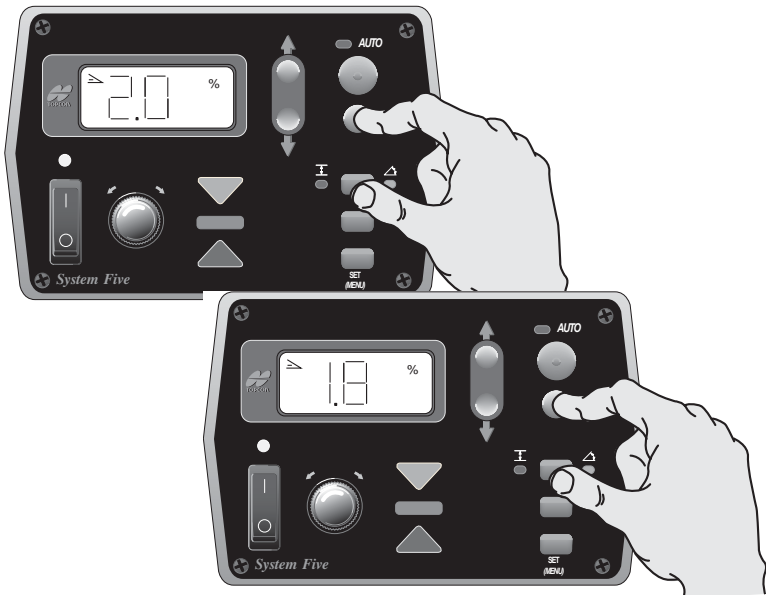

Figure 7-21. Returning to Manual and Surveying On-Grade



## NOTICE

*You may find after surveying the slope that the number displayed is not the same as the desired cross slope. This will occur if the surface being paved is not also at the desired slope. To get back to the correct slope continue paving in automatic and slowly dial the display to the desired slope. Failing to survey when changing back to slope control could result in a bump in the mat.*





# Maintenance

This section contains information regarding preventative maintenance and daily care of System Five™. Also included are:

- Cleaning procedures for the Sonic Tracker II™ Transducer.
- Replacement procedures for the Sonic Tracker II Transducer.

## **Preventative Maintenance & Daily Care**

A good preventative maintenance and daily care routine will prevent many problems before they occur. The most important part of daily care for System Five™ is to clean it and keep it free of debris, and to thoroughly dry removable components (Sonic Tracker II™, the Control Box, and cables) before storing them in the Carrying Case. In addition, the following procedures will ensure trouble free operation:

1. Keep the Carrying Case clean and dry. Do not leave it open and exposed to the elements. Clean and dry all components prior to placing them into the Carrying Case.
2. Be sure cables left on the paver are attached to protective connector caps, not in use. Water accumulating on the connectors can cause electrical shorts.

3. Do not use high pressure spray water steam cleaner hoses directly on cables and components. The components can be used in the rain or light spraying.
4. Check the Sonic Tracker II™ Transducer daily to make sure the Filter Foam and Transducer are clean and free of debris. If the Filter Foam is clogged with dirt, replace it. If the Transducer appears to be covered with debris and performance is being affected (see Sonic Tracker II™ in Chapter 2: Operation) clean or replace Sonic Tracker II™ Transducer using the steps listed later in this chapter.

## Sonic Tracker II Transducer Cleaning

### NOTICE

*This procedure is not meant to be a regular maintenance procedure. Clean the Transducer only when contamination is suspected or evident.*

### NOTICE

*Cleaning the transducer too much will result in a shortened Transducer life and/or water damage to the Sonic Tracker.*

1. Hold the Sonic Tracker II™ in an upright position to prevent moisture from inadvertently entering the Sonic Tracker.
2. Mix a mild detergent with water and place the mixture in a spray bottle (use Simple Green® where available).
3. With the Sonic Tracker upright, thoroughly spray the Transducer with the detergent solution.

4. After spraying the Transducer with the detergent, fill the spray bottle with clean water and rinse any residual detergent off of the Transducer.
5. Allow the Sonic Tracker to thoroughly dry.

## Sonic Tracker II Transducer Replacement

If the ability of the Sonic Tracker II to “see” a sonic stringline or other reference continues to be impaired, the transducer may be damaged and needs replaced.

1. Remove and discard the Filter Foam—a new filter foam is provided in the Transducer Replacement Kit (Figure 8-1).

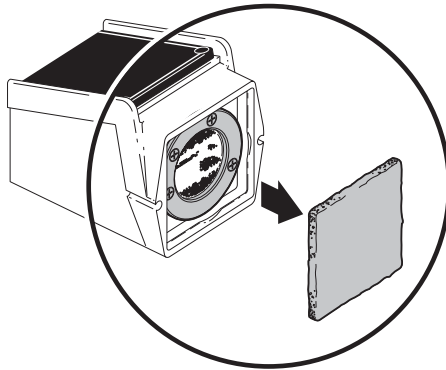

**Figure 8-1. Remove Filter Foam**

2. Remove the four screws and the black retaining ring. Remove and discard the “O”-Ring (Figure 8-2 on page 8-4).

### **NOTICE** NOTICE

*Always remove and discard used “O”-Rings. Used “O”-Rings are distorted and can lose elasticity due to weather or exposure to diesel fumes.*

The Transducer Replacement Kit includes an “O”-Ring and four replacement screws; however, use the original screws and keep the four supplied in the kit for replacements in the event one or more are lost.

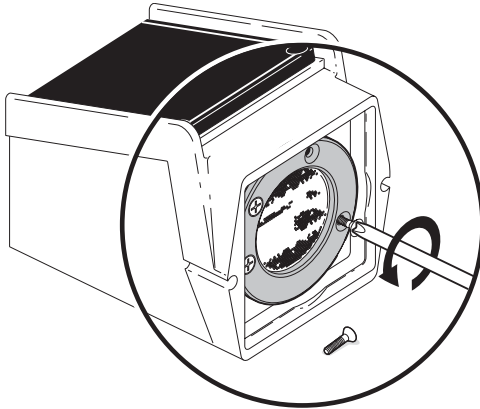
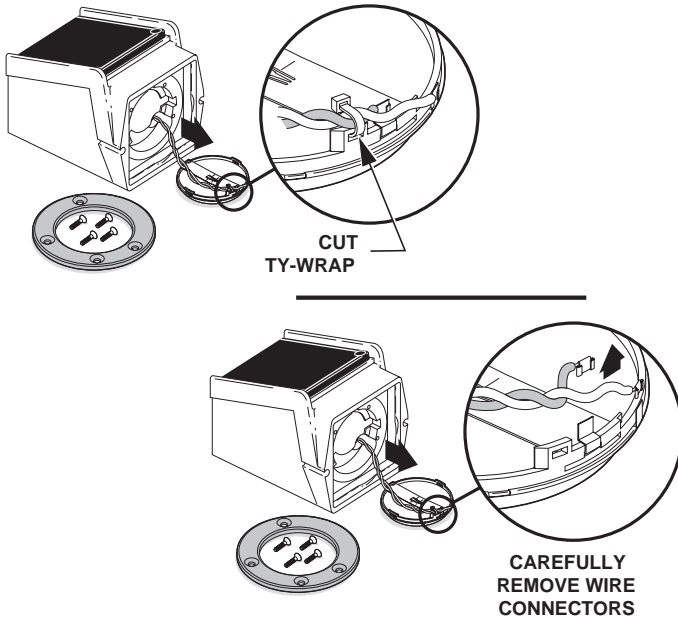

**Figure 8-2. Remove Screws, Retaining Ring, and “O”-ring**

3. Gently pull out the transducer and use a SMALL pair of dikes to gently cut the Ty-Wrap, then remove the small wire connectors from their tabs (Figure 8-3 on page 8-5).

**NOTICE** NOTICE

*When cutting the Ty-Wrap, be careful not to cut or damage the wires.*



**Figure 8-3. Remove Transducer, Cut Ty-Wrap, and Remove Connectors**

4. Place the wire connectors of the new transducer firmly on their tabs; the gray wire connector is placed on the elevated tab. Place the Ty-Wrap in the slot next to the elevated (gray wire) tab, tighten and trim. **DO NOT** pinch the wires (Figure 8-4 on page 8-6).

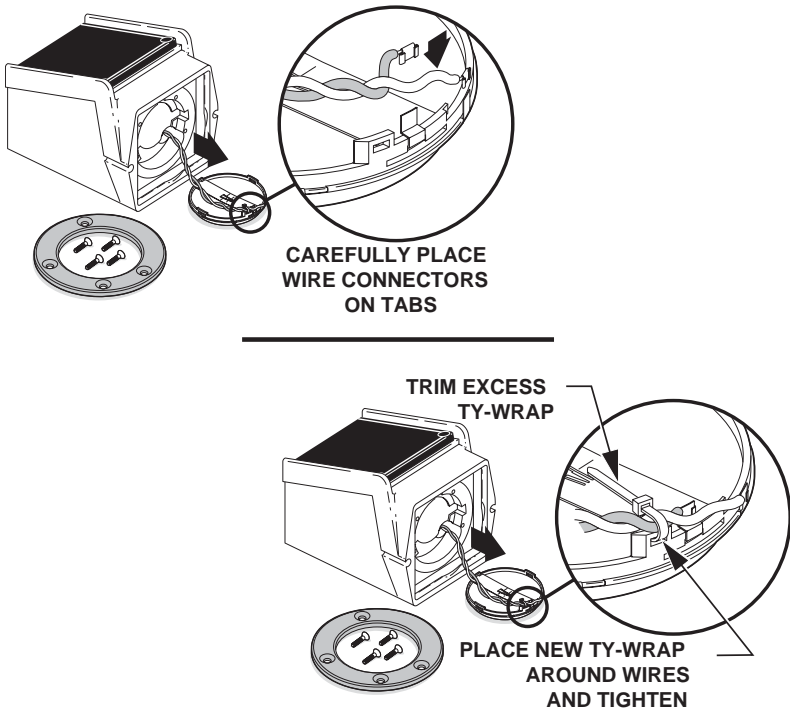

**Figure 8-4. Replace Transducer, Connectors, and Ty-Wrap**

5. “Feed” the wires back up into the Sonic Tracker II and seat the transducer into place (the two wire tabs have to sit down into the extra deep area of the recess). Place the new “O”-ring around the transducer and seat firmly between the transducer and the Sonic Tracker II transducer recess (Figure 8-5 on page 8-7).

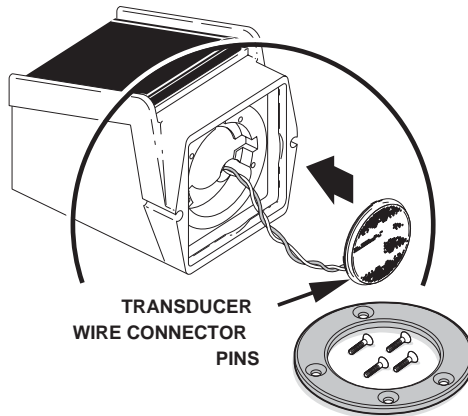

**Figure 8-5. Replace Wires, Transducer, and “O”-ring**

6. Place the black retaining ring over the transducer assembly with the beveled edges out and the flat surface against the Sonic Tracker II base. Line up the holes for the mounting screws. The mounting screw holes are set to an irregular pattern, ensuring the retaining ring only lines up with the mounting holes one way (Figure 8-6 on page 8-8).
7. Start the mounting screws into the holes and tighten each until firm (Figure 8-6 on page 8-8). **DO NOT OVER TIGHTEN.** Use a cross (X) pattern when tightening the screws.

**NOTICE**

**NOTICE**

*DO NOT use Loctite® on the mounting screws. Loctite® will attack and degrade the plastic retaining ring.*

**NOTICE**

**NOTICE**

*Over tightening the screws can distort the transducer metallic material and may crack the*

*retaining ring. The “O”-ring provides tightness while preventing vibration from loosening the mounting screws.*

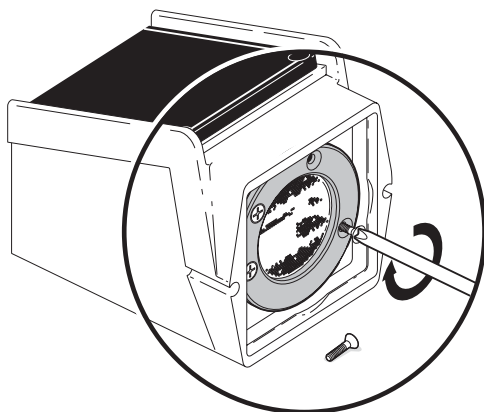

**Figure 8-6. Replace and Tighten Mounting Screws**

8. Ensure the metallic surface inside the transducer has no visible wrinkles. If distortion is evident, repeat steps 5 on page 8-6 to step 8.
9. Place a new filter foam over the transducer. The Sonic Tracker II is now ready for operation.



# Troubleshooting

## Control Box Symptoms

1. Control Box LCD does not Display
2. Control Box LCD displays “Error”
3. Cannot adjust to On-Grade when Elevation Control is selected.
4. Tow point cylinder does not move Up or Down
5. Tow point cylinder moves in the wrong direction
6. Tow point cylinder moves too fast or too slow.
7. System intermittently drives the cylinder all the way up or down when tracking a mechanical ski.
8. Control Box displays Error and a number from 1 to 4
9. Grade lights flash high and low and will not stay On-Grade.
10. The valve is driving the hydraulic cylinder too far overshooting grade.
11. The valve will not drive hydraulic cylinder far enough to get sensor On-Grade.
12. The Control Box displays “No Signal” when indicate is selected in elevation mode.
13. The Auto light on the Control Box intermittently flashes on and off.

## Control Box Symptom 1

“The Control Box LCD does not display.”

### Probable Cause

No power to the Control Box.

1. Check that the machine power is on and all switches for automatic control on the paver are in the proper position.
2. Check that all cables are properly and securely connected to the System Five™ Box and the paver. Make sure cables are not still connected to Control Box bracket.
3. Disconnect cables and inspect them for damage or contamination. Clean all connections with an electrical contact cleaner.



### NOTICE

*Do not use electrical contact cleaner to clean the Tracker's transducer.*

4. Swap Control Boxes from left to right side.
5. For System Four™ bypass Junction Box by plugging coil cord from paver to J-Box directly into Control Box.

## Control Box Symptom 2

“Control Box LCD shows Error” (Figure 9-1).

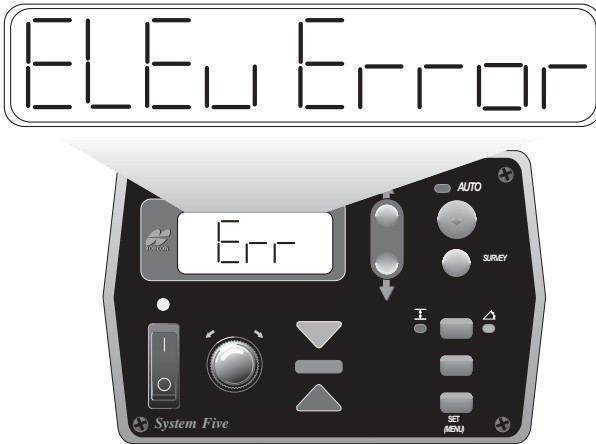

Figure 9-1. Error Display

### Probable Cause

No communication with the sensor selected.

1. Check that all cables are properly connected to System Five™ Control Box and sensors.
2. Disconnect cables and inspect them for damage or contamination. Clean all connections with an electrical contact cleaner.



### NOTICE

*Do not use electrical contact cleaner to clean the Tracker's Transducer.*

3. If elevation has been selected, one at a time, swap the Sonic Tracker II™ and cables from the opposite side to locate the error.
4. Refer to Tracker Symptom #1.

5. If slope has been selected, check that slope has not been selected on the other Control Box. Only one box at a time can have slope turned on.
6. Swap slope cable from opposite side.
7. Disconnect cable at slope sensor and connect to other side of sensor to check slope sensor pins.

### **Control Box Symptom 3**

“Cannot adjust to On-Grade when elevation control is selected.”

#### **Probable Cause**

Tracker is too close to control reference.

1. Check that the Sonic Tracker II™ is at least 14 inches away from the control reference.
2. Check for unwanted objects within the sonic footprint.
3. Make sure tracker is not positioned in front of a gusty heat source, such as the engine fan exhaust.
4. Stop the paver, make sure the screed is on the ground and turn the vibrators off. Press Survey and hold for 2 seconds. “IND” will display on the faceplate and a number will be displayed on the LCD. The number should stay constant, or change up and down by a few numbers. If the numbers fluctuate significantly then the Transducer is probably weak or damaged.
5. Check for contamination on the Sonic Tracker II™ Transducer or foam filter. Refer to Transducer and Filter Cleaning and replacement information in the Maintenance and Parts section of this manual.
6. Swap the Tracker with the unit on the opposite side.
7. Averaging may be set too low if tracking an uneven reference. Factory setting is 50.

## Control Box Symptom 4

“The tow point cylinder doesn't move up or down.”

### Probable Cause

Machine electrical switches are not in the proper position, or hydraulics to the cylinder are not active.

1. Check that all locking pins have been removed and that all hydraulic blocking valves are in the open and correct position for automatic control. Refer to the paver manufacturer's manual.
2. Check that all machine electrical switches - and in motion circuits are in the correct position for automatic control. Refer to the paver manufacturers manual. Press the jog switch up and down on the Control Box to make sure there is a current going to the valve. Cylinder should move in the same direction the jog switch is pressed.
3. Check that the Auto Switch is in “Auto” and that the Auto Symbol is illuminated on the front panel.
4. Disconnect cables and inspect them for damage or contamination. Clean all connections with an electrical contact cleaner.
5. Swap the Control Box with the unit on the opposite side.
6. If a Control Box is replaced make sure the configuration and performance settings are correct.
7. If a cable is replaced make sure it is the right part number. A cable with the incorrect resistor could set the Control Box to have the wrong configuration.

## **Control Box Symptom 5**

“The tow point cylinder is moving in the wrong direction.”

### **Probable Cause**

Machine is incorrectly wired or hydraulically connected.

1. Check that the machine is properly wired and hydraulically connected to the valve. A raised jog switch should make the cylinder go up, lowering the jog switch should make the cylinder go down.
2. Check that the proper cables have been supplied for your machine.
3. For System Four, if “OIN” setting is in the performance menu, make sure it is in the off position.
4. Make sure the screed lift cylinders are in the float position and not supporting the screed.

## **Control Box Symptom 6**

“The tow point cylinder is moving ‘too fast’ or ‘too slow’.”

### **Probable Cause**

The paving machine's hydraulic flow adjustment is incorrect, or the control box Valve Offsets or Gain Adjustments are not correct.

1. Refer to paver manufacturers recommended flow adjustment setting for the time it takes the hydraulic cylinder to complete a full stroke of travel. Typically between 12 to 15 seconds.
2. Adjust Gain Performance Settings. Factory setting is 25.
3. Adjust Valve Offsets. Refer to Valve Offset section in the Performance Section within this Manual.

## Control Box Symptom 7

“System intermittently drives the cylinder all the way up or down when tracking a mechanical ski.”

### Probable Cause

Tracker is intermittently picking up signals from the ski.

1. Verify string is at least 4 inches above the surface of the ski. Ski will pull away from the paver and can get in Tracker's Working Window if string is too close. Ski will also tilt to one side when traveling through a super elevation or slope transition.
2. For a multi-foot ski, make sure “foot spring pin” is not within the sonic footprint as the ski surges back and forth.

## Control Box Symptom 8

“Control Box displays Error and a number from 1-4.”

### Probable Cause

Defective Sonic Tracker or SAS cable.

1. Check SAS cable connections at each tracker.
2. Turn Control Box off and swap tracker showing the error number (1-4) with another tracker on the SAS. (Tracker number is on the cable at the tracker connector). Turn Control Box on to reset SAS. If the error number (1-4) has changed, the problem is the tracker. If the error number remains the same, the problem is the SAS cable.
3. If more than one error number is shown, check trackers individually by plugging sonic trackers directly into the single tracker coil cord to determine if trackers or SAS cable is source of error.
4. The defective tracker or SAS cable should be repaired, but SAS can still be operated without all four.

Remember balance point will change if a tracker is removed.

## **Control Box Symptom 9**

“Grade lights flash high and low and will not stay On-Grade.”

### **Probable Cause**

If problem is only in automatic mode, then hydraulic Performance Settings are incorrect.

1. Verify paving machines hydraulic flow adjustments (time for hydraulic cylinder to travel full stroke) are set to manufactures recommendations.
2. Check that the Valve Offsets are set correctly.
3. Check that the Gain setting is too high. Factory setting is 25.

If problem is in manual mode, then

1. Verify that temperature bails are clean and securely attached.
2. Verify temperature bail symbol “T” is displayed on face of Tracker. If not clean or replace transducer.
3. Check that Trackers are between 14 and 24 inches from reference.
4. If there are gusty winds, lower Tracker closer to reference. Approximately 14 to 16 inches.
5. Move Tracker away from gusty heat source, such as engine fan exhaust.
6. Verify Tracker is not picking up erroneous signals from undesired reference.  
Example: Head of material, end gate, shoulder grade or material spillage from hopper.
7. If using Stringline, verify line is not bouncing.



8. Check to see if Averaging in Performance Menu is set too low. Factory setting is 50.
9. Check Deadband in Performance Menu is not less than 3mm.

## **Control Box Symptom 10**

“The valve is driving the hydraulic cylinder too far, overshooting grade.”

### **Probable Cause**

Valve Offset in Control Box are set too high.

1. Lower the Valve Offset value till the sensor no longer overshoots grade. Refer to
2. “Setting Valve Offsets” section in this manual.
3. For Servo and solenoid valves lower the value by 2 to 5 numbers, then check the hydraulic performance.
4. For Proportional valves, lower the value by 10 to 15 numbers, then check hydraulic performances.

## **Control Box Symptom 11**

“The valve will not drive hydraulic cylinder far enough to get sensor On-Grade.”

### **Probable Cause**

Valve offsets in Control Box are set too low.

1. Raise the Valve Offset Value till the sensor is driven to grade. Refer to “Setting Valve Offsets” section in this Manual.
2. For Servo and Solenoid valves raise the value by 2 to 5 numbers, then check hydraulic performance.
3. For Proportional valves raise the value by 10 to 15 numbers, then check hydraulic performance.

## **Control Box Symptom 12**

“The Control Box displays ‘No Signal’ when indicate is selected in elevation mode.”

### **Probable Cause**

Sonic Tracker is reporting no echo.

1. Verify that the Sonic Tracker is ticking.
2. Make sure tracker is pointing at a target with the working range, recommended 14 to 24 inches.
3. Transducer may be dirty or damaged. Refer to the Transducer and Filter section within this manual.
4. Power or ground connection at transducer may be loose. Remove transducer and check wires.

## **Control Box Symptom 13**

“The Auto light on the Control Box intermittently flashes on and off.”

### **Probable Cause**

Sonic Tracker is too far from reference for current atmospheric conditions, or Temperature Cutout is too low.

1. Verify that the Sonic Tracker is positioned 14 to 24 inches from the reference. If there are gusty winds lower the Tracker to 14 to 16 inches from the reference.
2. Move Tracker away from gusty heat source, such as engine fan exhaust.
3. Temperature Cutout is set too low. Factory setting is 7. Refer to Technicians manual.

## Tracker Symptoms

1. Sonic Tracker will not power on.
2. Sonic Tracker is ticking, but will not adjust to Grade
3. Tracker grade lights flash high and low and will not stay On-Grade.
4. Sonic Tracker is not matching joint or curb.
5. The Sonic Tracker will pick up the ground, but will not pick up a stringline.

### Tracker Symptom 1

“Sonic Tracker will not power on.”

#### Probable Cause

Defective cable or tracker.

1. Check coil cord is plugged in correctly and securely.
2. Inspect Coil cord for any physical damage.
3. Turn Control Box on and watch the tracker lights to make sure they go through the power up sequence. All the lights on the tracker should flash at once followed by a flash of an arrow pointing to the left. The “T” symbol should also be displayed in the upper right hand corner of the tracker faceplate when a Temperature Bail is attached. If the tracker does not go through this sequence then the tracker is not getting power or is defective.
4. One at a time, swap tracker and then coil cord from opposite side to determine the problem.

## **Tracker Symptom 2**

“Sonic Tracker is ticking, but will not adjust to grade.”

### **Probable Cause**

Tracker is too close to reference, minimum working distance is 14 inches.

1. Tracker is too close to reference point. Position tracker 14 to 24 inches from grade reference.
2. Connect tracker to other side of paver to determine if problem stays with tracker.
3. If problem stays with tracker, clean or replace transducer or foam filter. Refer to the Transducer and filter cleaning and replacement information in the “Maintenance” section of this manual.
4. If problem does not move with tracker, inspect coil cord for damage and swap with cord from other side.

## **Tracker Symptom 3**

“Tracker grade lights flash high and low and will not stay On-Grade.”

### **Probable Cause**

If problem is only in Automatic Mode, then Hydraulic Performance Settings are incorrect.

1. Verify paving machines hydraulic flow adjustments, time for hydraulic cylinder to travel full stroke, are set to manufacturers recommendations. Typically 12 to 15 seconds.
2. Check Valve Offsets are set correctly. Refer to setting valve offsets.
3. Make sure Gain Setting is not too high. Factory setting is 25.

If problem exists in manual mode, then Tracker is setup incorrectly or Performance Settings are incorrect.

1. Verify that temperature bails are clean and securely attached.
2. Verify temperature bail symbol “T” is displayed on face of Tracker. If not, clean or replace transducer.
3. Check that Trackers are between 14 and 24 inches from reference.
4. If there are gusty winds, lower Tracker closer to reference. Approximately 14 to 16 inches.
5. Move Tracker away from gusty heat source, such as engine fan exhaust.
6. Verify Tracker is not picking up erroneous signals from undesired reference.  
Example: Head of material, end gate, shoulder grade or material spillage from hopper.
7. If using Stringline, verify line is not bouncing.
8. Check to see if Averaging in Performance Menu is set too low.  
Factory setting is 50.
9. Check that Deadband, in Performance Menu, is not less than 3mm.

## Tracker Symptom 4

“The Sonic Tracker is not matching joint or curb.”

### Probable Cause

Tracker is too far forward on the tow arm.

1. Position the Tracker at 1/3rd the tow arm length (just in front of auger).
2. Gain for tracker may be set too low. Adjust Gain to a minimum of 25.

3. Brackets and L-bars have not been securely tightened. Also, check for excessive play or slop where tracker is attached to the paver. (Tow arm or end gate.)

### **Tracker Symptom 5**

“The Sonic Tracker will pick up the ground, but will not pick up a stringline.”

#### **Probable Cause**

1. Tracker is too close to a reference or transducer is weak.
2. Verify that tracker is at least 14" from the stringline.
3. Smooth, steel wire is not recommended. Use minimum 1/16" diameter string for elevated stringline or averaging ski. Use 1/8" string for Surface Stringline.

## **Slope Sensor Symptoms**

Cross Slope reads “Error”
Cross slope drives cylinder in the wrong direction
Slope lights flash between raise and lower and will not stay On-Grade.
Cross slope will not lock On-Grade.
Cross slope being laid is not correct.

### **Slope Sensor Symptom 1**

“Cross Slope reads ‘Error’.”

#### **Probable Cause**

Both Control Boxes are selected for slope or have a defective cable.

1. Cross slope operates one side at a time. Verify only one Control Box has been selected for slope.

2. Verify that the slope cable is connected securely and properly.
3. Swap slope cable from other side to check cable.

## **Slope Sensor Symptom 2**

“Cross Slope drives cylinder in the wrong direction.”

### **Probable Cause**

Slope sensor installed incorrectly.

1. Verify the slope sensor is positioned correctly on the transverse beam. “Slope Forward” Decal must be in direction of travel.
2. Check that the machine is properly wired and hydraulically connected to the valve. Raised jog switch should make the cylinder go up, lower jog switch should make the cylinder go down. Refer to the paver manufacturers manual.

## **Slope Sensor Symptom 3**

“Slope lights flash between raise and lower and will not stay On-Grade.”

### **Probable Cause**

Incorrect Performance Setting adjustments or a loose transverse beam.

1. Check Valve Offset for proper operation. Refer to “Setting Valve Offsets” section in this manual.
2. Check gain setting. Factory setting is 25.
3. Slope deadband set too low. Increase Slope Deadband. Factory Setting is .075%.
4. Check for excess vibration in the Transverse Beam due to poor connection at Tow Arm.

5. Make sure slope sensor is mounted directly to the Transverse Beam and is not elevated or supported by additional brackets.

### **Slope Sensor Symptom 4**

“Cross Slope will not lock On-Grade.”

#### **Probable Cause**

Loose Transverse Beam or incorrect Performance Setting adjustments.

1. Verify that the Slope Sensor is not moving or vibrating when trying to survey slope on grade.
2. Slope deadband setting is too low, factory setting is .075%.
3. Stop the paver, make sure the screed is on the ground and turn the vibrators off. Press Survey and hold for 2 seconds. IND will display on the faceplate and a slope value will appear in the LCD. The number should stay constant or change up or down by a few counts. If the numbers fluctuate significantly then the slope sensor is probably the problem.

### **Slope Sensor Symptom 5**

“The Cross Slope being laid is not correct.”

#### **Probable Cause**

Calibration in Slope Sensor is incorrect.

1. Calibrate the Slope Sensor as described in “Daily Cross Slope Calibration” in the Function and Operations section.
2. Check that the Transverse Beam is mounted according to the manufacturer’s instructions and that it is not loose or damaged.



3. Recheck slope using a good reference such as a laser or level. Wait at least 3 tow arm lengths before checking the slope after a change has been made.
4. If the paver's mat thickness controls have been used then the slope calibration may have to be changed. This can occur after “buying back” cylinder.

## SAS Symptoms

When the SAS is connected, control box displays “Error” and a number.
1 Tracker stops working
SAS will not lock On-Grade
SAS is not producing smooth surface
Tracker picking up head of material

### SAS Symptom 1

“When the SAS is connected, the Control Box displays ‘Error’ and a number.”

#### Probable Cause

Defective tracker or cable, tracker with incorrect code.

1. Verify that all trackers are correctly and securely plugged into the SAS cable.
2. Turn Control Box off and move the Tracker to a different position on the SAS cable. Turn the Control Box on to reconfigure SAS. If error number moved positions with the swapped tracker, the tracker is the problem. See Chapter 8 to replace the transducer.
3. Check to see if a Tracker without SAS code is attached to the cable. Verify that the tracker has a SAS compatible decal near the S/N label (Figure 9-2 on page 9-18).

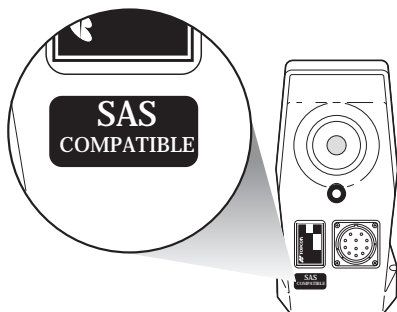

**Figure 9-2. SAS Compatible Decal Location on Sonic Tracker**

4. Tracker can also be checked by verifying code revision. Turn box off and back on. Watch the temperature bail symbol in the top right portion of the tracker (Figure 9-3). The “T” symbol will flash a certain number of times, pause and flash again to indicate the revision of its code.

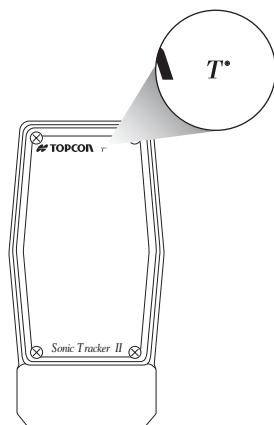

**Figure 9-3. Temperature Bail Symbol Indicating Code Revision**

Example: Flash twice, pause flash twice means the code in the Tracker is 2.2. SAS requires trackers with code of 2.2 or higher.

## **SAS Symptom 2**

“A Tracker stops working.”

### **Probable Cause**

Defective Tracker.

1. Check SAS cable connections at each tracker.
2. Turn off Control Box and swap tracker showing error with another tracker on the SAS. (Tracker number is on the cable at the tracker connector.) Turn the Control Box back on to reset SAS. If error number moved positions with the swapped tracker, then the tracker is the problem. See Chapter 8 to replace the transducer if necessary.
3. If error continues to display for the same position even after trackers have been swapped, the tracker connector or SAS cable is the problem.
4. The defective tracker or SAS cable should be repaired, but SAS can still be operated without all four trackers operating. Remember balance point will change if a tracker is removed.

## **SAS Symptom 3**

“SAS will not lock on grade.”

### **Probable Cause**

Tracker too close to reference or defective transducer in Tracker.

1. Verify that all cable connections are properly and securely connected.
2. Check that all trackers are sending out sound waves (transducer is making ticking sound) and grade lights are flashing.

3. If tracker is not working, check that transducer and foam filter are clean and free from damage. See Chapter 8 to replace the transducer if necessary.
4. SAS beam and trackers may be too close to reference. Bottom of tracker must be minimum of 14 inches from reference.
5. Non-SAS compatible tracker attached to cable. Verify tracker has SAS compatible decal near S/N label (Figure 9-4).

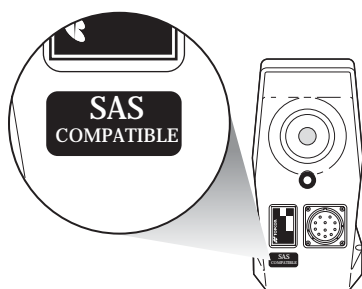

Figure 9-4. SAS Compatibility Label

## SAS Symptom 4

“SAS is not producing smooth surface.”

### Probable Cause

Improper setup or Performance Menu Settings.

1. Verify that temperature bails are clean and securely attached.
2. Verify temperature bail symbol “T” is displayed on face of Tracker. If not clean or replace transducer. See Chapter 8 to replace the transducer if necessary.
3. Check that Trackers are between 14 and 24 inches from reference.
4. If there are gusty winds, lower SAS to get Trackers closer to reference.

5. Move the Tracker away from gusty heat source, such as engine fan exhaust.
6. Verify that the Trackers are not picking up erroneous signals from undesired reference.  
Example: Head of material, end gate shoulder grade or material spillage from hopper.
7. Verify that the center of the SAS beam is between the midpoint and the forward 2/3 point of the tow arm.
8. Check to see if Averaging in Performance Menu is set too low. Factory setting is 50.
9. Check that Deadband in Performance Menu is not less than 3mm.
10. Check that Valve Offsets are set properly.
11. Check that the Gain setting in the Performance Menu is not set too high.  
Factory setting is 25.

## **SAS Symptom 5**

“Tracker picking up head of material.”

### **Probable Cause**

Improper placement of Tracker.

1. Move tracker forward of the material. Rotate Tracker to front of bracket or drill a hole in the beam far enough forward to move tracker away from material.
2. Check balance point. Balance point will shift when moving a tracker.



# Safety Precautions

It is your responsibility to be completely familiar with the cautions described in this manual. These messages advise against the use of specific methods or procedures which can result in personal injury, damage to the equipment, or unsafe operating conditions. Remember, most accidents are caused by failure to observe basic safety precautions.

1. Read and become familiar with the machine manufacturer's operation manual, including safety information before installing, using, or servicing the Topcon System Five.



## WARNING

**Improper operation, lubrication, maintenance, or repair of this product can be dangerous and could result in injury or death.**

2. Use extreme caution on the jobsite. Working around heavy equipment can be dangerous.
3. System Five is externally mounted on the machine. Do not attach Topcon components while the machine is running.
4. Do Not allow any System Five component to limit the visibility of the operator or protrude into traffic.
5. Use Ty-Wraps supplied with the System Five to keep hoses and wires secured and away from possible wear or pinch points.
6. Always wear eye protection when welding, cutting, or grinding on the machine.

7. Protect yourself at all times and wear protective clothing when working on or near hydraulic lines. Hydraulic lines can be under extreme pressure even when the machine is off.



## **WARNING**

**Relieve all pressure in the hydraulic lines before disconnecting or removing any lines, fittings or related components. If injury does occur, seek medical assistance immediately.**

8. Avoid direct eye exposure when using laser control methods.



## **CAUTION**

***DO NOT stare into the laser beam or view the beam directly with optical equipment.***

9. Use appropriate welding precautions and practices when welding. After welding, paint all affected areas with a rust inhibitor.



## **NOTICE**

*Disconnect all TOPCON system electrical cables prior to welding on the machine.*



## **WARNING**

**Do not weld near hydraulic lines or on any equipment when in operation.**



---

 **NOTICE**

*All mounting bracket welds must be secure and strong to prevent sensor equipment from excessive vibration or from detaching at the weld point during operation.*

 **NOTICE**

*When operating in rainy weather or in wet conditions, the Control Box and cables must be thoroughly dried **BEFORE** placing them in the Carrying Case at the end of the day.*

 **NOTICE**

*Keep the Carrying Case dry at all times. **DO NOT** allow moisture to get inside the case. Moisture trapped in the case can adversely affect components.*

Topcon cannot anticipate all possible circumstances that could result in a hazard. The warnings contained herein, therefore, are not all inclusive. If you use a tool, procedure, work or operating method other than those Topcon recommends, ensure the safety of yourself and those around you before continuing.



# Limited Warranty

## Electronic and Mechanical Components

TOPCON warrants that the electronic components manufactured by TOPCON shall be free of defects in materials and workmanship for a period of one year from the original date of shipment to the dealer. TOPCON warrants that all valves, hoses, cables and mechanical parts manufactured by TOPCON shall be free of defects in materials and workmanship for a period of 90 days from the date of installation.

## Return and Repair

During the respective warranty periods, any of the above items found defective may be shipped to TOPCON for repair. TOPCON will promptly repair the defective item at no charge, and ship it back to you. Calibration of components, labor and travel expenses incurred for in-field removal and replacement of components are not covered under this warranty policy. Damage to components due to negligence, abuse or improper use is NOT covered under this warranty.

## Warranty Disclaimer

The above warranties are in lieu of all other warranties, whether expressed or implied, including all warranties or merchantability, or fitness for a particular purpose. In no event will Topcon Laser Systems, Inc. or its Representative be liable for lost profits or other

consequential damages arising from the purchase or use of TOPCON's components or any performance hereunder or any claims of negligence, even if TOPCON has been advised of the possibility of such damages.

## **Service Information**

Service assistance can be provided by contacting your local TOPCON dealer or by calling the Corporate Service Center.

Phone: (800) 443-4567  
8 a.m. to 5 p.m. Pacific Time  
Monday through Friday

FAX: (925) 460-1329

Travel charges will be applied for any on-site service whether warranty or non-warranty in nature.

---

# Glossary

## A

### **Aggregate**

Various hard, inert materials such as sand, gravel, pebbles, etc. used as the bulk material in asphaltic mixes.

### **Angle of Attack**

The angle that exists between the bottom of the screed and the grade over which the screed is traveling.

### **Auger**

The broad, spiral flange on a screed which rotates and spreads paving material evenly in front of the screed.

### **Auger Shadows**

The dark and light areas along the length of a mat surface caused by the compaction of materials having different densities and textures.

### **Automatic Feed Controls**

The dual feed system on a paving machine used to maintain a constant head of material in front of the screed.

### **Automatic Grade and Slope Controls**

Sensing equipment used on paving machines to set and maintain proper elevations and percent slope. Paver Control System Five™ provides paver operators with automatic grade and slope control.

## **B**

### **Bitumen**

A thick, viscous, petroleum-based substance used as a bonding agent in asphaltic mixes.

### **Bail**

A wire frame added to the Tracker that acts as a fixed target to compensate for rapid air temperature changes.

## **C**

### **Calibration**

Setting the elevation reading or Slope Sensor reading to match the actual position of the screed.

### **Compaction**

To press tightly, thereby increasing the density of paving material.

### **Cone**

Pattern of distribution of the Sonic Tracker II™ sound waves. The sound waves leave the Tracker in a circular pattern that gets wider as it gets further from the Tracker.

### **Conveyor**

The assembly used to move paving material from the hopper to the auger.

### **Cross Slope**

The angle of slope required to produce a desired surface slope. Cross slope is measured in percent.

**Crown**

The transverse contour of a finished mat.

The contour of the screed plate.

The transition line between 2 different slopes (i.e. between lanes or between lanes and shoulders).

**Lead Crown**

The contour or profile from side to side of the leading edge of the screed.

**Negative Crown**

Contour which is higher at the edges than at the center of a mat.

**Positive Crown**

Contour which is higher at the center than at the edges of a mat.

**Tail (Road) Crown**

The contour of the trailing edge of the screed.

**Cut-off Shoe**

A detachable plate used to reduce the paving width of a screed.

**D****Density**

Compactness of paving material.

**E****Edger Plate**

A vertical plate at each end of the screed used to confine the head of material.

## **Elevation**

The vertical height or depth of the surface being laid. Elevation is measured in centimeters, inches, or feet.

## **F**

### **Feeders**

The auger-conveyors on the right and left hand sides of a paving machine.

## **G**

### **Grade**

The base surface (road bed) over which paving is being laid.

The elevation of a fresh mat in relation to the base.

The incline of a paving surface in the direction of travel, expressed by stating the rise or fall as a percent age of horizontal distance.

(i.e., 6% grade = 6' of elevation change in 100' of horizontal longitudinal run).

### **Grade Control**

A means of controlling the elevation of a mat as it is being laid.

### **Grade Sensor**

An electric device which detects positive and negative changes in elevation from a grade reference (i.e., surface string, floating beam, mat reference, adjacent mat or curb surface).

## **H**

### **Head of Material**

The volume of paving material directly in front of and across the entire length of the screed.

### **Hopper**

The area at the front of the paving machine which receives the paving material.



**Hydraulic**

Liquid in motion under pressure, the flow of which causes work to be accomplished.

**Hydrostatic Transmission**

Power transmitted by a positive displacement pump through a liquid under pressure to a positive displacement motor.

**I****Inclinometer**

See Slope Sensor

**J****Joint Matcher**

See Automatic Level Control

**L****LCD**

Liquid crystal display. LCD is used in the display window on the Control Box and Sonic Tracker II™ to show numbers and symbols for Paver Control System Five™ functions.

**LED**

Light Emitting Diode. These are the red lights seen on the faces of the Control Box, Sonic Tracker II™ and Laser Tracker.

**Line of Shear**

The lateral line of contact in the paving material at the leading edge of the screed pre-strike-off where material divides to pass beneath the screed plate or moves upward along the face of the screed into the augured material for later placement.

**M****Mat**

The material being placed by a paver/finisher.

## **N**

### **Null**

A condition which exists when components are at rest.

### **“Null” Screed**

A screed resting flat on the mat and having no angle of attack.

## **O**

### **On Grade**

When a surface is at the desired elevation or slope, it is referred to as being on grade.

### **Overlay**

Paving over an existing mat.

## **P**

### **Paddle Box**

The sensing device used with automatic feed control to measure and control the head of material.

### **Percent (%) Slope**

The unit of measure used for cross slope.

### **Pull Points**

See Tow Points

### **Push Roller**

Rollers mounted at the front of the paver to control the contact area between the paver and the asphalt truck tires.

## **Q**

### **Quarter Points**

Points on the screed midway between the center and the ends.

## R

### Ripples

Short frequent changes in the elevation of a mat surface.

## S

### Screed

The assembly behind the tractor. The screed strikes off, smooths and compacts the paving material into a semi-finished mat.

### Screed Extensions

Attachments for increasing screed width.

### Screed Heaters (Burners)

Devices which preheat the screed plate to a temperature approximately that of the material to be laid.

### Screed Plate

The bottom plate of the screed.

### Slope

The incline of a paving surface perpendicular to the direction of travel expressed by stating the rise or fall of a percentage of horizontal distance (i.e. 2% slope = 2" of elevation change in 100" of lateral run).

### Slope Control

A means for controlling the transverse elevation of the fresh laid mat in relation to the grade.

### Slope Sensor

An electrical device which detects positive and negative change in lateral elevation using the grade controlled side of the machine as a reference.

## **Survey**

Function used to show the current elevation when in CAL mode. Also used in Laser Tracker operations in conjunction with the Enter Button to move the Tracker receiver up and down.

## **T**

### **Thickness Control Screws**

The adjusting crank located at the rear of each side arm, used to control the angle of attack of the screed.

### **Tow Points (Pull Points)**

The points where the side arms of the screed are attached to the Tractor unit.

### **Transverse Beam**

A steel bar connected to the side arms of a screed for mounting the Slope Sensor.

### **Temperature Bail™**

A wire frame added to the Tracker that acts as a fixed target to compensate for rapid air temperature changes.

## **V**

### **Vibrators**

A rotating shaft and eccentric weight assembly mounted on the screed that produces vibration.

## **W**

### **Wave**

Long repeating changes in the elevation of the mat surface.

### **Working Window**

Adjustable region of measurement used by the Sonic Tracker II™ to determine if elevation correction is required.

# Index

## A

Air temperature  
compensating for **1-4, 2-22, 6-1, 6-6**

Arrows

and Cross Communication **4-9**  
and Set Mode **4-7**  
and Valve Offset **4-24, 4-25**  
grade adjustment **4-5**  
grade correction w/ Tracker **2-19, 2-20**

Auto/manual button **4-13**

*See also* Automatic mode

*See also* Manual mode

Automatic mode **4-13**

and beeper **4-31**  
and paving **5-8, 5-13, 7-2, 7-3**  
auto/manual button **4-13**

Averaging **4-26**

## B

Bail **1-4, 2-23**

*See also* Air temperature

*See also* Temperature bail

Base quality **2-13**

controlling mat **2-14**  
rolling techniques **2-14**

Beeper alarm **4-31**

## C

Checking grade **3-12–3-13**

Checking mat depth **2-4, 5-9, 7-2**

Components **1-2, 1-3**

control box **1-3**  
laser tracker **1-7**  
slope sensor **1-5**  
Smoothtrac SAS **1-6**  
Sonic Tracker II **1-4**  
trackerjack **1-7**

Control box **1-3, 4-2**

and moisture **1-8**  
auto mode **4-13**  
cables **5-2**  
cleaning **1-8**  
correction indications **2-19, 2-20**  
cross slope setup **5-11–5-14**  
elevation setup **5-7–5-10**  
Grade Adjustment Knob **4-4**  
grade correction **1-3**  
manual mode **4-13**  
memory **4-16**  
menus **4-16**  
mounting **4-14**  
operation **4-2–4-14**  
power on/off **4-3**  
settings **4-16**  
slope correction **1-3**

Control mode LED **4-6**

Cross communication **4-8–4-10**

Cross slope setup **5-11–5-14**

Curb, tracking **6-5**

Cut/fill lath **3-7**

## D

- Deadband elevation **4-27**
- Deadband slope **4-29**
- Default settings **4-16**

## E

- Elevated stringline  
and grade stakes **3-9**  
setting **3-5–3-9**
- Elevation  
*See* Screed elevation
- Elevation mode **4-11**  
LED **4-11**
- Elevation reference  
set in control box **4-7**
- Elevation setup **5-7–5-10**

## F

- Factory settings **4-16**

## G

- Gain  
elevation **4-20**  
slope control **4-21**
- Grade Adjustment Knob **4-4**
- Grade check **3-12–3-13**
- Grade checking lath **3-12**
- Gutter, tracking **6-5**

## H

- Head of material, force M **2-5, 2-7**

## I

- Indicate button **4-12**
- Indicate mode **4-12**  
*See also* Manual mode

## J

- Jog button  
lower **4-14**  
lower cylinder **4-14**  
maximize travel **5-3**  
raise **4-14**  
raise cylinder **4-14**
- Joint match **3-2, 6-5**

## L

- Laser control  
above grade **2-24**  
below grade **2-25**  
on-grade **2-24**  
receiver **2-24**  
transmitter **2-24**
- Laser tracker **1-7**
- L-bar **6-3–6-5**  
and SAS **6-14**  
and screed extension **6-4**  
mounting on tow arm **6-14**  
position **6-3**  
tracking with **6-3**  
using w/ ski **6-14**
- LED **4-16**  
auto mode **4-13**  
control box menus **4-16**  
display **4-3**  
for bail **2-23**  
function indicators **4-6**  
grade adjustment **4-5**  
indications **4-5**  
light sensor **4-2**
- Lower cylinder w/ jog button **4-14**

## M

- Manual mode **4-13**  
and jog button **4-14**  
and paving **7-7–7-8**  
auto/manual button **4-13**

changing mat depth **5-9**  
control **4-14**  
Mat depth **2-4, 5-9, 7-2**  
Menu settings  
default **4-16**  
select **4-14**  
Mix characteristics **2-9**  
gradation **2-9**  
segregation **2-10**  
temperature **2-11**

**O**

On-grade **2-18, 4-12**

**P**

Paver machine  
and truck exchange **2-6**  
components **2-1**  
forces **2-5-2-12**  
setup **5-2**

Performance menu  
accessing **4-16-4-19**  
auto/manual button **4-13**  
averaging **4-26**  
beeper alarm **4-31**  
deadband elevation **4-27**  
deadband slope **4-29**  
gain (elevation) **4-20**  
gain (slope control) **4-21**  
make selections **4-14**  
settings **4-16-4-35**  
test **4-34**  
unit (measurement) **4-32**  
valve offset **4-23**

Planing angle **2-2**  
Projected slope stringline **3-10-3-11**

## **R**

Raise cylinder w/ jog button **4-14**  
Reaction of material, force R **2-5, 2-9**  
Reference  
*See* Elevation reference

## **S**

SAS **1-6**  
paver placement **6-19-6-20**  
placement **6-13**  
positioning **6-16-6-19**  
setup **5-6-5-7, 6-13-6-15**

Screed  
and angle of attack **2-2**  
operation **2-2-2-5**  
Sonic Tracker II **6-8**

Screed elevation  
measuring w/ laser tracker **1-7**  
measuring w/ Smoothtrac SAS  
**1-6**  
measuring w/ Sonic Tracker **1-4**

Screed tilt  
measuring w/ slope sensor **1-5**

Slope  
control **2-26-2-27**  
measuring **1-5**

Slope mode **4-11**  
LED **4-11**

Slope sensor **1-5, 2-26**

Smoothtrac **1-6**  
*See also* SAS

Sonic averaging system  
*See* SAS

Sonic Tracker II **2-15-2-17**  
above grade **2-19**  
and mat elevation **6-7**  
and screed pivot point **6-9**  
bail **2-22**  
below grade **2-20**  
correct placement **6-8, 6-12**  
footprint **2-17**

incorrect placement **6-9**  
mechanical ski **6-6**  
obstructed **2-21**  
off reference **2-20**  
on-grade **2-18**  
operation **2-15**  
recommended height **6-2**  
screed **6-8**  
setup **2-17, 5-4–5-5**  
temperature changes **2-22**  
temperature conditions **6-6**  
working window **2-16, 2-17**

Stringline **6-6**  
and grade stakes **3-9**  
and Tracker **6-7, 6-8**  
elevated **3-5, 6-7**  
projected slope **3-10**  
surface **3-2, 6-8**

Surface stringline **3-2**  
setup **3-4–3-5**

Survey  
button **4-12**  
on-grade **4-12, 5-4, 5-6, 5-7**

Survey mode  
LED **4-6**

System **1-3–1-5**  
*See also* Components

## **T**

Temperature bail **2-22, 2-23, 6-1, 6-6**  
attach **5-4, 6-15**  
LED **2-23**

Temperature changes **2-22**

Test valves **4-34**

Tow point **2-2**  
force P **2-5**  
truck exchange **2-6**

Tow point path **2-2**

Trackerjack **1-7**

Tracking  
curb **6-5**  
gutter **6-5**  
joint matching **6-5**  
sub-grade **6-5**

## **U**

Unit, setting **4-32**

## **V**

Valve offset **4-23**

## **W**

Weight of screed, force W **2-5, 2-12**  
Working window **2-16, 2-17**



# Notes:

---

---

---

---

---

---

---

---

---

---

---

---

---

---

---

---

---

---

---

---

---

---

---

---

**Notes**







TOPCON

 **TOPCON**

**Topcon Positioning Systems, Inc.**

5758 W. Las Positas Blvd.  
Pleasanton, California U.S.A.  
Phone: 925 • 460 • 1300  
Fax: 925 • 460 • 1315

©2004 Topcon Corporation All rights reserved  
No unauthorized duplication

P/N: 7010-0341 Rev. F Printed in U.S.A. 04/04 450

*Sonic T*