

Milling 2D

The industry-standard for elevation and slope control for asphalt milling patented Sonic Averaging System (SAS) provides smoother results allow for any chosen mill depth durable components, time-tested system delivers ultimate reliability.

Features & Benefits:

- The industry-standard for asphalt milling
- Track existing surface or string line
- Adjustable Mill depths
- Durable, time-tested components
- Plug and Play components

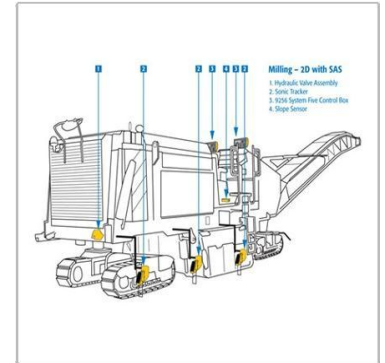

Sonic Tracker®

- Reference: elevated stringline, surface string, poured curbs, or an existing surfaces
- Rugged Cast Housing With Completely Sealed internal electronics
- Easy To Attach and position over
- Reference Bright grade indication LED's



9256 Control Box

- Large, backlit grade LCD
- Bright, multi-color LEDs display continuous grade information
- Simple push button switches and grade knob operation
- Convenient, out-of-the-way mounting

Sonic Averaging System (SAS)

- Industry's first choice as a non-contacting system
- Continuously measure the elevation over the surface
- Automatically averages and adjusts tow point cylinder. The SAS is convenient, maneuverable and produces a great finished surface.

